

**LEISTER**®

English

**TWINNY T7**



**TWINNY T5**



**Leister Technologies AG**

Galileo-Strasse 10

6056 Kaegiswil

Switzerland

+41 41 662 74 74

leister@leister.com

leister.com

# Contents

<b>1. Application</b>	<b>4</b>
1.1 Intended use	4
1.2 Intended use	5
1.3 Non-intended use	5
<b>2. Technical data</b>	<b>5</b>
<b>3. Transport</b>	<b>6</b>
<b>4. Your TWINNY T7/T5</b>	<b>6</b>
4.1 Type plate and identification	6
4.2 Scope of delivery (standard equipment in the case)	6
4.3 Optional accessories	6
4.4 Overview of device parts	7
4.5 Power supply interruption	8
<b>5. TWINNY T7 control panel</b>	<b>8</b>
5.1 Overview of the TWINNY T7 control panel	8
5.2 Function keys	9
5.3 Status LED display	9
5.4 Display symbols of the status display	10
5.5 Display symbols of the function display	10
5.6 Display symbols of the working display	11
<b>6. Setup menu on the TWINNY T7 control panel</b>	<b>12</b>
6.1 Menu navigation overview	12
6.2 Setting up, saving, and selecting recipes (Save Recipes)	13
6.3 Entering recipe names	14
6.4 Standby	15
6.5 Basic setting and Advanced Mode	15
6.6 Duty Info	15
6.7 Duty Info	16
6.8 Warnings	16
6.9 Machine Setup	16
6.10 Showing current values (Application Mode)	16
6.11 Set Values	17
6.12 Reset to defaults	17
6.13 Day distance display	17
6.14 Key lock	18
<b>7. Commissioning the TWINNY T7</b>	<b>19</b>
7.1 Work environment and safety	19
7.2 Setting the welding parameters	19
7.3 Preparation for welding	21
7.4 Welding sequence	21
7.5 Switching off the device	23

<b>8. Warnings and error messages (TWINNY T7)</b>	<b>24</b>
<b>9. TWINNY T5 control panel</b>	<b>25</b>
9.1 Symbols	25
9.2 Status LED display	26
9.3 Setting the parameter units	26
9.4 Key lock	26
<b>10. Commissioning the TWINNY T5</b>	<b>27</b>
10.1 Work environment and safety	27
10.2 Setting the welding parameters	27
10.3 Preparation for welding	29
10.4 Welding sequence	29
10.5 Switching off the device	30
<b>11. Error messages</b>	<b>30</b>
<b>12. Settings on the TWINNY T7/T5</b>	<b>31</b>
12.1 Replacement of pressure rollers	31
12.2 Replacing the welding nozzle	32
12.3 Assembling the field kit	32
12.4 Assembling the guide bar	34
<b>13. Disposal</b>	<b>35</b>
<b>14. Declaration of conformity</b>	<b>36</b>

## **Congratulations on your purchase of the TWINNY T7/T5.**

You have chosen a first-class hot-air welder.

It was developed and produced in accordance with the very latest state of technology in the plastics-processing industry. It has also been manufactured using high-quality materials.



We recommend that you always keep the operating instructions with the device.

## **TWINNY T7/T5 automatic welder**



You can find more information on the TWINNY and the myLeister app at [leister.com](http://leister.com).

### **1. Application**

#### **1.1 Intended use**

**Read through the operating instructions before commissioning for the first time.**

In addition to the safety instructions contained in the individual sections of this instruction manual, the following regulations must always be observed.

#### **Warning**



##### **Danger to life**

There is a danger to life from electric shock due to electrical voltage. The welding machine must therefore only be connected to sockets and extension cables with a protective earth conductor.

Protect the welding machine from moisture and wet conditions. Prior to commissioning, check the power cord, the plug, and the extension cable for electrical and mechanical damage. The welding machine may only be opened by instructed, qualified personnel.



##### **Danger of fire and explosion**

The welding machine can become an ignition source for fire and explosion. It must therefore not be used near explosive gases or flammable materials. To avoid burning of the material to be welded, please read the material safety data sheet from the material manufacturer. The welding machine must only be used in the open or in a well-ventilated area.



##### **Risk of burning**

Do not touch the heating element tube and nozzle when they are hot. The device should always first be allowed to cool down.

Never point the hot air flow at people or animals.

#### **Caution**



The nominal voltage specified on the device must match the local line voltage. If the line voltage fails, switch off the main switch and swivel the hot-air blower into the park position.



If the device is being used on construction sites, a fault current circuit breaker **must be used to protect site personnel**.



##### **Do not touch moving parts.**

There is a risk of inadvertently becoming caught and being pulled in. Do not wear loose articles of clothing such as scarves or shawls. Tie up long hair or protect it by wearing headgear.



The device **may only be operated under supervision** as waste heat can reach flammable materials. The device should only be operated by **trained specialists** or under their supervision. Children are not permitted to operate the device.



When welding, be aware of hazards in the surrounding area, e.g., risk of tripping, risk of slipping, strong sunlight, unattended equipment, etc.

## 1.2 Intended use

TWINNY T7/T5 is intended for lap welding and the assembly of films and sealing sheets. The maximum overlap width is 125 mm. The maximum welding seam width is 50 mm.

Only use original Leister spare parts and accessories; otherwise, any warranty or guarantee claims will be invalidated.

## Material types and thicknesses

Material	Material types and thicknesses
PE-HD, PP	0.3 mm – 2.5 mm
PVC-P, PE-LD, TPO, FPO	0.3 mm – 3.0 mm

Additional materials upon request.

## 1.3 Non-intended use

Any other use or any use beyond the type of use described is deemed non-intended use.

## 2. Technical data

		TWINNY T7	TWINNY T5	TWINNY T5
	* V~	230	230	120
	W	3450	3450	1800
	Hz		50/60	
	°C		100 – 560	
	°F		212 – 1040	
	%		45 - 100	
	m/min		0.8 – 8	
	ft/min		2.6 – 26.2	
	N/lbf		1000 / 225	
	LpA (dB)		73 (K = 3 dB)	
	Kg lbs	10.5 / 23.1		9.5 / 21
	mm		350 × 360 × 260	
	inch		13.8 × 14.2 × 10.2	

\* Connection voltage cannot be switched  
Subject to change without prior notice.

### 3. Transport

When transporting the hot air welding machine, use only the transport box included in the scope of delivery (as well as the handle attached to the transport box).



The **hot-air blower (19)** must be allowed to cool down sufficiently prior to transport (see Cool down mode).



Never store flammable materials (such as plastic or wood) in the transport box.



Never use the **carrying handles (2)** on the device or on the transport box for transporting with a crane.



**Two persons are required** for transporting the machine with the transport box.

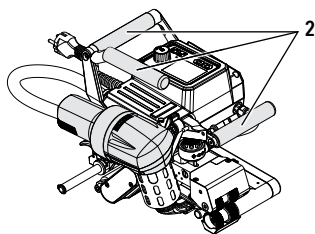

To lift up the hot-air welder by hand, use the **carrying handles (2)**.

### 4. Your TWINNY T7/T5

#### 4.1 Type plate and identification

The model and serial number are indicated on your device's **type plate (21)**. Please transfer this information to your operating instructions. In the event of any inquiries to our representatives or authorized Leister Service Centers, please always refer to this information.

Model: .....

Serial no.: .....

Example:



#### 4.2 Scope of delivery (standard equipment in the case)

1 × TWINNY T7/T5 device (as per configuration)

- 1 × wire brush
- 1 × Safety instructions
- 1 × Quick guide

#### 4.3 Optional accessories

- Field kit
- Guide bar
- Various drive/pressure rollers
- Various welding nozzles

#### 4.4 Overview of device parts

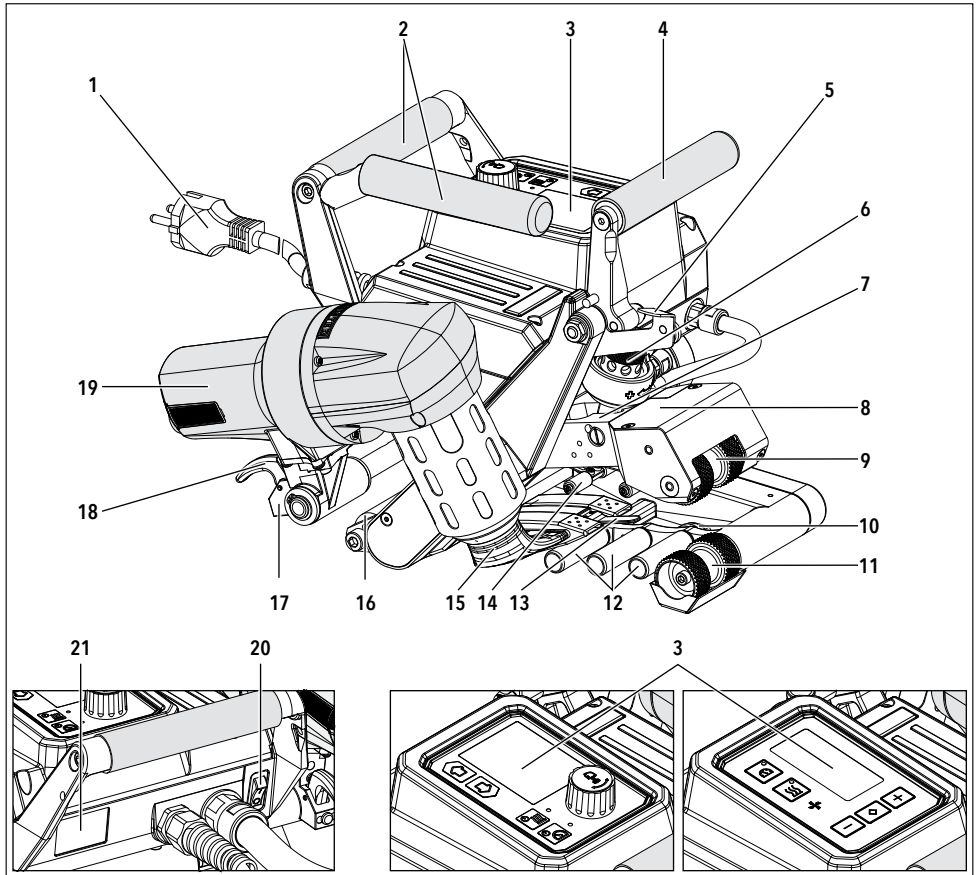

1. Power cord
2. Handles
3. Control panel
4. Clamping lever
5. Clamping lever lock
6. Welding force module
7. Clamping arm
8. Swivel head
9. Drive/pressure rollers, upper
10. Track roller, rear
11. Drive/pressure rollers, lower

12. Contacting system, lower
13. Towing bar
14. Contacting system, upper
15. Welding nozzle
16. Track roller, front
17. Swivel-in mechanics
18. Hot-air blower lock
19. Hot-air blower
20. Main switch
21. Type plate

## 4.5 Power supply interruption



The nominal voltage specified on the device must match the local line voltage.  
If the line voltage fails, switch off the main switch and swivel the hot-air blower into the park position.

The hot-air blower (19) must be allowed to cool down sufficiently prior to transport (see Cool down mode).

Condition of device prior to power supply interruption	Duration of power supply interruption	Duration of power supply interruption	
		TWINNY T7	TWINNY T5
Drive and heating are switched on (welding process).	≤ 5 Sek.	The device continues running without a restart safeguard with the same settings as before the interruption.	
Drive and heating are switched on (welding process).	> 5 Sek.	The device starts up and the start display appears on the display.	
The device is not welding.	-	The device starts up and the start display appears on the display.	



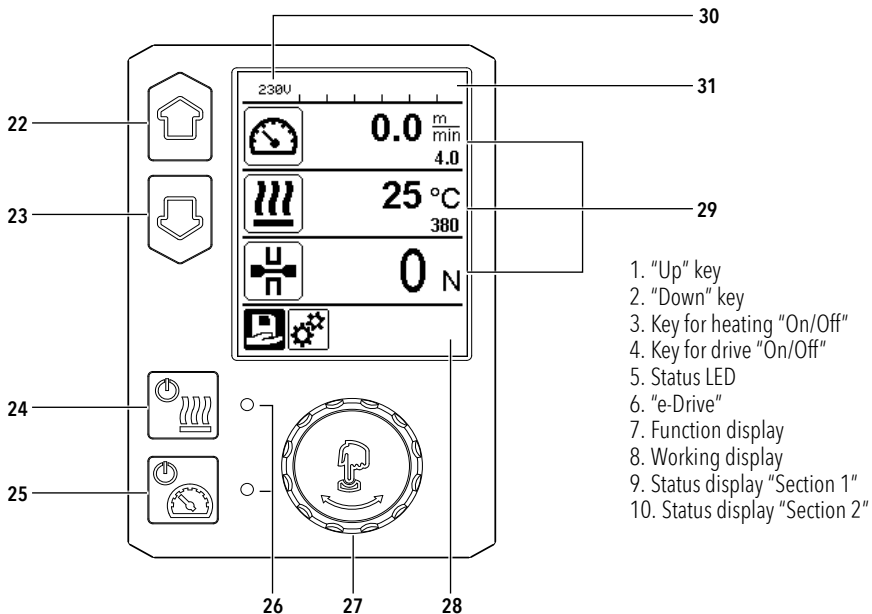

## 5. TWINNY T7 control panel

### 5.1 Overview of the TWINNY T7 control panel



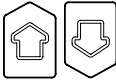

## 5.2 Function keys

Keyboard mode		Current selection Working display	Current selection function display	Current selection Setup menu
	<b>Up (22) Down (23)</b>	Changes the position within the working display	Switches from function display to working display	Changes the position within the Setup menu
	<b>Heating On/Off (24)</b>	Switches heating on/off	Switches heating on/off	No function
	<b>Drive On/Off (25)</b>	Switches drive on/off	Switches drive on/off	No function
	<b>Press "e-Drive" (27)</b>	Set value is adopted straight away and the selection jumps straight back to the function display	Selected function is executed	Selection of the marked position
	<b>Rotate "e-Drive" (27)</b>	Setting the desired setpoints in 10 °C or 0.1 m/min increments	Changing the position in the function display	<ul style="list-style-type: none"> <li>• Changes the position within the Setup menu</li> <li>• Setting the value of the selected position</li> </ul>

## 5.3 Status LED display

### Heating

The LED on the **Heating «On/Off» key (24)** displays the respective condition of the heating.

LED status (26) Heating On/Off (24)	Condition	Cause
LED off	Heating is switched off	
LED flashes green	Heating is switched on. Temperature is outside the tolerance range	
LED continuously green	Heating is switched on. Temperature is within the tolerance range	
If, during heating operation, a warning message occurs in the <b>status display "Section 2" (31)</b> or if there is an error message in the <b>working display (29)</b> , then this will be displayed as follows:		
LED flashes red	Warning message for the heating	See warning and error message
LED continuously red	Error message for the heating	See warning and error message

## Drive

The LED on the **Drive «On/Off» key (25)** displays the condition of the drive.

LED status (26) Drive On/Off (25)	Condition	Cause
LED off	Drive is switched off	
LED continuously green	Drive is switched on	
If, during operation of the drive, a warning message occurs in the <b>status display "Section 2" (31)</b> or if there is an error message in the <b>working display (29)</b> , then this will be displayed as follows:		
LED flashes red	Drive current limiting is active	See warning and error message
LED continuously red	The drive has an error	See warning and error message

## 5.4 Display symbols of the status display

### Status display «Section 1» (30)

Name of the saved value	Description
<b>230 V</b>	Line voltage currently present on the power plug
<b>001</b>	Current file number of the welding data record

### Status display «Section 2» (31)



#### Warning present

(see Chap. Warnings & error messages)



#### Undervoltage



#### Overvoltage



#### Key lock

(only with active key lock)



#### Heating













(only with activated heating)

## 5.5 Display symbols of the function display

Available menus are selected with the **«e-Drive» (27)** of the **control panel (3)**.

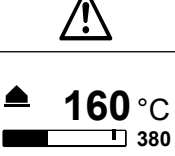
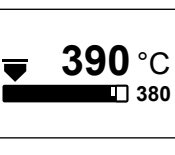
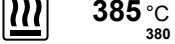
Symbol	Meaning	Symbol	Meaning
	Select freely definable and predefined recipes		Service menu (can only be accessed by entering the password)
	Settings		Save
	Return to working display (exits a menu directly)		Delete the selected item
	Go back one level		Edit the selected item
	Reset settings or hour counter		

## 5.6 Display symbols of the working display

Symbol	Meaning
	Drive speed [m/min / ft./min]
	Drive speed blocked [m/min / ft./min]
	Air temperature [°C/°F]
	Welding force [N/lbf]
	Air volume [%]
	Information box
	Devices in standby mode. The heating is switched off after the counter runs through.
	An error has occurred. An error code also appears (the device is no longer ready for use). Contact an authorized Service Center. See Chapter Warnings and error messages
	<b>Warning:</b> See Chapter Warnings and error messages
	The arrow pointing upward and the progress bar indicate that the setpoint (shown on the progress bar) has not yet been reached (too cold). The flashing value is the actual value. The value next to the progress bar is the setpoint.
	The arrow pointing downward and the progress bar indicate that the setpoint (shown on the progress bar) has not yet been reached (too hot). The flashing value is the actual value. The value next to the progress bar is the setpoint.
	If Set Values is activated, both the actual temperature (large font size) and the set temperature (small font size) are displayed. Default setting ex-works.
	If Set Values is deactivated, then only the actual values (large) are displayed during operation, otherwise only the setpoint values (large).
	<b>Cool down mode</b>
	<b>Hardware error message</b> (heating element faulty). The device is no longer ready for operation. Contact an authorized Leister Service Center.

## 6. Setup menu on the TWINNY T7 control panel

### 6.1 Menu navigation overview

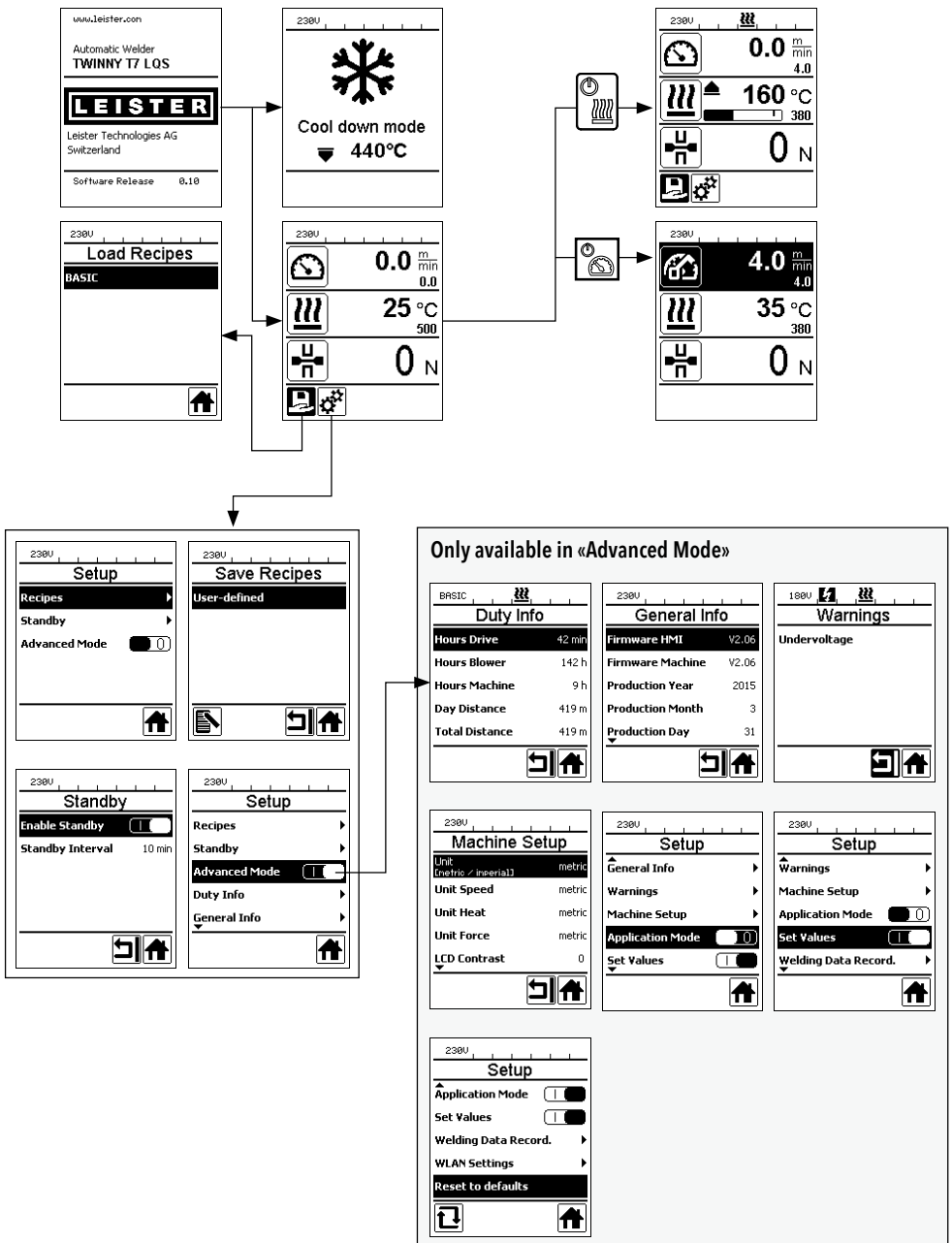

## 6.2 Setting up, saving, and selecting recipes (Save Recipes)

Your TWINNYT7 has nine freely definable recipes and the «BASIC» recipe. «Save Recipes» can be used to save the setpoint settings for the drive, air temperature, and air volume welding parameters under a freely selectable designation (see Entering recipe names).

### Creating a new recipe

1. Set up desired setpoints [Working display, "e-Drive" (27)]
2. Select and confirm the Setup menu [Menu selection, "e-Drive" (27)]
3. Select Save Recipes [Menu selection, "e-Drive" (27)]
4. Select and confirm the User-defined menu [Menu selection, "e-Drive" (27)]
5. Select and confirm the Edit selected item menu [Menu selection, "e-Drive" (27)]
6. Enter desired recipe name, select Enter on the keyboard (see Entering recipe names), and confirm [Menu selection, "e-Drive" (27)]
7. Select and confirm the Save menu [Menu selection, "e-Drive" (27)]

Your newly created recipe is now saved and can be accessed at any time under the name that has been entered.



### Adjusting an existing recipe

1. Set up desired setpoints [Working display, "e-Drive" (27)]
2. Select and confirm the Setup menu [Menu selection, "e-Drive" (27)]
3. Select Save Recipes [Menu selection, "e-Drive" (27)]
4. Select and confirm the recipe to be adjusted [Menu selection, "e-Drive" (27)]
5. Select and confirm either Save function, Edit selected item, or Delete [Menu selection, "e-Drive" (27)]
6. If the Edit selected item has been selected, enter a freely selectable recipe name in accordance with Steps 6 and 7 described above





## Selecting a recipe





- Choosing the "Select freely definable and predefined recipes" icon in the **function display (28)** takes you to the "Select Recipes" menu.
- Use the "**Up**" and "**Down**" (22/23) keys to position the cursor on the desired recipe and press "**e-Drive**" (27) to confirm.
- If, during operation, you change setpoints in recipes you have created, the setpoints will not be saved in the recipe. When the device is restarted, the values saved in the recipe will be displayed again.
- If you wish to apply the most recently used setpoints when you restart the device, you have to select the preprogrammed "BASIC" recipe.
- The currently selected recipe is displayed in the status display "**Section 1**" (30). An exception to this is the "BASIC" recipe; if this is selected, only the line voltage is displayed in the **status display (30)**.

## 6.3 Entering recipe names

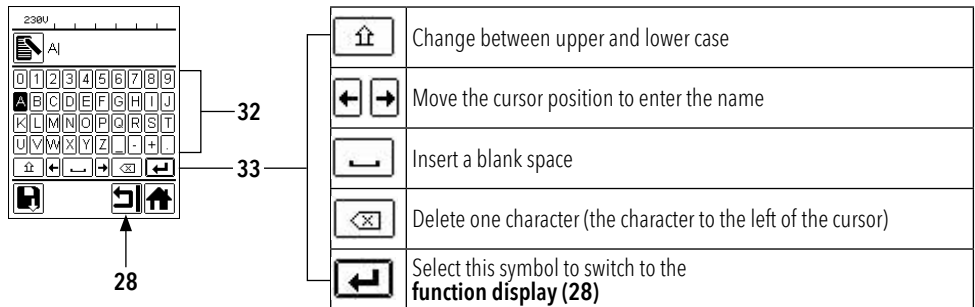
In keyboard mode, you can define names with a maximum of 12 characters.

Keyboard mode	Character selection (32)	Symbol selection (33)
 Up (22) Down (23)	Vertical character selection	
 Rotate "e-Drive" (27)	Horizontal character selection	Horizontal symbol selection
 Press "e-Drive" (27)	Confirm the selected characters	Confirm the selected symbols



	Change between upper and lower case
	Move the cursor position to enter the name
	Insert a blank space
	Delete one character (the character to the left of the cursor)
	Select this symbol to switch to the <b>function display (28)</b>

## 6.4 Standby

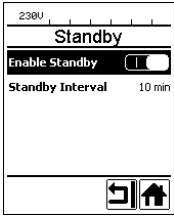

If the engine is switched off, the heating is activated, and if no key is activated during the time defined under Standby interval, then the device will switch over automatically to the Standby display. If the **"e-Drive" (27)** is not pressed during the subsequent 180 seconds, then the heating will automatically switch to Cool down mode. Standby will then appear on the display. Pressing **"e-Drive" (27)** causes the device to switch to Working mode.

Standby mode is not activated when the devices are shipped. The desired time interval can be defined individually by selecting the Standby menu with the **"e-Drive" (27)** and then setting the desired value with the **"e-Drive" (27)**.

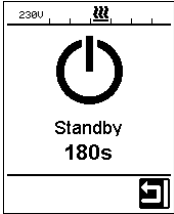

## 6.5 Basic setting and Advanced Mode

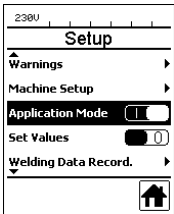

In the Basic setting, move through the Setup menu to save the profile, to Standby function, Application Mode, and Advanced Mode.

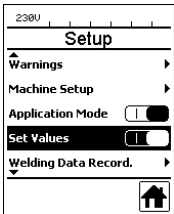

Additional information and setting options are available in Advanced Mode.

The functions listed in Chapters "Duty Info" to "Reset to defaults" are only available in Advanced Mode.

## 6.6 Duty Info

Under Duty Info you will find information regarding the runtime of your TWINNYT7.

Use the **"e-Drive" (27)** to access the Setup menu and confirm your selection. Now use the **"e-Drive" (27)** to set the Advanced Mode to On and then select Duty Info.



**Hours Drive:** Current runtime of the drive

**Hours Blower:** Current runtime of the blower

**Hours Machine:** Current runtime of the machine

**Day Distance:** Distance covered since last reset (must be reset manually)

**Total Distance:** Distance covered since commissioning of the device

## 6.7 Duty Info

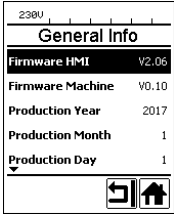

Under General Info you will find version information regarding the software in addition to information regarding the date of production.

Use the "**e-Drive**" (27) to access the Setup menu and confirm your selection. Use the "**e-Drive**" (27) to set the Advanced Mode to On and then select General Info.

## 6.8 Warnings

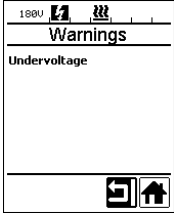

Warnings are displayed on a case-by-case basis in the **status display (31)**. If there is a warning pending, you can still continue to work largely without restrictions. The Warnings menu indicates the type of malfunction. Once the malfunction has been rectified, the entry disappears.

Use the "**e-Drive**" (27) to access the Setup menu and confirm your selection. Use the "**e-Drive**" (27) to set the Advanced Mode to On and then select Warnings.

## 6.9 Machine Setup

Use the "**e-Drive**" (27) to access the Setup menu and confirm your selection. Now use the "**e-Drive**" (27) to set the Advanced Mode to On and then select Machine Setup.

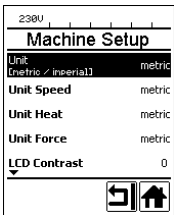

**Unit:** Setting the unit system (metric or imperial) for Unit Speed, Unit Heat, and Unit Force  
**Unit Speed:** Individually setting the unit used for speed (metric/imperial)  
**Unit Heat:** Individually setting the unit used for heat (metric/imperial)  
**Unit Force:** Individually setting the unit used for force (metric/imperial)  
**LCD Contrast:** Adjusting the LCD display contrast  
**LCD Backlight:** Adjusting the LCD display background illumination  
**Key Backlight:** Adjusting the keyboard background illumination for the **control panel (3)**

## 6.10 Showing current values (Application Mode)



If you wish to have an overview of relevant information, e.g., line voltage, capacity utilization of the heating, select the Setup menu and confirm your selection. Now activate the Application Mode.

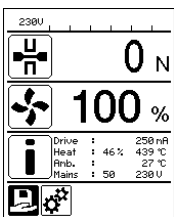

All available information (symbol **i**) is now displayed in the **working display (29)** (see Display symbols of the working display). The information field is always displayed below the field for the air volume.



## 6.11 Set Values

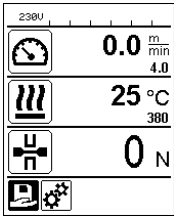

If you have activated the Set Values function, then the actual temperature (large) and the setpoint temperature (small) will be presented in the **working display (29)**. This will be in the analog form for the drive speed (m/min). If the function has been deactivated, only the setpoint values are displayed.

The actual value is always displayed for the Welding force parameter.

The Set Values function is activated ex-works.

## 6.12 Reset to defaults

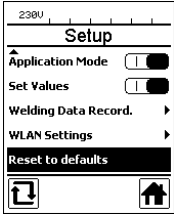

Use the **"e-Drive" (27)** to access the Setup menu and confirm your selection. Now set the Advanced Mode to On and then select Reset to defaults.

This function can be used to reset all of the individually set values back to the factory settings. The reset affects not only settings (Setup) but also recipes.

Confirm your selection with the key at the lower left (Reset to factory settings/Reset).

## 6.13 Day distance display

The welded distance is recorded as soon as the drive is running and more than 200 N force is displayed in the working display (29). The day distance can be called up as follows:

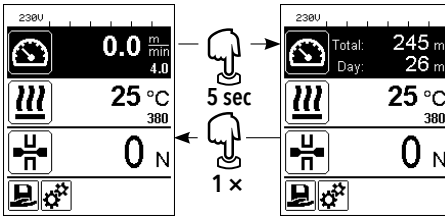

- Use the **"Up" (22)** and **"Down" (23)** arrow keys to position the cursor on the speed in the **working display (29)**.
- Hold the **"e-Drive" (27)** down for 5 seconds.
- The values of the day distance and the total distance are now shown in the speed display.
- Briefly pressing on the **"e-Drive" (27)** causes the speed to be shown again in the **working display (29)**.

## In welding operation

- The speed working display is blocked during welding.
- The speed setting is enabled by briefly pressing the **"e-Drive" (27)**.
- Hold the **"e-Drive" (27)** down for 5 seconds.
- The values of the day distance and the total distance are now shown in the speed display.
- Briefly pressing on the **"e-Drive" (27)** causes the speed to be shown again in the **working display (29)**.
- The speed function display is blocked again once you have left the day distance display.

## Resetting the day distance

The day distance can only be reset if the drive is switched off.

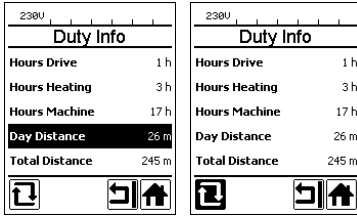

Duty Info	
Hours Drive	1 h
Hours Heating	3 h
Hours Machine	17 h
Day Distance	26 m
Total Distance	245 m

Duty Info	
Hours Drive	1 h
Hours Heating	3 h
Hours Machine	17 h
Day Distance	26 m
Total Distance	245 m

- Select the Day Distance row in the Duty Info menu (see Chapter Duty Info).
- The cursor will then automatically highlight the "Reset hour counter" icon. Use the **"e-Drive" (27)** to confirm.
- The hour counter is then reset.

## 6.14 Key lock

The TWINNYT7 has a key lock. This blocks the four keys and the **"e-Drive" (27)** on the **control panel (3)**. The key lock is activated or deactivated by simultaneously pressing the **"Up" and "Down" keys (22/23)** for at least 2 seconds. When the key lock is activated, this is indicated on the status bar.

## 7. Commissioning the TWINNY T7

Your TWINNY T7 has the Leister Quality System (LQS) and thus the function of welding data recording. Using the LQS and myLeister app, the TWINNY T7 records the drive speed, the temperature and the joining force during welding over the welding seam length at the specified distance interval. You can find more information in the corresponding operating instructions LQS/myLeister at leister.com.

### 7.1 Work environment and safety



#### Danger of fire and explosion

The welding machine can become an ignition source for fire and explosion. It must therefore not be used near explosive gases or flammable materials. To avoid burning of the material to be welded, please read the material safety data sheet from the material manufacturer. The welding machine must only be used in the open or in a well-ventilated area.



#### Risk of poisoning

When PVC is overheated, toxic hydrogen chloride vapors are produced. Therefore, work must always be carried out in a well-ventilated area. In addition, the specifications of the material manufacturer must always be observed and complied with when working with PVC.

### Power cord and extension cable

- The **power cord (1)** must be able to move freely and must not hinder the user or third parties during work (danger of tripping).
- The extension cables must be authorized for the utilization site (e.g., outdoors) and be marked accordingly. Take into account the necessary minimum cross-section for extension cables, as required.

230 V~	up to	50 m	<b>3 × 1,5 mm<sup>2</sup></b>
		up to	<b>100 m 3 × 2,5 mm<sup>2</sup></b>
120 V~	up to	50 m	<b>3 × 1,5 mm<sup>2</sup></b>
		up to	<b>100 m 3 × 2,5 mm<sup>2</sup></b>

### Power plants for energy supply

When using power plants as an energy supply, please ensure that the power plants are grounded and equipped with residual-current circuit breakers.

For the nominal output of the power plants, the formula  $2 \times$  nominal output of the hot-air welder applies.

### 7.2 Setting the welding parameters



Connect the device to a **socket with a protective conductor**. Any interruption of the protective conductor inside or outside of the device is not permitted. Only use extension cables with protective conductors.



The nominal voltage specified on the device must match the local line voltage. If the line voltage fails, switch off the main switch and swivel the hot-air blower into the park position.



If the device is being used on construction sites, a residual-current circuit breaker must be used to protect site personnel.

## Starting the device

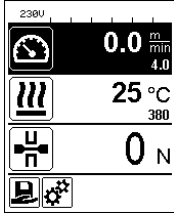

- Once you have prepared the work environment and the hot-air welder in accordance with the description, switch on the hot-air welder using the **main switch (20)**.
- After startup, the Start screen will appear briefly in the display with the version number of the current software release and the device designation.
- If the device was allowed to cool down beforehand, this will be followed by a static display of the setpoints of the most recently used recipe (the BASIC recipe is displayed when the device is commissioned for the first time).
- **The heating is not yet switched on at this stage.**



### CAUTION!

Exceeding the maximum welding force of 1000 N can cause mechanical damage to the device.



### Risk of crushing and shearing

Mechanically moving parts can cause hand injuries. Only hold the automatic hot-air welding machine by the handles provided for this purpose.

## Adjusting the welding force

- Unlock the **adjustment ring lock (34)** on the **welding force module (6)** and rotate the **adjustment ring (35)** on the **welding force module (6)** until the **clamping arm (7)** opens fully.
- Place two **test strips (36)** of the material to be welded on top of each other between the upper and lower **drive/pressure rollers (9/11)** and close the **clamping lever (4)**.
- Rotate the **adjustment ring (35)** of the **welding force module (6)** until the upper and lower **drive/pressure rollers (9/11)** lightly clamp the **test strips (36)**.
- Unlock the **clamping lever lock (5)** and open the **clamping lever (4)**.
- Rotate the **adjustment ring (35)** while the **welding force module (6)** is open until the welding force shown on the display matches the desired welding force with the **clamping arm (4)** closed and the **test strips (36)** inserted. To do this, the clamping lever must be opened and closed repeatedly.
- Lock the **adjustment ring lock (34)** on the **welding force module (6)** so that the welding force cannot be adjusted unintentionally.

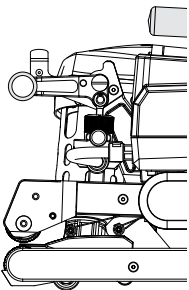

Clamping lever (4) closed

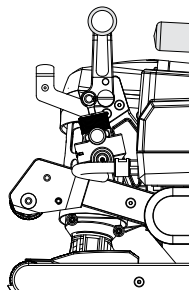

Clamping lever (4) open

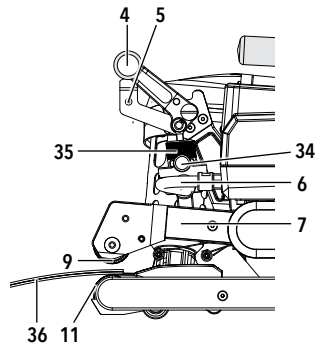

## Setting the speed, temperature, and air volume before welding

- If the drive is switched off, then the welding parameters for temperature, air volume, and speed are set as follows in the **working display (29)**:
- Using the **"Up" (22)** and **"Down" (23) arrow keys**, you can set the cursor to the desired **working display (29)**.
- Rotate the **"e-Drive" (27)** to set the setpoint. The set value is applied immediately.
- A switch is made to the function display after 5 seconds or by pressing the **"e-Drive" (27)**.

## Setting the speed, temperature, and air volume during welding

- If the drive is switched on, then the welding parameters for temperature, air volume, and speed are set as follows in the **working display (29)**:
- During welding, the speed working display is blocked and the cursor is positioned in the drive speed field.
- Briefly pressing the **"e-Drive" (27)** enables the speed setting and you can adjust the setpoint speed by rotating the **"e-Drive" (27)**.
- The block becomes active again after 5 seconds or when you press the **"e-Drive" (27)**.
- Using the **"Up" (22)** and **"Down" (23) arrow keys**, you can set the cursor to the heating or air working display. Rotate the **"e-Drive" (27)** to adjust the setpoint of the selected parameter. The set value is applied immediately.



Speed unblocked



Speed blocked

### 7.3 Preparation for welding

- The maximum overlap width is 125 mm.
- The sealing sheets must be clean and dry between the overlaps and on the upper and lower side.

### 7.4 Welding sequence



- **Caution:** Before the automatic welder is used, test welds are to be carried out in accordance with the welding instructions of the material manufacturer and with national standards or guidelines. The test welds must be checked.
- **Caution:** If the heating is switched on but the device is not welding or if the device is in Cool down mode, the **hot-air blower (19)** must be in the park position. Otherwise, the device may become damaged.
- **Caution:** Changing the position of the hot-air blower also changes the center of gravity of the device. Take this into account when lifting the device.
- **Caution:** When the hot-air blower is in the welding position, the guide rod extends beyond the device. Take this into account when handling the device.

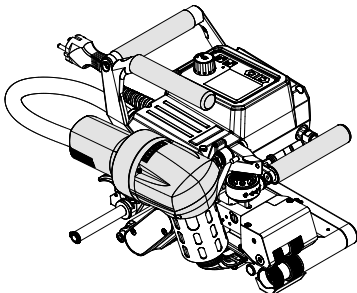

**Hot-air blower (19)** in welding position

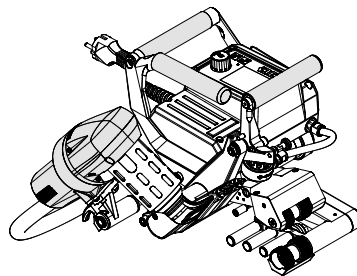

**Hot-air blower (19)** in park position

## Commencing welding



### Moving parts must not be touched.

There is a risk of inadvertently becoming caught and being pulled in. Do not wear articles of clothing such as scarves or shawls. Tie up long hair or protect it by wearing headgear.



### Risk of burning

Do not touch heating element tube and nozzle when they are hot. The device should always be allowed to cool down first. Do not point the hot air flow at people or animals.

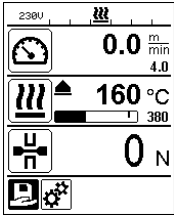

- Once you have set all welding parameters in line with your requirements, start the heating and the drive.
- Use the **Heating On/Off (24)** key to start the heating and the **Drive On/Off (25)** to start the drive. The **Heating On/Off (24)** key must be held down for 2 seconds.
- As soon as the heating has been switched on, an acoustic signal sounds, the status LED lights up, and "Heating on" appears briefly on the display. You will see a dynamic display of the current air temperature with a progress bar (setpoint and actual value) on the display.
- Make sure that the welding temperature has been reached before commencing work (heating-up time is 3 – 5 minutes).
- Insert the hot-air welder into the overlapping plastic sheets.
- Pull the lever for the **hot-air blower lock (18)**, lower the **hot-air blower (19)**, and guide the **welding nozzle (15)** between the overlapping sheets up to the stop. Make sure that the lever for the **hot-air blower lock (18)** engages in the welding position.
- Close the **clamping lever (4)** so that the **clamping lever lock (5)** engages.
- In the **status line (30/31)**, the file number is displayed alternately in the line voltage display.

## During welding

- During the welding process, the hot-air welder can be guided along the overlap using the **handles (2)**, the **clamping lever (4)**, or the optional guide bar.
- The welding speed, air volume, and air temperature can be adjusted at any time during welding (see Chapter Setting the speed, temperature, and air volume during welding).

## Finishing welding

- Unlock the **clamping lever lock (5)** and open the **clamping lever (4)** shortly before the end of the welding seam. The **upper drive/pressure roller (9)** and the **lower drive/pressure roller (11)** must never run in contact with one another.
- Next, pull the lever for the **hot-air blower lock (18)**, guide the **welding nozzle (15)** away from the overlap, and swivel the **hot-air blower (19)** into the park position.
- Make sure that the lever for the **hot-air blower lock (18)** engages in the park position.

**Caution:** If the heating is switched on but the device is not welding or if the device is in Cool down mode, the **hot-air blower (19)** must be in the park position. Otherwise, the device may become damaged.

## 7.5 Switching off the device

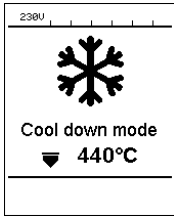

- Switch the drive and heating off using the **Drive On/Off (25)** and **Heating On/Off (24)** keys. The **Heating On/Off (24)** key must be held down for 2 seconds.
- The "Heating off" display appears and the device switches to Cool down mode (see Cool down mode).
- The blower switches off automatically after approx. 6 minutes.
- Now switch off the device with the **main switch (20)** and disconnect the **power cord (1)** from the electrical network.





- Wait until the device has cooled down.
- Check the **power cord (1)** and plug for electrical and/or mechanical damage.
- Use a wire brush to clean the **welding nozzle (15)** and **drive/pressure rollers (9/11)**.

## 8. Warnings and error messages (TWINNY T7)

Warning and error messages are displayed on a case-by-case basis in the **status display (31)** or in the **working display (29)**. If there is a warning pending, you can still continue to work largely without restrictions.

**If an error message appears, however, you cannot continue working.** The heating is switched off automatically, the blower is switched on, and the drive is blocked. The display of the corresponding error codes proceeds without delay in the **working display (29)**.

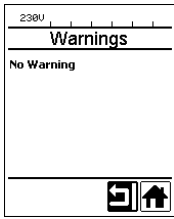
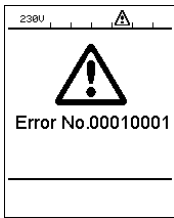
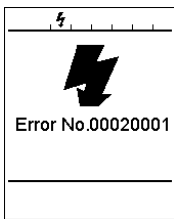
Concrete information regarding the type of error or the warning can be called up at any time, including via the Setup menu under Warnings.

Type of message	Display	Error code/ warning message	Error description
Warning		Ambient Temperature	Ambient temperature is too high
		Undervoltage	Undervoltage
		Overvoltage	Overvoltage
		Max. Force Exceeded	Max. clamping force exceeded
		Drive Overcurrent	Drive current limiting
Error		Group 0001'XXXX e.g. 00010001	Device has overheated Solution: Let the device cool
		Group 0002'XXXX e.g. 00020001	Overvoltage or undervoltage of the line voltage Solution: Check voltage source
		Group 0020'XXXX e.g. 00200001	Heating element is faulty Solution: Replace heating element
Error 1		Group 0004'XXXX e.g. 00040001	Hardware error
		Group 0008'XXXX e.g. 00080001	Thermocouple is defective
		Group 0200'XXXX e.g. 02000001	Communication module error
		Group 0400'XXXX e.g. 04000001	Drive error





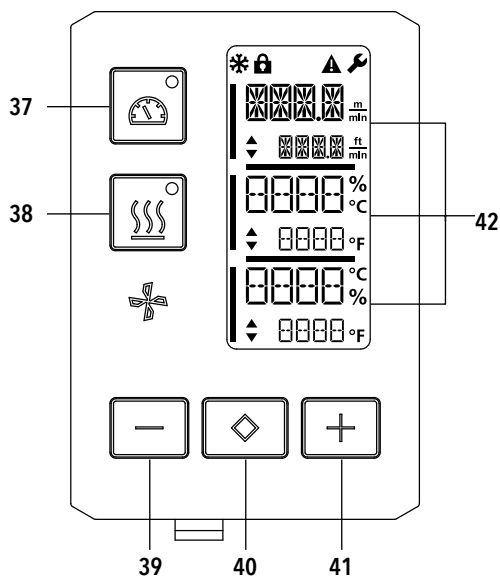

## 9. TWINNYT5 control panel



- 37. Drive "On/Off" key with status LED
- 38. Heating "On/Off" key with status LED
- 39. "Minus" key
- 40. "Confirm" key
- 41. "Plus" key
- 42. Display fields

The actual values are displayed in large font and the setpoint values in small font. The cursor is located on the left-hand side and the parameter unit on the right-hand side.

### 9.1 Symbols

Symbol	Meaning
	<b>Key lock active</b>
	<b>Cool down mode</b> Symbol for cool-down process
	<b>Error pending</b> See Chapter Error messages (TWINNYT5)
	<b>Service</b>

## 9.2 Status LED display

### Heating

The LED on the **Heating "On/Off" key (38)** displays the respective condition of the heating.

LED status Heating On/Off (38)	Condition
LED off	Heating is switched off
LED flashes green	Heating is switched on. Temperature is outside the tolerance range
LED continuously green	Heating is switched on. Temperature is within the tolerance range

### Drive

The LED on the **Drive "On/Off" key (37)** displays the condition of the drive.

LED status Drive On/Off (37)	Condition
LED off	Drive is switched off
LED continuously green	Drive is switched on

### Heating and drive

If the two LEDs for the **Heating "On/Off" (38) key** and the **Drive "On/Off" (37) key** flash simultaneously, an error is pending (see Chapter Error messages).

## 9.3 Setting the parameter units

The units for the welding speed and for the temperature can be adjusted.

Temperature:  $^{\circ}\text{C}$  or  $^{\circ}\text{F}$

Speed:  $\frac{\text{m}}{\text{min}}$  or  $\frac{\text{ft.}}{\text{min}}$

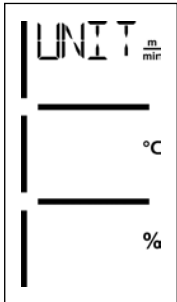

- Hold down the **Drive "On/Off" (37)** and **Heating "On/Off" (38)** keys and switch on the device using the **main switch (20)**. "UNIT" then appears on the display.
- Press the **Confirm key (40)** to confirm and set the desired units using the **Plus/Minus keys (39/41)**.
- Press the **Confirm key (40)** to confirm and use the **Plus key (41)** to select "SAVE". Press the **Confirm key (40)** to confirm; the units are then saved.

The device then restarts automatically.

## 9.4 Key lock

The TWINNYT5 has a key lock. It blocks the five keys on the control panel. The key lock is activated or deactivated by pressing the **Minus (39)** and **Plus (41)** keys for at least 3 seconds. When the key lock is activated, this is indicated at the top left of the display.

## 10. Commissioning the TWINNYT5

### 10.1 Work environment and safety



#### Danger of fire and explosion

The welding machine can become an ignition source for fire and explosion. It must therefore not be used near explosive gases or flammable materials. To avoid burning of the material to be welded, please read the material safety data sheet from the material manufacturer. The welding machine must only be used in the open or in a well-ventilated area.



#### Risk of poisoning

When PVC is overheated, toxic hydrogen chloride vapors are produced. Therefore, work must always be carried out in a well-ventilated area. In addition, the specifications of the material manufacturer must always be observed and complied with when working with PVC.

#### Power cord and extension cable

- The **power cord (1)** must be able to move freely and must not hinder the user or third parties during work (danger of tripping).
- The extension cables must be authorized for the utilization site (e.g., outdoors) and be marked accordingly. Take into account the necessary minimum cross-section for extension cables, as required.

230 V~	up to	50 m	<b>3 × 1,5 mm<sup>2</sup></b>
		up to	<b>100 m 3 × 2,5 mm<sup>2</sup></b>
120 V~	up to	50 m	<b>3 × 1,5 mm<sup>2</sup></b>
		up to	<b>100 m 3 × 2,5 mm<sup>2</sup></b>

#### Power plants for energy supply

When using power plants as an energy supply, please ensure that the power plants are grounded and equipped with residual-current circuit breakers.

For the nominal output of the power plants, the formula  $2 \times$  nominal output of the hot-air welder applies.

### 10.2 Setting the welding parameters



Connect the device to a **socket with a protective conductor**. Any interruption of the protective conductor inside or outside of the device is not permitted. Only use extension cables with protective conductors.



The nominal voltage specified on the device must match the local line voltage. If the line voltage fails, switch off the main switch and swivel the hot-air blower into the park position.



If the device is being used on construction sites, a residual-current circuit breaker must be used to protect site personnel.

#### Starting the device

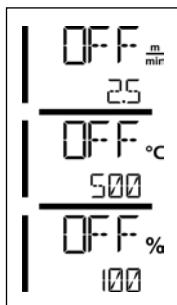
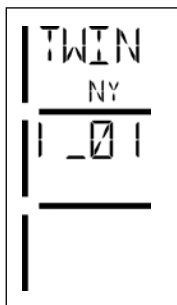

- Once you have prepared the work environment and the hot-air welder in accordance with the description, switch on the hot-air welder using the **main switch (20)**.
- After startup, the Start screen will appear briefly in the display with the version number of the current software release and the device designation.
- If the device was allowed to cool down beforehand, this will be followed by a static display of the setpoints.
- **The heating is not yet switched on at this stage.**



### CAUTION!

Exceeding the maximum welding force of 1000 N can cause mechanical damage to the device.



### Risk of crushing and shearing

Mechanically moving parts can cause hand injuries. Only hold the automatic hot-air welding machine by the handles provided for this purpose.

## Adjusting the welding force

When welding materials up to a thickness of 3 mm, the **welding force module (6)** on the TWINNYT5 prevents an excessive welding force from being set. A smaller welding force is applied for thinner materials and a greater force for thicker materials. The welding force can be increased or decreased slightly by rotating the **adjustment ring (43)**. Proceed as follows to adjust the welding force:

- Unlock the **clamping lever lock (5)** and open the **clamping lever (4)**.
- Unlock the **adjustment ring lock (44)**.
- Rotate the **adjustment ring (43)** on the **welding force module (6)**. Rotating it in the "+" direction increases the welding force and rotating it in the "-" direction decreases it. The **adjustment ring (43)** on the **welding force module (6)** can be rotated by a maximum of 360°.
- Once the desired welding force has been set, lock the **adjustment ring lock (44)** again.
- If you do not know which welding force to set, place the **adjustment ring (43)** in the middle position. After a test weld, you can increase or decrease the welding force if necessary.

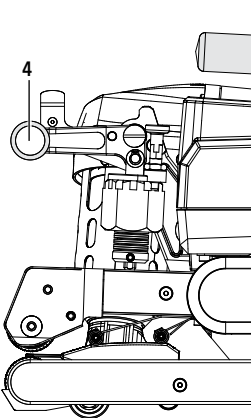

Clamping lever (4) closed

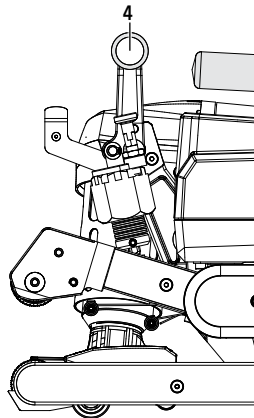

Clamping lever (4) open

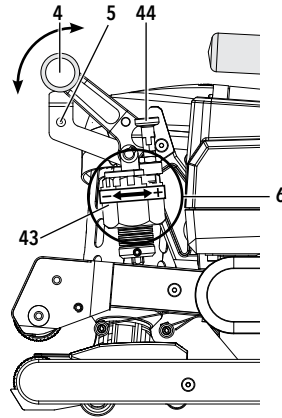

## Setting the speed, temperature, and air volume before welding

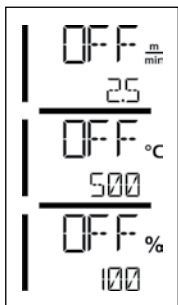

If the drive is switched off, then the welding parameters for temperature, air volume, and speed are set as follows in the **display fields (42)**:

- Using the **Confirm key (40)**, you can set the cursor to the desired parameter.
- The values of the selected parameter can be adjusted using the **Minus/Plus keys (39/41)**.

When the drive is switched on, the welding parameters are set in exactly the same way and transferred immediately. The cursor automatically switches back to the drive speed row 5 seconds after the entry has been made.

### 10.3 Preparation for welding

- The maximum overlap width is 125 mm.
- The sealing sheets must be clean and dry between the overlaps and on the upper and lower side.

### 10.4 Welding sequence



- **Caution:** Before the automatic welder is used, test welds are to be carried out in accordance with the welding instructions of the material manufacturer and with national standards or guidelines. The test welds must be checked.
- **Caution:** If the heating is switched on but the device is not welding or if the device is in Cool down mode, the **hot-air blower (19)** must be in the park position. Otherwise, the device may become damaged.
- **Caution:** Changing the position of the hot-air blower also changes the center of gravity of the device. Take this into account when lifting the device.
- **Caution:** When the hot-air blower is in the welding position, the guide rod extends beyond the device. Take this into account when handling the device.

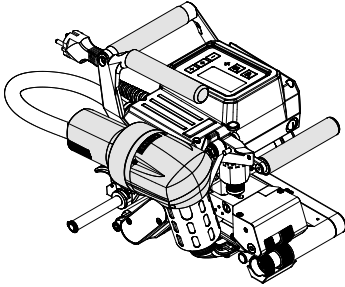

Hot-air blower (19) in welding position

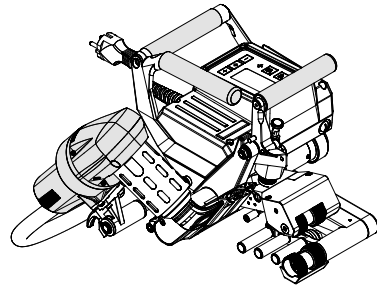

Hot-air blower (19) in park position

### Commencing welding



#### Moving parts must not be touched.

There is a risk of inadvertently becoming caught and being pulled in. Do not wear articles of clothing such as scarves or shawls. Tie up long hair or protect it by wearing headgear.



#### Risk of burning

Do not touch heating element tube and nozzle when they are hot. The device should always be allowed to cool down first. Do not point the hot air flow at people or animals.

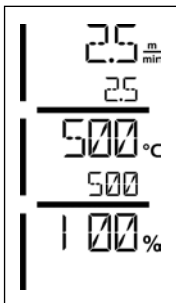

- Once you have set all welding parameters in line with your requirements, start the heating and the drive.
- Use the **Heating On/Off (38)** key to start the heating and the **Drive On/Off (37)** to start the drive. The **Heating On/Off (38)** key must be held down for 2 seconds.
- The status LED lights up as soon as the heating is switched on. If an arrow pointing upward appears on the display next to the set temperature, the actual temperature is increasing.
- Make sure that the welding temperature has been reached before commencing work (heating-up time is 3 – 5 minutes).
- Insert the hot-air welder into the overlapping plastic sheets.
- Pull the lever for the **hot-air blower lock (18)**, lower the **hot-air blower (19)**, and guide the **welding nozzle (15)** between the overlapping sheets up to the stop. Make sure that the lever for the **hot-air blower lock (18)** engages in the welding position.
- Close the **clamping lever (4)** so that the **clamping lever lock (5)** engages.

## During welding

- During the welding process, the hot-air welder can be guided along the overlap using the **handles (2)**, the **clamping lever (4)**, or the optional guide bar.
- The welding speed, air volume, and air temperature can be adjusted at any time during welding (see Chapter Setting the speed, temperature, and air volume).

## Finishing welding

- Unlock the **clamping lever lock (5)** and open the **clamping lever (4)** shortly before the end of the welding seam. The **upper drive/pressure roller (9)** and the **lower drive/pressure roller (11)** must never run in contact with one another.
- Next, pull the lever for the **hot-air blower lock (18)**, guide the **welding nozzle (15)** away from the overlap, and swivel the **hot-air blower (19)** into the park position.
- Make sure that the lever for the **hot-air blower lock (18)** engages in the park position.
- **Caution:** If the heating is switched on but the device is not welding or if the device is in Cool down mode, the **welding nozzle (15)** must be in the park position. Otherwise, the device may become damaged.

## 10.5 Switching off the device

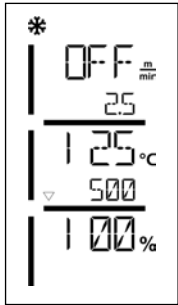

- Switch the drive and heating off using the **Drive On/Off (37)** and **Heating On/Off (38)** keys. The **Heating On/Off (38)** key must be held down for 2 seconds.
- The "Heating off" display appears and the device switches to Cool down mode (see Cool down mode).
- The blower switches off automatically after approx. 6 minutes.
- Now switch off the device with the **main switch (20)** and disconnect the **power cord (1)** from the electrical network.



- Wait until the device has cooled down.
- Check the **power cord (1)** and plug for electrical and/or mechanical damage.
- Use a wire brush to clean the **welding nozzle (15)** and **drive/pressure rollers (9/11)**.

## 11. Error messages

Type of message	Display	Error code/warning message	Error description
Error	<p>The error display shows:                     <ul style="list-style-type: none"> <li>'ERR0' with a triangle warning symbol above the '0'.</li> <li>'R' below 'ERR0'.</li> <li>'0008' below 'R'.</li> <li>'000 I' below '0008'.</li> </ul> </p>	Group 0001'XXXX e.g. 00010001	Device has overheated Solution: Let the device cool
		Group 0004'XXXX e.g. 00040001	Hardware error
		Group 0008'XXXX e.g. 00080001	Thermocouple is defective
		Group 0400'XXXX e.g. 04000001	Drive error

## 12. Settings on the TWINNYT7/T5



The device must have cooled down and the main switch must have been switched off before components on the automatic welder are dismantled or assembled. The power cord must have been disconnected from the power supply.

### 12.1 Replacement of pressure rollers

Depending on the application, you can use different **drive/pressure rollers (9/11)** on the TWINNY (see Accessories).

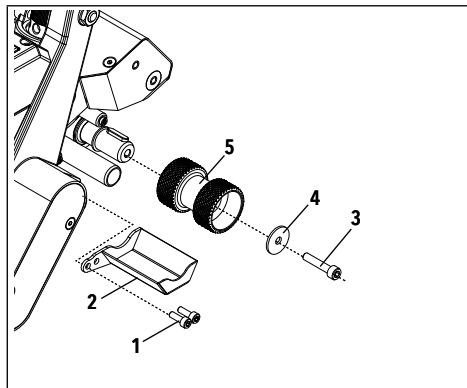

#### Dismantling the lower drive/pressure roller (11):

Sequence no. 1 - 5

#### Assembling the lower drive/pressure roller (11):

Reverse sequence no. 5 - 1

1. Cheese head screws
2. Roller cover
3. Cheese head screw
4. Washer
5. Pressure roller

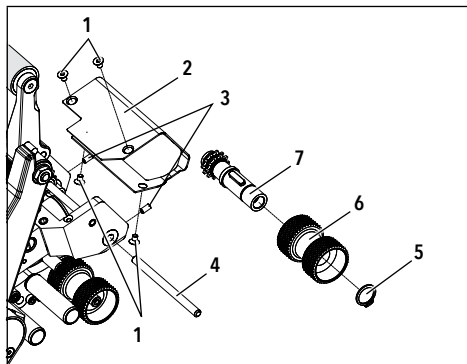

#### Dismantling the upper drive/pressure roller (9):

Sequence no. 1 - 7

#### Assembling the upper drive/pressure roller (9):

Reverse sequence no. 7 - 1

1. Cheese head screw (4x)
2. Protective plate, swivel head
3. Grub screws
4. Axle
5. Retaining ring
6. Pressure roller
7. Drive axle with parallel key

## 12.2 Replacing the welding nozzle

Depending on the application, you can use different **welding nozzles (15)** on the TWINNY (see Accessories). Swivel the **hot-air blower (19)** into the park position to replace the **welding nozzle (15)**.

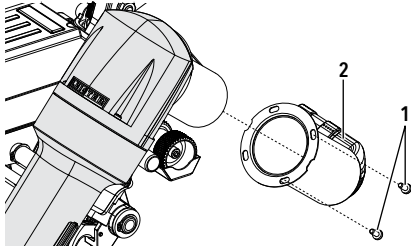

### Dismantling the welding nozzle (15):

Sequence no. 1 - 2

### Assembling the welding nozzle (15):

Reverse sequence no. 2 - 1

1. Mounting screws
2. Welding nozzle

Caution: Once the welding nozzle has been assembled, the insulation tube must always be inserted between the welding nozzle and heating element.

## 12.3 Assembling the field kit

If a greater floor clearance or larger track rollers are required for the automatic welder, the standard track rollers can be replaced by the field kit.

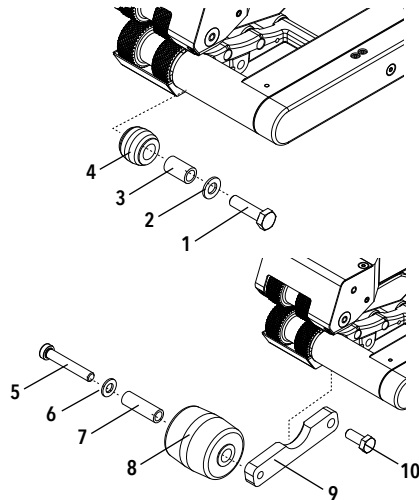

### Dismantling the rear track roller (10):

Sequence no. 1 - 4

### Assembling the rear field kit:

Sequence no. 5 - 10

### Dismantling the rear field kit:

Sequence no. 10 - 5

### Assembling the rear track roller (10):

Sequence no. 4 - 1

1. Hexagon screw
2. Washer
3. Bushing
4. Small roller
5. Cheese head screw
6. Washer
7. Bushing
8. Large roller
9. Arm
10. Hexagon screw



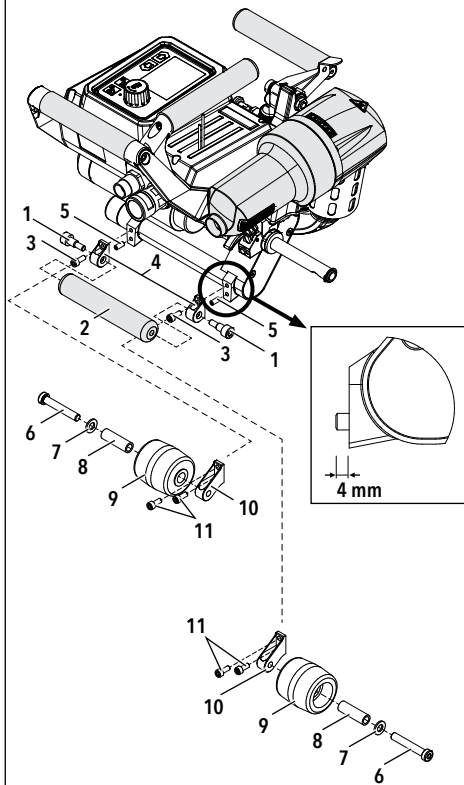

**Dismantling the front track roller (16):**

Sequence no. 1-5

**Assembling the front field kit:**

Sequence no. 6-11

**Dismantling the front field kit:**

Sequence no. 11-6

**Assembling the front track roller (16):**

Sequence no. 5-1

1. Cheese head screw (2x)
2. Small roller
3. Cheese head screw (2x)
4. Holder for roll, small (2x)
5. Grub screw (2x)
6. Cheese head screw (2x)
7. Washer (2x)
8. Bushing (2x)
9. Large roller (2x)
10. Holder for roll, large (2x)
11. Cheese head screw (4x)

## 12.4 Assembling the guide bar

Using the guide bar, the automatic welder can be routed with an upright posture.

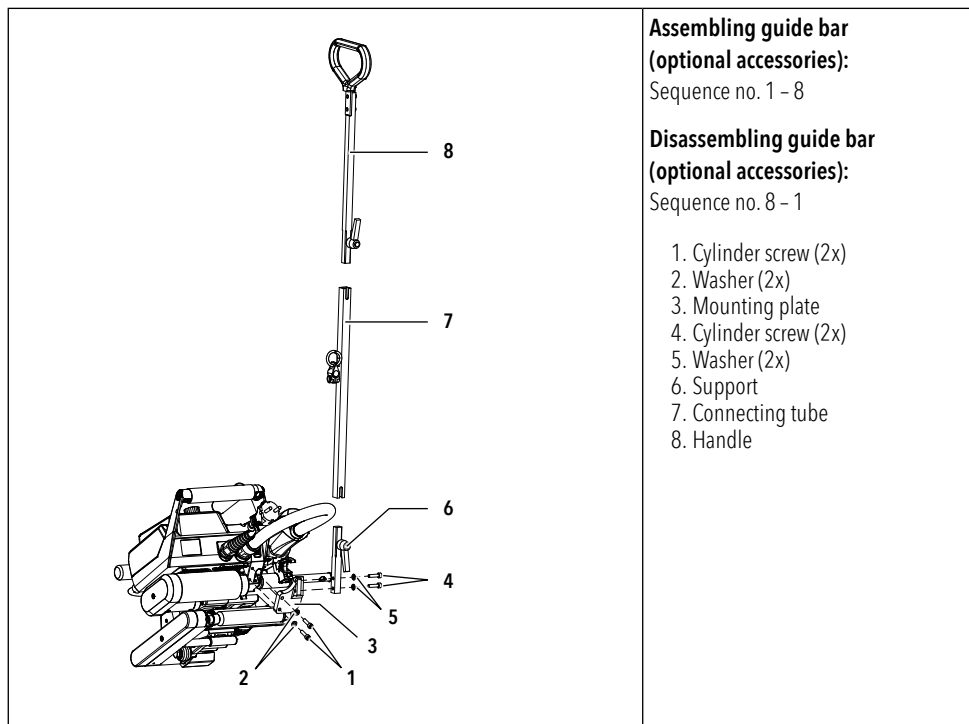

## 13. Disposal



**Do not dispose of electrical equipment with household refuse.**

Electrical appliances, accessories and packaging should be recycled in an environmentally friendly manner. When you are disposing of our products, please observe the national and local regulations.

## 14. Declaration of conformity

### EU Declaration of Conformity

**Leister Technologies AG, Galileo-Strasse 10, 6056 Kaegiswil, Switzerland** confirms that this product fulfills the requirements of the following EU Guidelines in the models that we have made available for purchase.

Directives: 2006/42/EC, 2014/30/EU, 2011/65/EU

Harmonized standards: EN ISO 12100, EN 60335-1, EN 60335-2-45, EN 55014-1, EN 55014-2, EN 61000-3-2, EN 61000-3-3, EN 61000-6-2, EN 62233, EN IEC 63000

Kaegiswil, 04/14/2021

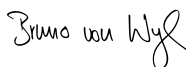

Bruno von Wyl, CTO



Christoph Baumgartner, GM

---

### UK Declaration of Conformity

**Leister Technologies AG, Galileo-Strasse 10, 6056 Kaegiswil, Switzerland** confirms that these products, in the versions as brought into circulation through us, fulfil the requirements of the following UK Statutory Instruments.

UK Statutory

Instruments: 2008 No. 1597, 2016 No. 1091, 2012 No. 3032

Designated BS EN ISO 12100, BS EN 60335-1, BS EN 60335-2-45, BS EN 55014-1, BS EN 55014-2,

Standards: BS EN 61000-3-2, BS EN 61000-3-3, BS EN 61000-6-2, EN 62233, BS EN IEC 63000

Kaegiswil, 03/31/2021

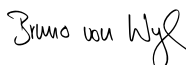

Bruno von Wyl, CTO



Christoph Baumgartner, GM

## Warranty

- The guarantee or warranty rights granted for this device by the direct distribution partner/salesperson apply from the date of purchase.
- In the event of a guarantee or warranty claim (verification by invoice or delivery note), manufacturing or processing errors will be rectified by the sales partner through replacement delivery or repair.
- Other guarantee or warranty claims are excluded within the framework of mandatory law.
- Damage resulting from natural wear, overload, or improper handling are excluded from the warranty.
- Heating elements are excluded from warranty obligations or guarantees.
- Guarantee or warranty claims cannot be asserted for devices that have been converted or changed by the purchaser or for which non-original Leister spare parts have been used.

⇒ Sales and Service Centers



### **Leister Technologies AG**

Galileo-Strasse 10

6056 Kaegiswil

Switzerland

+41 41 662 74 74

leister@leister.com

**leister.com**