

LEISTER®



VARIANT T1



Leister Technologies AG
Galileo-Strasse 10
CH-6056 Kaegiswil/Switzerland

Tel. +41 41 662 74 74
Fax +41 41 662 74 16

www.leister.com
sales@leister.com

EN	English	Operating Instructions	20
IT	Italiano	Istruzioni d'uso	38
FR	Français	Instructions d'utilisation	56
ES	Espanõl	Instrucciones de funcionamiento	74
PT	Portugês	Instruções de funcionamento	92
NL	Nederland	Gebruiksaanwijzing	110
DA	Dansk	Betjeningsvejledning	128

DE	Deutsch	Bedienungsanleitung	
-----------	---------	---------------------	--

Wir gratulieren Ihnen zum Kauf eines Heissluft-Schweissautomaten VARIANT T1

Sie haben sich für einen erstklassigen Heissluft-Schweissautomaten entschieden, der aus hochwertigen Materialien besteht. Dieses Gerät wurde nach den neuesten Schweißtechnologien entwickelt und produziert. Jeder VARIANT T1 wird einer strengen Qualitätskontrolle unterzogen bevor er das Werk in der Schweiz verlässt.

Inhaltsverzeichnis

Anwendung, Warnung, Vorsicht		Seite	3
Konformität, Entsorgung, Technische Daten		Seite	4
Gerätebeschreibung, Bedienelemente		Seite	5
Info Icons, Aktiv Icons, Quick-Info		Seite	6
Betriebsbereitschaft, Gerätepositionierung		Seite	7
Schweissablauf		Seite	8
Transportbereitschaft, Tastenkombinationen		Seite	9
Arbeitsmodus (Kapitel 1)	1.1 Sollwertanzeige		
	1.2 Arbeitsanzeige	Seite	10
	1.3 Einstellen der Antriebsgeschwindigkeit		
	1.4 Einstellen der Schweißtemperatur	Seite	11
	1.5 Einstellen der Luftmenge		
	1.6 Längenmessung, Gebläse- und Antriebszähler	Seite	12
	1.7 Profile wählen		
	1.8 Abkühlen	Seite	13
	1.9 Standby		
	1.10 Fehlermeldungen		
Profile Setup (Kapitel 2)	2.1 Profile Setup Tastenkombination	Seite	14
	2.2 Profile erstellen		
	2.3 Standby Setup	Seite	15
FAQ		Seite	16/17
Schweissanwendungen		Seite	18
Ausführungen, Zubehör, Schulung, Wartung, Service und Reparatur, Gewährleistung		Seite	19



Bedienungsanleitung vor Inbetriebnahme aufmerksam lesen und zur weiteren Verfügung aufbewahren.

Leister VARIANT T1 Heissluft-Schweissautomat

Anwendung

Das Gerät soll nur in gut durchlüfteten Räumen eingesetzt werden. Bei Bedarf soll mit einer Absaugvorrichtung oder persönlicher Schutzausrüstung gearbeitet werden. Achten Sie darauf, das Material beim Schweissprozess nicht zu verbrennen. Prüfen Sie mit dem Materialhersteller bezüglich gesundheitsschädigender Zusatzstoffe. Die gesetzlichen Bestimmungen betreffend Gesundheitsschutz des Landes sind anzuwenden.

- Handgeführter Heissluft-Schweissautomat für Überlapp-, Saum- und Keder-Schweissnähte von Planenmaterial (PVC und ähnliche Materialien).
- **Verarbeitung nur in gut durchlüfteten Räumen**



Warnung



Lebensgefahr beim Öffnen des Gerätes, da spannungsführende Komponenten und Anschlüsse freigelegt werden. Vor dem Öffnen des Gerätes Netzstecker aus der Steckdose ziehen.



Feuer- und Explosionsgefahr bei unsachgemäßem Gebrauch von Heissluftgeräten, besonders in der Nähe von brennbaren Materialien und explosiven Gasen.



Verbrennungsgefahr! Schweissdüse nicht in heissem Zustand berühren. Gerät abkühlen lassen. Heissluftstrahl nicht auf Personen oder Tiere richten.



Gerät an eine **Steckdose mit Schutzleiter** anschliessen. Jede Unterbrechung des Schutzleiters innerhalb oder ausserhalb des Gerätes ist gefährlich!
Nur Verlängerungskabel mit Schutzleiter verwenden!



Vorsicht



Nennspannung, die auf dem Gerät angegeben ist, muss mit der Netzspannung übereinstimmen. EN 61000-3-11; $Z_{max} = 0.164 \Omega + j 0.102 \Omega$. Gegebenenfalls Elektrizitäts-Versorgungs-Unternehmen konsultieren. Bei **Netzausfall** Heissluftgebläse ausfahren.



FI-Schalter beim Einsatz des Gerätes auf Baustellen ist für den Personenschutz dringend erforderlich.



Gerät **muss beobachtet** betrieben werden. Wärme kann zu brennbaren Materialien gelangen, die sich ausser Sichtweite befinden.



Gerät darf nur von **ausgebildeten Fachleuten** oder unter deren Aufsicht benützt werden. Kindern ist die Benützung gänzlich untersagt.



Gerät **vor Feuchtigkeit und Nässe schützen**.

Gerät darf nicht am Zusatzgewicht angehoben werden.

Konformität

Leister Technologies AG, Galileo-Strasse 10, CH-6056 Kaegiswil/Schweiz bestätigt, dass dieses Produkt in der von uns in Verkehr gebrachten Ausführung die Anforderungen der folgenden EU-Richtlinien erfüllt.

Richtlinien: 2006/42/EC, 2014/30/EU, 2011/65/EU
 Harmonisierte Normen: EN ISO 12100, EN 55014-1, EN 55014-2, EN 61000-3-2, EN 61000-3-3, EN 61000-3-11 (Z_{max}), EN 61000-6-2, EN 62233, EN 60335-1, EN 60335-2-45, EN IEC 63000

Kaegiswil, 05.11.2020

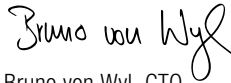
 Bruno von Wyl, CTO

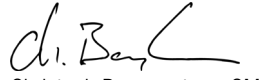
 Christoph Baumgartner, GM

Entsorgung



Elektrogeräte, Zubehör und Verpackungen sollen einer umweltgerechten Wiederverwertung zugeführt werden. Werfen Sie Elektrogeräte nicht in den Hausmüll!

Technische Daten

Spannung	V~	200	230	400 (2LNPE)	V~	200	230	400 (2LNPE)
Leistung	W	4200	3680	5700	W	4200	3680	5700
Frequenz	Hz	50/60			Hz	50/60		
Temperatur	°C	100 – 620 stufenlos			°F	212 – 1148 stufenlos		
Antrieb	m/min.	1.5 – 18 stufenlos			ft/min	4.9 – 59.1 stufenlos		
Luftmenge	%	40 – 100			%	40 – 100		
Emissionspegel	L _{pA} (dB)	70			L _{pA} (dB)	70		
Gewicht	kg	22			lbs	48.5		
ohne Netzanschlussleitung								
Masse L × B × H	mm	500 × 400 × 195			inch	19.7 × 15.8 × 7.7		
Konformitätszeichen		CE				CE		
Schutzklasse I		⊕				⊕		

Anschlussspannung nicht umschaltbar

Technische Änderungen vorbehalten

Gerätebeschreibung

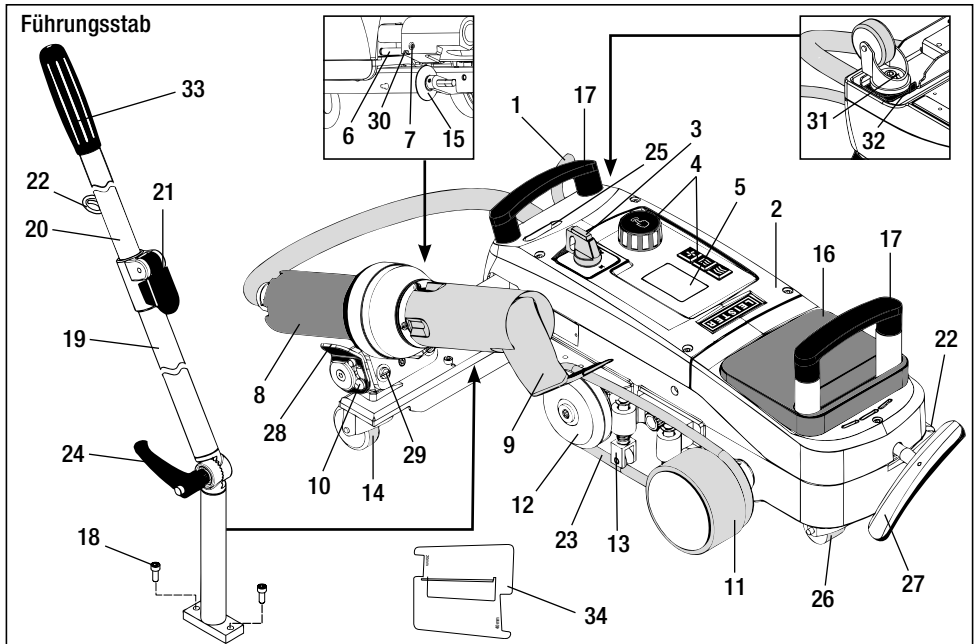

- | | | |
|--|---------------------------------------|--|
| 1 Netzanschlussleitung | 12 Umlenkrolle | 24 Hebelschraube |
| 2 Gehäuse | 13 Niederhalter | Führungsstab-Unterteil |
| 3 Hauptschalter | 14 Lenkrolle | 25 Einstellschrauben Schwenkachse |
| 4 Bedienelemente | 15 Führungsrolle | 26 Transportrolle |
| 5 Display | 16 Zusatzgewicht | 27 Griff für Abhebevorrichtung |
| 6 Anfahrssensor | 17 Traggriff | 28 Haltegriff |
| 7 Gewindestift für Anfahrssensor-Einstellung | 18 Zylinderschraube | 29 Winkeleinstellung Gerätehalter |
| 8 Heissluftgebläse | 19 Führungsstab-Unterteil | 30 Arretierschraube für Schweißsposition |
| 9 Schweißdüse | 20 Führungsstab-Oberteil | 31 Arretierschraube für Spurfineinstellung |
| 10 Arretiernocken für Heissluftgebläse | 21 Klemmhebel | 32 Hebel für Spurfineinstellung |
| 11 Andrückrolle | 22 Halterung für Netzanschlussleitung | 33 Griff Führungsstab |
| | 23 Rundriemen | 34 Düsenlehre |

Hauptschalter (3)



Zum Ein- / Ausschalten des Heissluft-Schweißautomaten VARIANT T1

Bedienelemente (4)



e-Drive

Der e-Drive dient als Navigator.

Er hat zwei Funktionen:



Nach links oder rechts drehen, um diverse Menüs oder Werte einzustellen



Drücken, um zu bestätigen oder zu aktivieren



Antrieb

Einstellen der Antriebsgeschwindigkeit



Heizung

Einstellen der Schweißtemperatur



Gebälse

Einstellen der Luftmenge

Info Icons

Die folgenden Icons werden zur Information auf dem Display angezeigt.



Schweisssdüse kühlt ab



Gerät im Standby-Modus,
Gerät wird nach Ablauf
abschalten



Autorisierte Service-Stelle
kontaktieren



Zeigt an, dass die Temperatur am Steigen ist



Zeigt an, dass die Temperatur am Sinken ist



Fortschrittsbalken

Aktiv Icons

Die folgenden Icons werden im Display angezeigt und durch drücken des e-Drive  ausgelöst.



Einschalten von Heizung und Gebläse
(falls Gebläse noch nicht läuft)



Stoppen des Antriebs



Starten des Antriebs



Automatisches Abkühlen
(Heizung aus, Gebläse ein)



In der Struktur nach oben (zurück
in das vorhergehende Programm)



Enter, Bestätigen



Profile auswählen



Geänderter Name speichern



Profil Name ändern



Auf die nächste Seite



Auf die nächste Seite



Tagesdistanz auf Null zurücksetzen

Info Icons





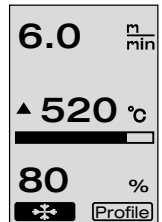
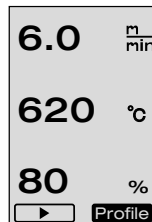











Aktiv Icons



Quick-Info

Wie starte ich den Heissluft-Schweisautomaten VARIANT T1 ?

1. Netzanschlussleitung an das elektrische Netz anschliessen 
2. **Hauptschalter (3) EIN** 
3. Taste Antrieb drücken  →  e-Drive drehen 
4. Taste Heizung drücken  →  e-Drive drehen 
5. Taste Gebläse drücken  →  e-Drive drehen 
6. e-Drive drücken  Aufheizzeit ca. 1 – 2 Minuten → 
7. Testschweissung gemäss Schweissanleitung des Materialherstellers und nationalen Normen oder Richtlinien vornehmen.
Testschweissung überprüfen.
8. Schweissung 

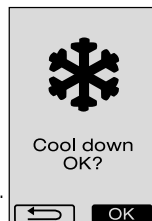
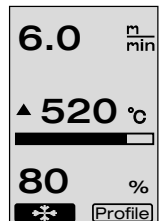

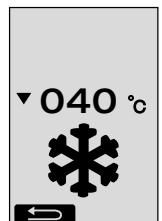

(Abb. 1)



(Abb. 2)

Wie schalte ich den Heissluft-Schweisautomaten VARIANT T1 aus?

1. e-Drive drücken  (Abb. 1).
2. «Cool down OK» e-Drive drücken  und ca. 4 Minuten abkühlen (Abb. 2).
Gebläse schaltet automatisch aus.
3. Nach abgekühlter **Schweisssdüse (9) Hauptschalter (3) AUS OFF** 

Betriebsbereitschaft

- Vor Inbetriebnahme **Netzanschlussleitung (1)** und Stecker sowie Verlängerungskabel auf elektrische und mechanische Beschädigung überprüfen.
- Die Grundeinstellung der **Schweissdüse (9)** wird im Werk vorgenommen
- Grundeinstellung der **Schweissdüse (9)** kontrollieren
 - Die Kontrolle kann mittels **Düsenlehre (34)** oder gemäss Detail A und B erfolgen.

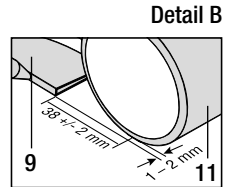
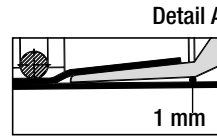
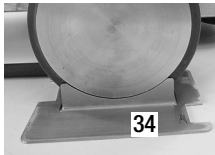

- **Führungsstab** mit **Zylinderschrauben (18)** montieren.
 - **Führungsstab-Unterteil (19)** mittels **Hebelschraube (24)** und **Führungsstab-Oberteil (20)** mittels **Klemmhebel (21)** in die gewünschte Position bringen.
 - Zugentlastung von **Netzanschlussleitung (1)** in **Halterung (22)** am Führungsstab oder am Fahrgestell einhängen.

- **Zusatzgewicht (16)** einlegen (max. zwei Zusatzgewichte)

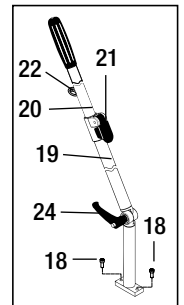
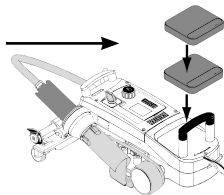

Gerät an Nennspannung anschliessen. Nennspannung, die auf dem Gerät angegeben ist, muss mit der Netzspannung übereinstimmen.

Bei **Netzausfall Heissluftgebläse (8)** in Parkposition ausfahren.

Gerätepositionierung

- Das Planenmaterial muss zwischen der Überlappung sowie auf der Ober- und Unterseite sauber sein.
- **Schweissdüse (9)**, **Andrückrolle (11)**, **Umlenkrolle (12)** und **Rundriemen (23)** sowie **Niederhalter (13)** müssen sauber sein.
- Ist der Heissluft-Schweissautomat nicht in Transportbereitschaft, mittels **Griff (27)** der Abhebevorrichtung Gerät anheben. Die **Transportrollen (26)** sind jetzt in Funktion.
- Heissluft-Schweissautomat auf Schweissposition fahren.
- Mit **Griff (27)** den Heissluft-Schweissautomaten in Schweissposition absenken. Die **Transportrollen (26)** haben keine Funktion mehr und sind somit entlastet.
- **Führungsrolle (15)** nach unten schwenken
- **Führungsrolle (15)** muss parallel zur **Andrückrolle (11)** sein (Detail C).

Transportbereitschaft
Griff links

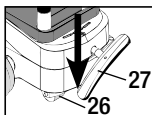

Schweissposition
Griff rechts

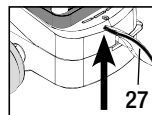

Detail C

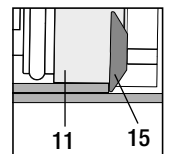

Schweissablauf

• Vorbereitung



Testschweissung gemäss Schweissanleitung des Materialherstellers und nationalen Normen oder Richtlinien vornehmen. Testschweissung überprüfen.

- Schweissparameter Antrieb, Heizung und Gebläse einstellen (Kapitel 1, Arbeitsmodus)
- Schweisstemperatur muss erreicht sein (Aufheizzeit ca. 1–2 min.)

• Start Schweissung

- Führungsrolle (15) nach unten schwenken
- Heissluftgebläse (8) leicht auf- und einschwenken, bis der Arretiernocken (10) aus der Aussparung geschoben ist. Heissluftgebläse (8) sofort absenken.



ACHTUNG: Wird das Heissluftgebläse (8) zu weit eingeschoben und abgesenkt, kommen Schweißsdüse (9) und Andrückrolle (11) in Berührung. Das Heissluftgebläse (8) kann so nicht abgesenkt werden.

- Oberes Planenmaterial im Bereich der Führungsrolle leicht anheben und durch Schieben des Heissluftgebläses (8) die Schweißsdüse (9) zwischen die überlappte Planen bis zum Anschlag einfahren.



- Antriebsmotor startet automatisch. Kein automatischer Start (Kapitel FAQ, Seite 17)
- Maschine kann mit Bedienelementen (4) Antrieb  und e-Drive  manuell gestartet werden
- Wird der Antrieb über  und e-Drive  gestartet und anschliessend die Schweißsdüse (9) eingeschoben, fährt der Heissluft-Schweissautomat nach dem ausschwenken der Schweißsdüse (9) für ca. 30 cm weiter (verzögertes Ausschalten des Antriebs).
- Heissluft-Schweissautomat kann am Griff Führungsstab (33), Traggriff (17) oder am Haltegriff (28) entlang der Überlappung geführt werden. Führen Sie den Heissluft-Schweissautomaten ohne Druck auf den Griff Führungsstab (33), Traggriff (17) oder Haltegriff (28) beim Schweißen. Druck kann zu Schweißfehlern führen. Position der Führungsrolle (15) beachten.

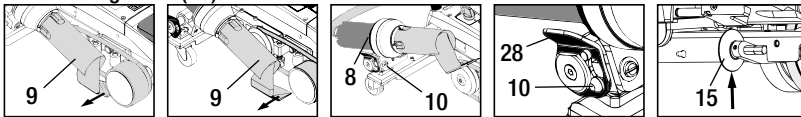

• Ende Schweissung

- Nach der Schweissung die Schweißsdüse (9) mittels Heissluftgebläse (8) aus der Schweissposition nach rechts schieben und anheben.
- Heissluftgebläse (8) nach rechts schieben bis der Arretiernocken (10) in die Aussparung des Haltegriffes (28) einrastet. Heissluftgebläse (8) ist in Parkposition.
- Führungsrolle (15) nach oben schwenken

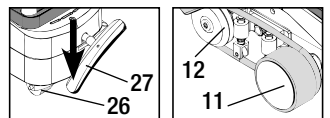

- Absenken der Transportrollen (26) durch Schwenken des Griffes (27). Dadurch werden die Andrückrolle (11) und Umlenkrolle (12) für den Transport entlastet.



- Nach Beendigung der Schweissarbeiten mittels e-Drive  (2 × drücken) Heizung ausschalten, dadurch wird die Schweißsdüse (9) abgekühlt und das Gebläse schaltet nach ca. 4 Minuten automatisch aus (Kapitel 1.8, Abkühlen).
- Hauptschalter (3)  ausschalten



Netzanschlussleitung vom elektrischen Netz trennen.

- Schweißsdüse (9) mit Messingbürste reinigen

Transportbereitschaft

- **Führungsrolle (15)** nach oben schwenken.
- **Heissluftgebläse (8)** nach rechts schieben bis der **Arretiernocken (10)** in die Aussparung des **Haltegriffes (28)** einrastet. **Heissluftgebläse (8)** ist in Parkposition.
- Absenken der **Transportrollen (26)** durch Schwenken des **Griffes (27)**. Dadurch werden die **Andrückrolle (11)** und **Umlenkrolle (12)** für den Transport entlastet.

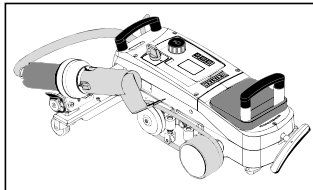
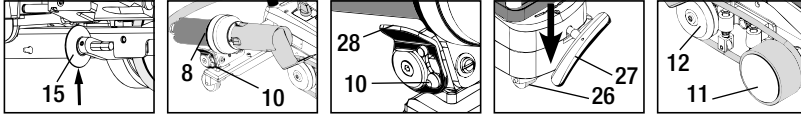

Fahren



Tragen

Tastenkombinationen

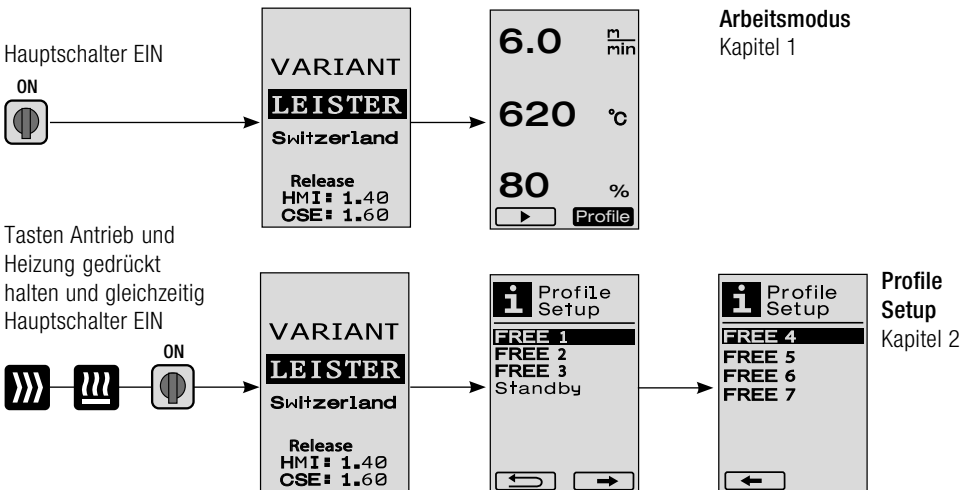

1. Arbeitsmodus

1.1 Sollwertanzeige (nach Einschalten des Gerätes)

Hauptschalter (3) EIN 

- Nach dem Einschalten des Geräts erscheinen die zuletzt eingestellten Werte auf dem **Display (5)** (Abb. 3).
- In diesem Menü sind Heizung, Gebläse und Antrieb ausgeschaltet.
- Der Anwender kann hier mit den **Bedienelementen (4)** alle Einstellungen vornehmen, welche in den folgenden Kapiteln beschrieben sind.
- Ist die Heizelement-Temperatur beim Einschalten jedoch grösser als 80°C, wechselt die Anzeige sofort in den Cool Down Modus (Kapitel 1.8 Abkühlen) in welchem das Gebläse immer mit voller Leistung betrieben wird und so die **Schweissdüse (9)** abkühlt. Aus diesem Modus kann durch Drücken des e-Drive  zu jeder Zeit wieder in den Arbeitsmodus gewechselt werden.
- Erreicht die Heizelement-Temperatur beim Abkühlen 60°C, läuft das Gebläse noch 2 Minuten weiter und schaltet anschliessend automatisch ab. Das **Display (5)** wechselt in die Sollwertanzeige zurück (Abb. 3).
- Durch Drehen des e-Drive  auf Profile können die verschiedenen Schweissprofile ausgewählt werden (Abb. 4; Kapitel 1.7, Profile wählen).

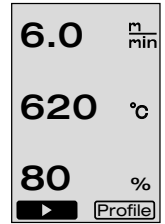





(Abb. 3)



(Abb. 4)

1.2 Arbeitsanzeige

- Durch Drücken des e-Drive  werden Heizung und Gebläse gestartet, und die Sollwertanzeige wechselt in die Arbeitsanzeige.
- Beim Aufheizen der **Schweissdüse (9)** wird dies auf dem **Display (5)** mit Fortschrittsbalken, Pfeil ▲ (nach oben) und Ist-Wert der Schweisstemperatur (blinkend) angezeigt (Abb. 5). Ist der Sollwert der Schweisstemperatur erreicht, werden Pfeil und Fortschrittsbalken nicht mehr angezeigt (Abb. 6).
- Ist die Netzspannung ausserhalb (+/- 15%) der vorgegebenen Nennspannung, wird alternierend das Symbol mit der gemessenen Unter-/Überspannung  und der  eingestellten Luftmenge angezeigt. Ist die Luftmenge 100%, wird blinkend das Symbol mit der gemessenen Unter-  /Überspannung  angezeigt (Abb. 7). (Nur bei VARIANT T1 230V~ möglich).

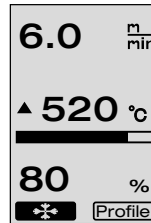

(Abb. 5)

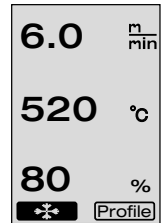

(Abb. 6)

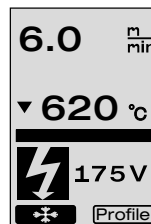

(Abb. 7)

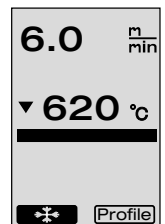

(Abb. 8)









Unter-/Überspannung kann das Schweissresultat beeinflussen!

- Wird nach einer definierten Zeit keine Taste gedrückt, **Schweissdüse (9)** NICHT in Schweissposition, wird das Standby-Menü angezeigt (Kapitel 1.9, Standby).
- Ist die **Schweissdüse (9)** in der Parkposition, sind die Menüs Cool Down (Kapitel 1.8, Abkühlen) oder Profile (Kapitel 1.7, Profile wählen) durch Drehen des e-Drive  wählbar.
- Ist die **Schweissdüse (9)** eingeschwenkt, verschwinden die beiden Menüpunkte  auf dem **Display (5)** und können nicht mehr angewählt werden.
- Während die **Schweissdüse (9)** abkühlt, wird dies mit ausgefülltem Fortschrittsbalken, Pfeil ▼ (nach unten) und blinkendem Istwert der Schweisstemperatur auf dem **Display (5)** dargestellt (Abb. 8).

1. Arbeitsmodus





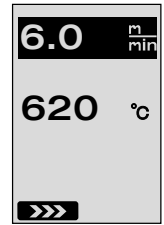

1.3 Einstellen der Antriebsgeschwindigkeit

- Mit der Taste Antrieb  kann die Antriebsgeschwindigkeit angepasst werden. Diese kann durch Drehen des e-Drive  in 0.1 m/min.-Schritten von 1.5 m/min. – 18.0 m/min. eingestellt werden. Diese Einstellung kann bei ein- oder ausgeschaltetem Antrieb vorgenommen werden. Erfolgt während 3 Sekunden keine Eingabe durch die **Bedienelemente (4)**, wird die neue Antriebsgeschwindigkeit übernommen. Auf dem **Display (5)** erscheinen die Sollwert-Arbeitsanzeige oder Cool Down (Abb. 9).
- Ist die **Schweissdüse (9)** nicht in der Schweissposition, erscheint am unteren linken Rand des **Displays (5)** das Symbol (Start)  .
- Durch Drücken des e-Drive  kann der Antrieb eingeschaltet werden, es erscheint das Symbol (Stop)  . Die Antriebsgeschwindigkeit kann direkt durch Drehen des e-Drive  verstellt werden.
- Durch erneutes Drücken des e-Drive  wird der Befehl Stop ausgeführt, der Antrieb wird ausgeschaltet. Auf dem Display erscheinen die Sollwert-Arbeitsanzeige oder Cool Down.
- Wird die Taste Antrieb  während 3 Sekunden gedrückt, wechselt die Anzeige in ein anderes Menü (siehe Kapitel 1.6 Längenmessung, Gebläse- und Antriebszähler).
- Mit der Taste Heizung  oder Taste Gebläse  kann in das jeweilige Menü gewechselt werden.



(Abb. 9)

1.4 Einstellen der Schweisstemperatur

- Mit der Taste Heizung  kann die Schweisstemperatur verändert werden. Die Schweisstemperatur ist in 10°C-Schritten von 100°C – 620°C durch Drehen des e-Drive  einstellbar. Die Einstellung wird nach 3 Sekunden übernommen, sofern innerhalb dieser 3 Sekunden keine Taste betätigt wurde (Abb. 10).
- Wird dieses Menü aus der Sollwertanzeige aufgerufen, können durch Drücken des e-Drive  Heizung und Gebläse gestartet werden. Ist die Heizung eingeschaltet, kann das Menü Cool Down ausgewählt werden (Kapitel 1.8, Abkühlen) (Abb. 11).
- Durch Drücken der Taste Heizung  während 3 Sekunden erscheint die Netzspannung unterhalb der Antriebsgeschwindigkeit. Dieser Aufruf ist nur aus der Arbeitsanzeige möglich (Kapitel 1.2). (Nur bei VARIANT T1 230V~ möglich).
- Mit der Taste Antrieb  oder Taste Gebläse  kann in das jeweilige Menü gewechselt werden.

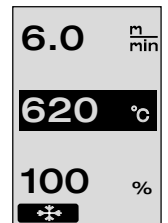



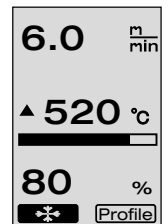



(Abb. 10)



(Abb. 11)

1. Arbeitsmodus

1.5 Einstellen der Luftmenge

- Mit der Taste Gebläse  kann die Luftmenge verändert werden. Die Luftmenge ist in 5% - Schritten von 40% – 100% durch Drehen des e-Drive  einstellbar. Die Einstellung wird nach 3 Sekunden übernommen, sofern innerhalb dieser 3 Sekunden keine Taste betätigt wurde. Ist die Luftmenge auf 100% eingestellt, erscheint keine Anzeige auf dem **Display (5)** (Abb 12).
- Wird dieses Menü aus der Sollwertanzeige aufgerufen, kann durch Drücken des e-Drive  die Heizung und das Gebläse gestartet werden.
- Das Cool Down Menü kann durch Drücken des e-Drive  ausgewählt werden (Kapitel 1.8, Abkühlen).
- Mit der Taste Antrieb  oder Taste Heizung  kann in das jeweilige Menü gewechselt werden.

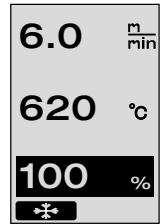

(Abb. 12)

1.6 Längenmessung, Gebläse- und Antriebszähler

- Dieses Menü (Abb. 13) erscheint, wenn die Taste Antrieb  mindestens 3 Sekunden gedrückt wird.
- Das Menü zeigt sämtliche Betriebszeiten und die Distanz an, welche das Gerät seit dem Einschalten zurückgelegt hat. Die totale Distanz (hier: 1034 m) ist nicht veränderbar und zeigt den gesamten zurückgelegten Weg seit der Inbetriebnahme an.
- Die Tagesdistanz (hier: 012 m) wird nicht automatisch zurückgesetzt, sondern kann vom Benutzer über **Reset** durch Drücken des e-Drive  auf Null zurückgesetzt werden.
- Bei den Werten Time handelt es sich um die Betriebszeit der einzelnen Komponenten des Gerätes. Dabei ist die Zeit dem Gebläse «Blow» (hier: 043:58) und dem Antrieb «Drive» (hier: 020:10) zugeordnet. Die Zeit «Total» bezieht sich auf die Betriebszeit. Sie zählt die Stunden und Minuten (hier: 143:12), während denen der **Hauptschalter (3)** eingeschaltet ist.
- Wird durch Drücken des e-Drive  der Back Pfeil  ausgewählt, gelangt man in das Menü zurück, von welchem aus die Taste Antrieb  gedrückt worden ist.

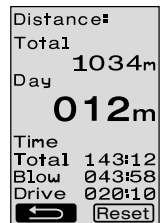

(Abb. 13)

1. Arbeitsmodus



1.7 Profile wählen

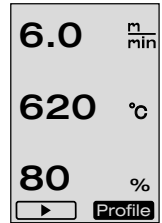

- Ist die Anzeige **Profile** rechts unten im **Display (5)** aktiviert, können durch Drücken des e-Drive  Profile geladen werden. Anschliessend erscheint die Anzeige «Select Profile». Durch Drehen des e-Drive  kann ein Profil ausgewählt werden. Die Profile FREE 1–7 können durch den Anwender selber definiert werden (siehe Kapitel 2 Profile Setup). Alle anderen Profile haben fix zugeteilte Werte und können durch den Anwender nicht definiert werden (Abb 14).



(Abb. 14)

- Durch Drehen des e-Drive  können im **Display (5)** unten links oder rechts Pfeile aktiviert werden.

Pfeil rechts  durch Drücken des e-Drive  auf die nächste Seite (Abb 15).

Pfeil links  durch Drücken des e-Drive  auf die vorherige Seite (Abb 16).

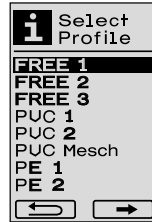

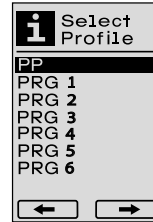

(Abb. 15)

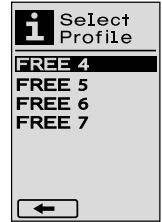

(Abb. 16)





- Wird der Back Pfeil  durch Drehen des e-Drive  aktiviert, gelangt man durch Drücken des e-Drive  in das Menü zurück, von welchem aus das Menü Profile ausgewählt worden ist (Abb 15).







Testschweissung gemäss Schweißanleitung des Materialherstellers und nationalen Normen oder Richtlinien vornehmen. Testschweissung überprüfen.

1.8 Abkühlen

- Wird das Symbol  mittels Drücken des e-Drive  ausgewählt (Abb 17), erscheint das Menü «Cool down OK?» (Abb 18). Durch Drücken des e-Drive  wird das Symbol OK unten rechts am **Displays (5)** aktiviert. Somit wird der Abkühlvorgang eingeleitet.

- Während des Abkühlvorganges wird die Luftmenge auf 100% erhöht und die momentane Schweisstemperatur angezeigt (Abb 19). Wird die Schweisstemperatur von 60 °C unterschritten, läuft das Gebläse 2 Minuten weiter und stellt nach Ablauf dieser Zeit automatisch ab. Die Anzeige wechselt in die Sollwert-Anzeige.

- Durch Drücken des e-Drive  während des Abkühlvorganges wird die Heizung gestartet und auf dem **Display (5)** erscheint die Arbeitsanzeige (siehe Kapitel 1.2 Arbeitsanzeige).

- Ist das Menü Cool Down aktiv, kann der Antrieb manuell über die Taste Antrieb  ein-/ ausgeschaltet werden. Die Tasten Heizung  und Gebläse  haben keine Funktion.

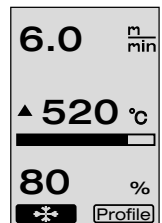

(Abb. 17)



(Abb. 18)

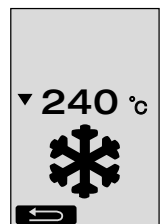

(Abb. 19)

1. Arbeitsmodus

1.9 Standby

- Ist die **Schweissdüse (9)** nicht in Schweissposition und erfolgt während der durch den Benutzer definierte Standby-Zeit keine Tasteneingabe, startet nach Ablauf des Countdowns (Abb 20) automatisch der Cool Down-Modus. Der Abkühlvorgang wird eingeleitet.
- Wird vor Ablauf des Countdowns (180 Sekunden) der e-Drive  gedrückt, wechselt das **Display (5)** in die Arbeitsanzeige (siehe Kapitel 1.2 Arbeitsanzeige).
- Einstellen der Standby-Zeit (Kapitel 2.3, Standby Setup).

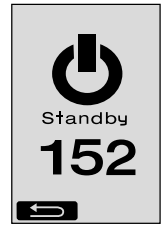

(Abb. 20)

1.10 Fehlermeldungen

- Wenn eine Fehlfunktion des Heissluft-Schweissautomaten VARIANT T1 auftritt, erscheint auf dem **Display (5)** eine Meldung, welche zusätzlich mit einem Error-Code versehen ist. Dieser Code steht für eine genauere Umschreibung des Fehlers, welcher in der unteren Liste ersichtlich ist.
- Beim Fehler 02 und beim Fehler 40 werden separate Symbole angezeigt
- Bei allen anderen Fehlern wird der Schraubenschlüssel für die Serviceaufforderung angezeigt



Error	Art des Fehlers
Err00	Steuerelektronik defekt
Err01	Unterbruch oder Kurzschluss der Temperatursonde
Err02	Heizelement / Elektronik defekt (Unterbruch in einer/beiden Wicklung/en)
Err04	Triac defekt (einer oder beide Triacs sind defekt)
Err08	Gebälsemotor defekt
Err40	Unterspannung 25% (Netzspannung 75%) nur VARIANT T1 230V~

2. Profile Setup



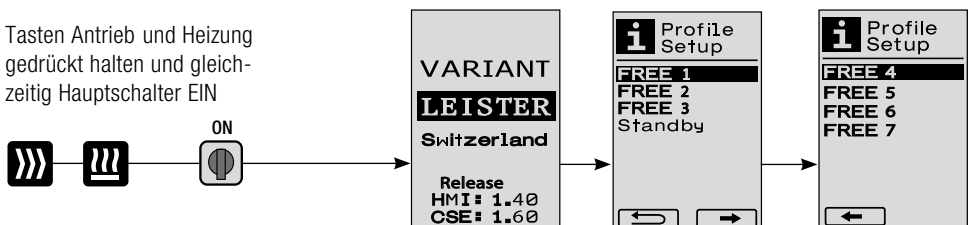

2.1 Profile Setup Tastenkombination

Tasten Antrieb und Heizung gedrückt halten und gleichzeitig Hauptschalter EIN



2. Profile Setup

2.2 Profile erstellen



- Im Profile Setup können 7 individuelle Profile angelegt werden bei welchen der Name, und alle drei Parameter Antrieb , Heizung , Gebläse  frei eingestellt und anschliessend durch Drücken des e-Drive  gespeichert werden können (Abb.21).



(Abb. 21)



- Die verschiedenen Menüpunkte können mittels **Bedienelementen (4)** angewählt werden. Durch Drücken des e-Drive  kehrt man zurück in die Profile Setup-Auswahl.

- Durch Drehen des e-Drive  können im **Display (5)** unten links oder rechts Pfeile aktiviert werden.

Pfeil rechts  durch Drücken des e-Drive  auf die nächste Seite.

Pfeil links  durch Drücken des e-Drive  auf die vorherige Seite.

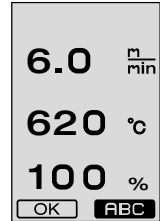

- Wird das Symbol  ABC durch Drehen des e-Drive  aktiviert, gelangt man durch Drücken des e-Drive  in das Menü Profile Name (Abb. 22).

- Im Menü Profile Name kann durch Drehen des e-Drive  die Zeichen **_ / . / A bis Z / 0 bis 9**, sowie die Pfeile links oder rechts und die Symbole Save  oder Back  ausgewählt werden.



(Abb. 22)

- Profil Name ändern

- Durch Drehen des e-Drive  können die Pfeile links oder rechts ausgewählt. Wird der Pfeil rechts durch Drücken des e-Drive  aktiviert, springt die Position im Profil Namen ein Zeichen (schwarz) nach rechts. Wird der Pfeil links durch Drücken des e-Drive  aktiviert, springt die Position im Profil Namen ein Zeichen (schwarz) nach links (Abb 23).



(Abb. 23)

- Durch Drehen des e-Drive  kann das gewünschte Zeichen (**_ / . / A bis Z / 0 bis 9**) ausgewählt werden. Durch Drücken des e-Drive  wird nun das im Profil Namen schwarz dargestellte Zeichen, durch das zuvor ausgewählte Zeichen ersetzt.

- Profil Name speichern oder verwerfen

- Wird Durch Drehen des e-Drive  das Symbol Save  angewählt, wird durch Drücken des e-Drive  der Profil Name gespeichert.

- Wird Durch Drehen des e-Drive  das Symbol Back  angewählt, wird durch Drücken des e-Drive  der Profil Name verworfen (nicht gespeichert).



Testschweissung gemäss Schweissanleitung des Materialherstellers und nationalen Normen oder Richtlinien vornehmen. Testschweissung überprüfen.

2.3 Standby Setup

- Die Standby-Zeit definiert die Zeit, welche ablaufen muss (keine Tasteneingabe, **Schweissdüse (9)** nicht in Schweissposition) bis automatisch der Abkühlvorgang (siehe Kapitel 1.8 Abkühlen) ausgelöst wird.

- Durch Drehen des e-Drive  kann die Zeit von 5 – 120 Minuten eingestellt werden. Werkseitig sind 40 Minuten eingestellt.

- Durch Drücken des e-Drive  kehrt man zurück in die Profile Setup-Auswahl.

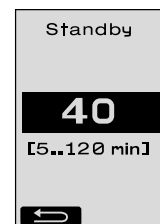

- Maschine schaltet automatisch ab
 - Mit dem Standby-Betrieb wird die Maschine nach eingestellter Zeit automatisch abgeschaltet (werkseitig 40 Minuten eingestellt).
 - Bei Bedarf Standby-Zeit erhöhen (Seite 15, 2. Profile Setup, 2.3 Standby Setup).
- Qualität der Schweissung ist mangelhaft
 - Antriebsgeschwindigkeit, Schweisstemperatur und Luftmenge überprüfen
 - **Schweissdüse (9)** mit Drahtbürste reinigen
 - **Schweissdüse (9)** ist falsch eingestellt

Einstellung der Schweissdüse (9) wie folgt vornehmen

- Schweissdüse (9)** abkühlen (Seite 13, 1. Arbeitsmodus, 1.8 Abkühlen)
- Innensechskantschrauben am Gerätehalter lösen
- Winklereinstellung mittels Schwenkbewegungen am **Heissluftgebläse (8)** vornehmen.
- Die **Schweissdüse (9)** muss (**Pfeil L**) auf der **Düsenlehre (34)** und (**Pfeil R**) auf dem Untergrund aufliegen.
- Innensechskantschrauben am Gerätehalter anziehen
- Düsenlehre (34)** in Position bringen. Skala auf **Düsenlehre (34)** beachten
- Heissluftgebläse (8)** in Schweissposition bringen
- Einstellschrauben Schwenkachse (25)** lösen
- Heissluftgebläse (8)** an **Düsenlehre (34)** parallel ausrichten
- Einstellschrauben Schwenkachse (25)** anziehen
- Düsenlehre (34)** entfernen und Testschweissung vornehmen.

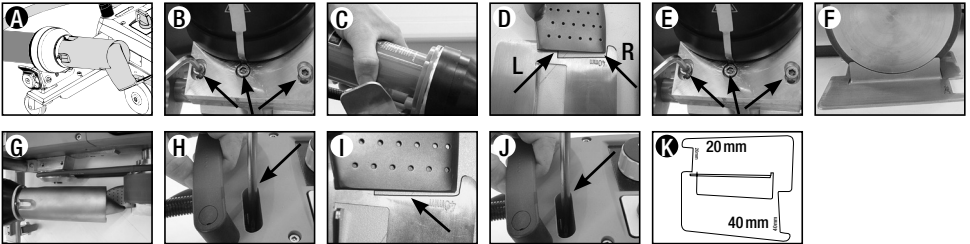

- Nicht Erreichen der eingestellten Temperatur (Anzeige Temperatur blinkt)
 - Netzspannung kontrollieren
 - Luftmenge reduzieren
 - Temperatur reduzieren
- Heissluftgebläse arretiert nicht in Schweissposition
 - Kugeldruckstück muss wie folgt eingestellt werden:
 - **Schweissdüse (9)** abkühlen (Seite 13, 1. Arbeitsmodus, 1.8 Abkühlen)
 - **Schweissdüse (9)** in Schweissposition bringen
 - Mit Schraubenzieher **Schraube (30)** leicht anziehen, danach **Schraube (30)** ca. 1/2 Drehung retour drehen.

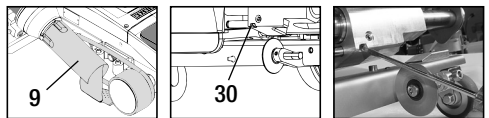

- Schweissnahtbreite ist nicht konstant
 - Feineinstellung der Führungsrolle wie folgt vornehmen:
 - **Schweissdüse (9)** abkühlen (Seite 13, 1. Arbeitsmodus, 1.8 Abkühlen)
 - **Schweissdüse (9)** in Schweissposition bringen
 - Innensechskant-Schraube der **Führungsrolle (15)** lösen
 - **Führungsrolle (15)** in die gewünschte Position schieben
 - Innensechskant-Schraube anziehen
 - Testschweissung vornehmen

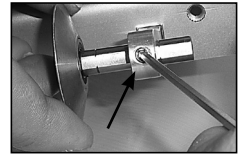
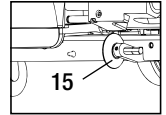
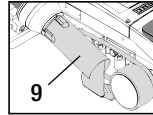

- Heissluftschweissautomat fährt von der Naht weg (Überlappschweissen)
 - Spurfineinstellung der **Lenkrolle (14)** wie folgt vornehmen:
 - **Schweissdüse (9)** abkühlen (Seite 13, 1. Arbeitsmodus, 1.8 Abkühlen)
 - **Hauptschalter (3)** ausschalten OFF 
 - Netzanschlussleitung vom elektrischen Netz trennen 
 - **Zusatzgewicht (16)** entfernen
 - Schweissautomat seitlich abkippen
 - **Arretierschraube für Spurfineinstellung (31)** lösen und **Hebel für Spurfineinstellung (32)** in die gewünschte Stellung schieben
 - **Arretierschraube für Spurfineinstellung (31)** anziehen
 - Heissluftschweissautomat in Schweissposition bringen
 - **Zusatzgewicht (16)** einlegen
 - Heissluftschweissautomat wieder in Betrieb nehmen
 - Testschweissung vornehmen

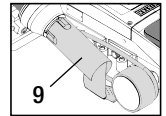
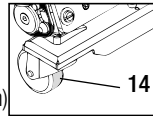

- Anfahrautomatik funktioniert nicht

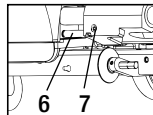
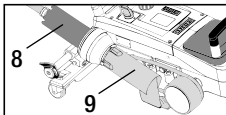

Startet der Antriebsmotor nicht automatisch nach dem Einfahren der **Schweissdüse (9)**, ist der **Anfahrssensor (6)** möglicherweise falsch eingestellt.

 - **Anfahrssensor (6)** wie folgt einstellen:
 - **Schweissdüse (9)** abkühlen (Seite 13, 1. Arbeitsmodus, 1.8 Abkühlen)
 - **Hauptschalter (3)** ausschalten OFF 
 - Mittels **Heissluftgebläse (8)** die **Schweissdüse (9)** in Schweissposition schwenken und einrasten.
 - **Einstellung des Anfahrssensors (6)** am **Gewindestift (7)** mit Inbusschlüssel vornehmen; **WICHTIG: Schaltabstand 0.2 – 0.5 mm**
 - Funktion überprüfen

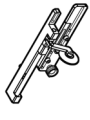

Startet der Antriebsmotor noch immer nicht automatisch, ist die Service-Stelle zu kontaktieren.

Schweissanwendungen

	Überlapp	Saum	Hohlraum (bis 70mm)	Kederschnur	Vorgefertigter Keder
 Standard- Ausführung	●	●	●		
 Saum- / Keder- Anbauteil		●	●	●	
 Niederhalter		●		●	●
 Kederführung				●	●

Anwendung

Anstelle der Führungsrolle (15) kann auch mit dem Saum- / Keder-Anbauteil gearbeitet werden.

Auch mit Standardausführung und Fixierung der Plane möglich.

Auch mit Standardausführung und Fixierung der Plane möglich.

Unterlage mit Längsrunut für Keder wird empfohlen.

Faltenfreie Fixierung der vorgefertigten Keder.

Typ

Gute Fixierung der Plane.

Markierung der Saumüberlappung für bessere Führungskontrolle.

Markierung der Saumüberlappung für bessere Führungskontrolle.

Markierung der Saumüberlappung für bessere Führungskontrolle.

Gerät frei laufen lassen, manuelle Führung der Plane mit Keder

Ausführungen Leister VARIANT T1

Artikel Nr. 141.891 VARIANT T1, 230 V / 40 mm Schweissdüse / mit Euro Stecker

Artikel Nr. 141.892 VARIANT T1, 230 V / 20 mm Schweissdüse / mit Euro Stecker

Artikel Nr. 141.893 VARIANT T1, 400 V / 40 mm Schweissdüse / mit CEE Stecker (3LNPE)

Artikel Nr. 141.894 VARIANT T1, 400 V / 20 mm Schweissdüse / mit CEE Stecker (3LNPE)

Artikel Nr. 147.739 VARIANT T1, 200 V / 40 mm Schweissdüse / ohne Stecker

Artikel Nr. 147.748 VARIANT T1, 200 V / 20 mm Schweissdüse / ohne Stecker

Zubehör

Es darf nur Leister-Zubehör verwendet werden.

Artikel Nr. 142.650 Saum- / Kederkit komplett

Artikel Nr. 140.530 Saum- / Keder-Anbauteil

Artikel Nr. 142.221 Niederhalter

Artikel Nr. 141.326 Kederführung

Artikel Nr. 139.438 Zusatzgewicht

Artikel Nr. 137.843 T-Griff Führungsstab Oberteil

Artikel Nr. 116.798 Messingbürste

Artikel Nr. 142.705 Gerätekoffer

Schulung

- Leister Technologies AG und deren autorisierte Service-Stellen bieten kostenlos Schweisskurse und Einschulungen an. Informationen unter www.leister.com.

Wartung

- Der Lufteinlass beim **Heissluftgebläse (8)** ist bei Verschmutzung mit einem Pinsel zu reinigen.
- **Schweissdüse (9)** mit Messingbürste reinigen.
- **Netzanschlussleitung (1)** und Stecker auf elektrische und mechanische Beschädigungen überprüfen.



Service und Reparatur

- Erreicht der Antriebszähler 400h bzw. der Gebläsezähler 2000h, erscheint auf dem **Display (5)** beim nächsten Einschalten des **Hauptschalters (3)** die Meldung «**Maintenance servicing**». Diese Meldung wird 10 Sekunden angezeigt und kann nicht durch **Bedienelemente (4)** übersprungen werden.
- Reparaturen sind ausschliesslich von autorisierten **Leister-Service-Stellen** ausführen zu lassen. Diese gewährleisten **innert 24 Stunden** einen fachgerechten und zuverlässigen **Reparatur-Service** mit Original-Ersatzteilen gemäss Schaltplänen und Ersatzteillisten.



Gewährleistung

- Für dieses Gerät gelten die vom direkten Vertriebspartner/Verkäufer gewährten Garantie- oder Gewährleistungsrechte ab Kaufdatum. Bei einem Garantie- oder Gewährleistungsanspruch (Nachweis durch Rechnung oder Lieferschein) werden Herstellungs- oder Verarbeitungsfehler vom Vertriebspartner durch Ersatzlieferung oder Reparatur beseitigt. Heizelemente sind von der Gewährleistung oder Garantie ausgeschlossen.
- Weitere Garantie- oder Gewährleistungsansprüche werden im Rahmen des zwingenden Rechts ausgeschlossen.
- Schäden, die auf natürliche Abnutzung, Überlastung oder unsachgemässe Behandlung zurückzuführen sind, werden von der Gewährleistung ausgeschlossen.
- Keine Garantie- oder Gewährleistungsansprüche bestehen bei Geräten, die vom Käufer umgebaut oder verändert wurden.



Congratulations on your purchase of a hot-air welding machine VARIANT T1

You have opted for a first-class hot-air welding machine made of high-quality materials. This device has been developed and manufactured in accordance with the latest welding technologies. Every VARIANT T1 undergoes stringent quality checks before leaving the factory in Switzerland.

Table of Contents

Application, Warning, Caution	Page	21
Conformity, Disposal, Technical Data	Page	22
Device Description, Controls	Page	23
Info Icons, Active Icons, Quick Info	Page	24
Operational Availability, Device Positioning	Page	25
Welding Workflow	Page	26
Transport Readiness, Button Combinations	Page	27
Work Mode (Section 1)		
1.1 Setpoint Value Display		
1.2 Work Display	Page	28
1.3 Setting the Drive Speed		
1.4 Setting the Welding Temperature	Page	29
1.5 Setting the Air Volume		
1.6 Length Measurement, Blower and Drive Counter	Page	30
1.7 Selecting Profiles		
1.8 Cooling	Page	31
1.9 Standby		
1.10 Error Messages		
Profile Setup (Section 2)		
2.1 Profile Setup Button Combination	Page	32
2.2 Creating Profiles		
2.3 Standby Setup	Page	33
FAQ	Page	34/35
Welding Applications	Page	36
Versions, Accessories, Training, Maintenance, Service and Repair, Guarantee	Page	37



Read the operating instructions carefully before starting the device and keep them for future reference.

Leister VARIANT T1 Hot-air welding machine

Application

The device should be used only in well-ventilated rooms. If necessary, work should be carried out with a fume hood or personal protective equipment. Take care to ensure that no material burns during the welding process. Check with the materials manufacturer regarding additives hazardous to health. The statutory regulations regarding health protection of the respective country are to be applied.

- Handheld hot-air welding machine for overlap, hem and piping welding of tarpaulin material (PVC and similar materials).
- **Processing only in well ventilated rooms**



Warning



Danger of death when opening the device, as live parts and connections are exposed. Remove the plug from the socket before opening the device.



Risk of fire and explosion if hot-air welding devices are used incorrectly, especially in the vicinity of flammable materials and explosive gases.



Danger – can cause burns! Do not touch the welding nozzle while it is hot. Allow the device to cool. Do not direct hot-air stream towards people or animals.



Connect device to **power socket with protective earth conductor**. Any break in the protective earth conductor inside or outside the device is dangerous!
Only use extension cables with protective earth conductor!



Caution



Rated voltage stated on the device must correspond to line/mains voltage. N 61000-3-11; $Z_{max} = 0.164 \Omega + j 0.102 \Omega$. If necessary, consultate supply authority.
Move out hot-air blower upon **mains failure**.



When using the device on building sites, a **residual current circuit breaker** is essential for the safety of persons there.



The device **must not be left unattended** when in use. Heat can reach combustible materials which are out of sight. The device may only be used by **trained personnel** or under their supervision. Children may not use the device under any circumstances.



Keep **away from wet and damp areas**.



Device must not be lifted at additional weight.

Conformity

EU Declaration of Conformity

Leister Technologies AG, Galileo-Strasse 10, CH-6056 Kaegiswil/Switzerland confirms that this product in the version put into circulation by us, fulfils the requirements of the following EU directives.

Directives: 2006/42/EC, 2014/30/EU, 2011/65/EU
 Harmonised standards: EN ISO 12100, EN 55014-1, EN 55014-2, EN 61000-3-2, EN 61000-3-3, EN 61000-3-11 (Z_{max}), EN 61000-6-2, EN 62233, EN 60335-1, EN 60335-2-45, EN IEC 63000

Kaegiswil, 11/05/2020

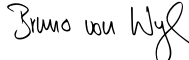
 Bruno von Wyl, CTO



 Christoph Baumgartner, GM

UK Declaration of Conformity

Leister Technologies AG, Galileo-Strasse 10, 6056 Kaegiswil, Switzerland confirms that this product in the version put into circulation by us, fulfils the requirements of the following UK Statutory Instruments.

UK Statutory Instruments: 2008 No. 1597, 2016 No. 1091, 2012 No. 3032
 Designated Standards: BS EN ISO 12100, BS EN 55014-1, BS EN 55014-2, BS EN 61000-3-2, BS EN 61000-3-3, BS EN 61000-3-11, BS EN 61000-6-2, BS EN 62233, BS EN 60335-1, BS EN 60335-2-45, BS EN IEC 63000

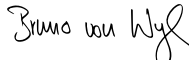
Kaegiswil, 03/31/2021

 Bruno von Wyl, CTO



 Christoph Baumgartner, GM

Disposal



Electrical equipment, accessories and packaging should be recycled in an environmentally friendly way. Do not dispose of electrical equipment with household refuse!

Technical Data

Voltage	V~	200	230	400 (2LNPE)	V~	200	230	400 (2LNPE)
Power consumption	W	4200	3680	5700	W	4200	3680	5700
Frequency	Hz	50 / 60			Hz	50 / 60		
Temperature	°C	100 – 620 infinitely variable			°F	212 – 1148 infinitely variable		
Drive	m/min.	1.5 – 18 infinitely variable			ft/min	4.9 – 59.1 infinitely variable		
Air volume	%	40 – 100			%	40 – 100		
Emission level	L_{pA} (dB)	70			L_{pA} (dB)	70		
Weight	kg	22			lbs	48.5		
without power supply cord								
Dimensions L × W × H	mm	500 × 400 × 195			inch	19.7 × 15.8 × 7.7		
Conformity mark		CE				CE		
Protection class I								

Connection voltage non-switchable

The right to make technical changes is reserved

Device Description

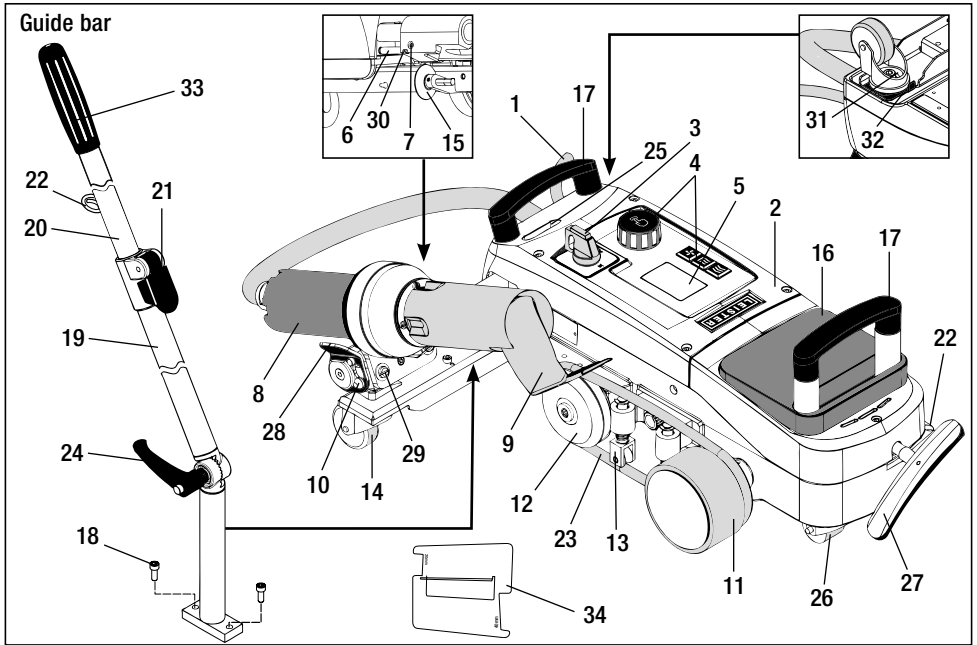

- | | | |
|-----------------------------------|-------------------------------------|--|
| 1 Power supply cord | 11 Pressure roller | 23 Round belt |
| 2 Housing | 12 Diverting roller | 24 Screw lever for guide bar bottom |
| 3 Main switch | 13 Hold-down device | 25 Swivel axis adjustment screws |
| 4 Controls | 14 Control roller | 26 Transport roller |
| 5 Display | 15 Guide roller | 27 Handle for lifting device |
| 6 Sensor | 16 Additional weight | 28 Holding handle |
| 7 Set screw for sensor setting | 17 Carrying handle | 29 Device holder angular adjustment |
| 8 Hot-air blower | 18 Cheese head screw | 30 Locking screw for welding position |
| 9 Welding nozzle | 19 Guide bar bottom | 31 Locking screw for track fine adjustment |
| 10 Locking cam for hot-air blower | 20 Guide bar top | 32 Lever for track fine adjustment |
| | 21 Clamping lever for guide bar top | 33 Guide bar handle |
| | 22 Holder for power supply cord | 34 Nozzle gauge |

Main switch (3)



For switching the hot-air welding machine VARIANT T1 On / Off

Controls (4)



e-Drive

The e-Drive serves as a navigator. It has two functions:



Turn left or right in order to set diverse menus or values



Press to confirm or to activate



Drive

Sets the drive speed



Heating

Sets the welding temperature



Blower

Sets the air volume

Info Icons

The following icons are shown on the display for information.



Welding nozzle cooling down



Device in Standby mode, device is switched off after a time



Contact authorised service centre



Indicates that the temperature is rising



Indicates that the temperature is falling

Progress bar

Active Icons

The following icons are shown on the display and activated by pressing the e-Drive .



Switch on heating and blower (if blower not yet running)



Stop the drive



Start the drive



Automatic cooling down (heating off, blower on)



Up in the structure (back to the previous programme)



Enter, confirm



Select profile



Save changed name



Change profile name



To next screen



To next screen



Reset daily distance to zero

Info Icons



Active Icons

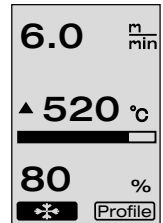
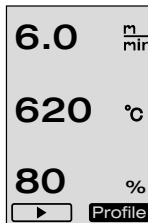
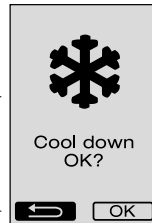
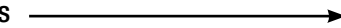

Quick Info

How do I start the hot-air welding machine VARIANT T1?

1. Establish mains connection to the electrical mains
2. **Main switch (3) ON**
3. Press Drive button → **6.0 m/min** Turn e-Drive
4. Press Heating button → **620 °C** Turn e-Drive
5. Press Blower button → **100 %** Turn e-Drive
6. Press e-Drive Heating up time approx. 1–2 minutes →
7. Carry out a test weld according to the welding instructions of the material manufacturer and national standards or directives. Check test weld.
8. Welding

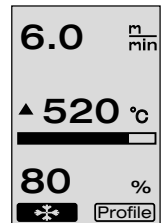

How do I switch off the hot-air welding machine VARIANT T1?

1. Press e-Drive (Fig. 1).
2. Press «Cool down OK» e-Drive and allow to cool approx. 4 minutes (Fig. 2) Blower switches off automatically.
3. After **welding nozzle (9)** has cooled down, **main switch (3) OFF**

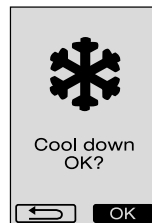

(Fig. 1)

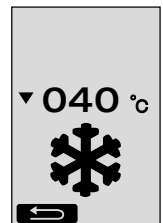

(Fig. 2)

Operational Availability

- Before putting into operation, check **power supply cord (1)** and connector as well as extension cable for electrical and mechanical damage.
- The default setting for the **welding nozzle (9)** is made at the factory.
- Check the default setting of the **welding nozzle (9)**.
 - The check can be made using the **nozzle gauge (34)** or corresponding to Detail A and B.

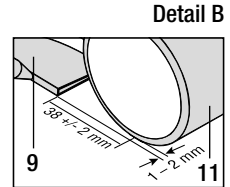
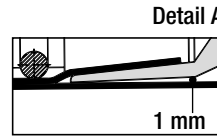
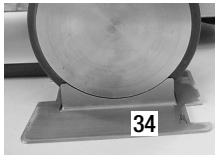

- Install **guide bar** with **cheese head screws (18)**.
 - Move the **guide bar bottom (19)** into the required position using the **screw lever (24)** and the **guide bar top (20)** using the **clamping lever (21)**.
 - Hang strain relief of **power supply cord (1)** into **holder (22)** on the guide bar or on the carriage.

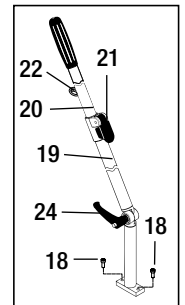

- Insert **additional weight (16)** (max. two additional weights).

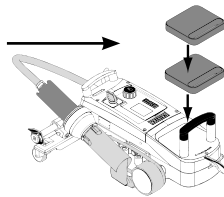

Connect device to nominal voltage. The nominal voltage indicated on the device must correspond to the mains voltage.

Move **hot-air blower (8)** out to parked position if the **mains power fails**.

Device Positioning

- The tarpaulin material must be clean between the overlap and on the upper and lower side.
- The **welding nozzle (9)**, **pressure roller (11)**, **diverting roller (12)**, **round belt (23)** and **hold-down device (13)** must be clean.
- If the hot-air welding machine is not ready for transport, lift up device using the **handle (27)** of the lifting device. The **transport rollers (26)** are now functioning.
- Move hot-air welding machine to welding position.
- Lower the hot-air welding machine into the welding position with the **handle (27)**. The **transport rollers (26)** no longer function and are thus relieved.
- Swivel **guide roller (15)** downwards.
- The **guide roller (15)** must be parallel to the **pressure roller (11)** (Detail C).

Transport readiness
Handle left

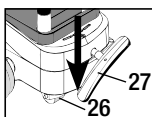

Welding position
Handle right

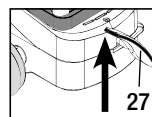

Detail C

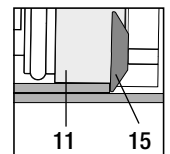

Welding Workflow

• Preparation



Carry out a test weld according to the welding instruction of the material manufacturer and national standards or guidelines. Check test weld.

- Set welding parameters for drive, heating and blower (see Section 1, Work Mode).
- Welding temperature must be reached (heating up time approx. 1–2 min.).

• Start welding

- Swivel **guide roller (15)** downwards.
- Swivel **hot-air blower (8)** gently open and in until the **locking cam (10)** is pushed out of the recess. Immediately lower the **hot-air blower (8)**.



WARNING: If the **hot-air blower (8)** is pushed in too far, the **welding nozzle (9)** and **pressure roller (11)** will come into contact. The **hot-air blower (8)** cannot then be lowered.

- Lift upper tarpaulin material slightly in the area of the guide roller and move the **welding nozzle (9)** between the overlapping tarpaulins as far as the limit stop by pushing the **hot-air blower (8)**.



- Drive motor starts automatically. No automatic start (Section FAQ, page 35).
- The machine can be started manually with the **controls (4)** Drive and e-Drive .
- If the drive is started via and e-Drive and the **welding nozzle (9)** is then pushed in, the hot-air welding machine will continue operating for about 30 cm after the **welding nozzle (9)** has been swivelled out (delayed deactivation of the drive).
- The hot-air welding machine can be guided along the overlap at the **guide bar handle (33)**, **carrying handle (17)** or **holding handle (28)**. Guide the hot-air welding machine without pressure onto the **guide bar handle (33)**, **carrying handle (17)** or **holding handle (28)** during welding. Pressure can lead to welding faults. Observe position of the **guide roller (15)**.

• End of welding

- After welding, push the **welding nozzle (9)** out from the welding position to the right using the **hot-air blower (8)** and raise.
- Push **hot-air blower (8)** to the right until the **locking cam (10)** latches into the recess of the **holding handle (28)**. The **hot-air blower (8)** is in the parked position.
- Swivel **guide roller (15)** upwards.

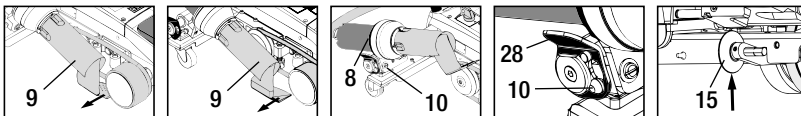

- Lowering the **transport rollers (26)** by swivelling the **handle (27)**. The **pressure roller (11)** and **diverting roller (12)** are relieved for transport in this way.

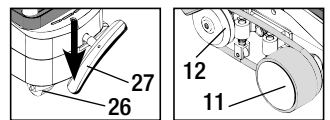

- After finishing the welding work using the e-Drive (press twice) switch off the heating; this cools down the **welding nozzle (9)** and the blower switches off automatically after approx. 4 minutes (Section 1.8, Cooling).
- Turn off main **switch (3)** OFF



Disconnect power supply cord from power supply.

- Clean **welding nozzle (9)** with brass brush.

Transport Readiness

- Swivel **guide roller (15)** upwards.
- Push **hot-air blower (8)** to the right until the **locking cam (10)** latches into the recess of the **holding handle (28)**. The **hot-air blower (8)** is in the parked position.
- Lower the **transport rollers (26)** by swivelling the **handle (27)**. The **pressure roller (11)** and **diverting roller (12)** are relieved for transport in this way.

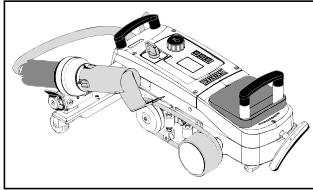
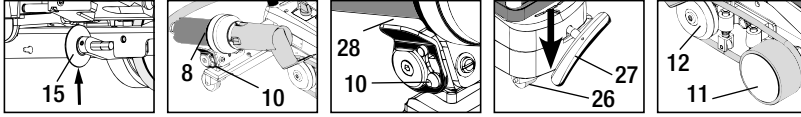

Moving

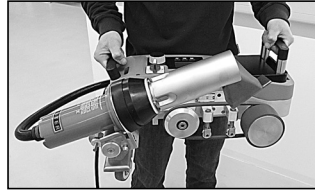

Carrying

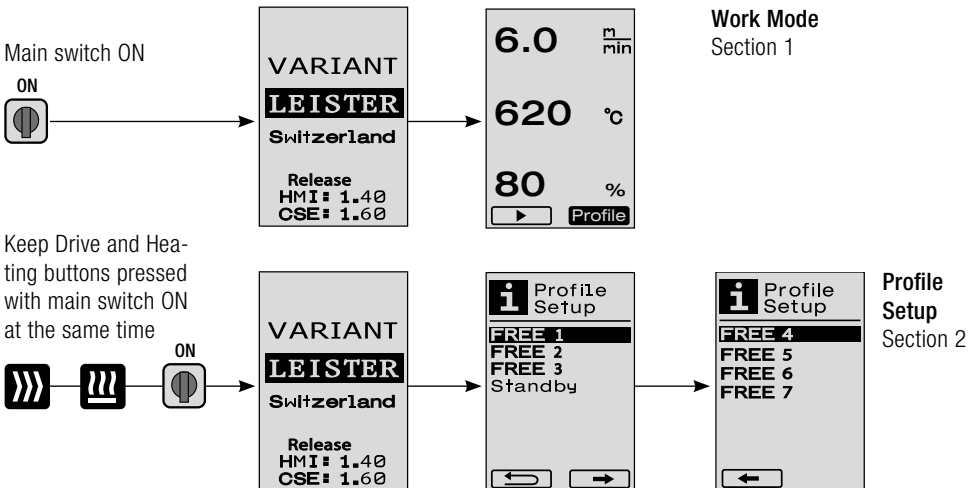

Button Combinations



1. Work Mode

1.1 Setpoint Value Display (after switching on the device)

Main switch (3) ON 

- After switching on the device, the values last set appear on the **display (5)** (Fig. 3).
- The heating, blower and drive are switched off in this menu.
- Here the user can perform all settings described in the following sections using the **controls (4)**.
- If, however, the heating element temperature is greater than 80°C when switching on, the display will immediately change to the Cool Down mode (Section 1.8 Cooling) in which the blower is always operated at full power, thus cooling down the **welding nozzle (9)**. You can change back to the Work Mode from this mode at any time by pressing the e-Drive .
- If the heating element temperature reaches 60°C during cooling, the blower will continue to operate for 2 minutes and then switch off automatically. The **display (5)** changes back to the Setpoint Value display (Fig. 3).
- Turning the e-Drive  to Profiles allows various welding profiles to be selected (Fig. 4; Section 1.7 Selecting Profiles).

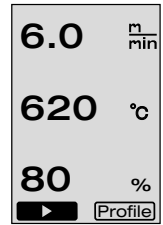

(Fig. 3)



(Fig. 4)

1.2 Work display

- Pressing the e-Drive  starts the heating and blower and the Setpoint Value display changes to the Work display.
- When the **welding nozzle (9)** is heating up, this is indicated on the **display (5)** with a progress bar, arrow ▲ (up) and the actual value of the welding temperature (flashing) (Fig. 5). Once the setpoint value of the welding temperature is reached, the arrow and progress bar will no longer be displayed (Fig. 6).
- If the mains voltage is outside (+/- 15%) the specified nominal voltage, the symbol will be displayed alternately with the measured undervoltage ⚡ / overvoltage ⚡ and the set air volume. If the air volume is 100 %, the symbol will be displayed flashing with the measured undervoltage ⚡ / overvoltage ⚡ (Fig. 7). (Only possible with VARIANT T1 230V~).

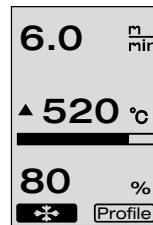

(Fig. 5)

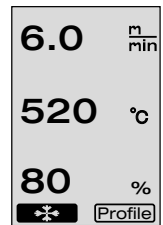

(Fig. 6)

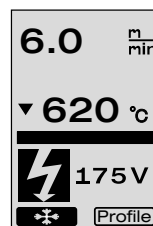

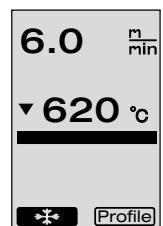

(Fig. 7)



(Fig. 8)













Undervoltage/Overvoltage can affect the welding results!

- If no button is pressed after a definite time (**welding nozzle (9)** NOT in welding position), the Standby menu will be displayed (Section 1.9 Standby).
- If the **welding nozzle (9)** is in the parked position, the menus Cool Down (Section 1.8 Cooling) or Profiles (Section 1.7 Selecting Profiles) can be selected by turning the e-Drive .
- If the **welding nozzle (9)** is swivelled in, the two menu items  **Profile** will disappear on the **display (5)** and can no longer be selected.
- While the **welding nozzle (9)** is cooling down, this is indicated with a filled out progress bar, arrow ▼ (down) and flashing actual value of the welding temperature on the **display (5)** (Fig. 8).

1. Work Mode





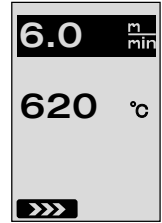

1.3 Setting the drive speed

- The drive speed can be adapted with the Drive  button. This can be set by turning the e-Drive  in 0.1 m/min. increments from 1.5 m/min. to 18.0 m/min. This setting can be carried out with the drive switched on or switched off. If no entry is made by the **controls (4)** within 3 seconds, the new drive speed will be accepted. The Setpoint Value display or Cool Down menu appears on the **display (5)** (Fig. 9).
- If the **welding nozzle (9)** is not in the welding position, the (Start)  symbol will appear at the bottom left of the **display (5)**.
- The drive can be switched on by pressing the e-Drive  after which the (Stop)  symbol will appear. The drive speed can be adjusted directly by turning the e-Drive .
- Pressing the e-Drive  again executes the Stop command, which switches off the drive. The Setpoint Value display or Cool Down menu appears on the display.
- If the Drive  button is pressed for 3 seconds, the display will change to another menu (see Section 1.6 Length Measurement, Blower and Drive Counter).
- You can change to the relevant menu by pressing the Heating  or Blower  button.



(Fig. 9)

1.4 Setting the welding temperature

- The welding temperature can be changed with the Heating  button. The welding temperature can be set in 10°C increments from 100°C to 620°C by turning the e-Drive . The setting is accepted after 3 seconds, as long as no button is pressed within these 3 seconds (Fig. 10).
- If this menu is called up from the Setpoint Value display, the heating and blower can be started by pressing the e-Drive . Once the heating is switched on, the Cool Down menu can be selected (Section 1.8 Cooling) (Fig. 11).
- If the Heating  button is pressed for 3 seconds, the mains voltage will appear below the drive speed. This call-up is only possible from the Work display (Section 1.2). (Only possible with VARIANT T1 230V~).
- You can change to the relevant menu by pressing the Drive  or Blower  button.

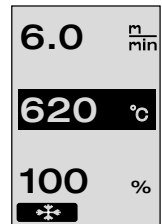



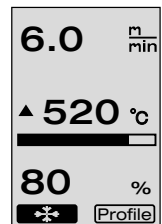



(Fig. 10)



(Fig. 11)

1. Work Mode



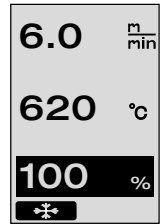

1.5 Setting the air volume

- The air volume can be changed with the Blower  button. The air volume can be set in 5% increments from 40% to 100% by turning the e-Drive . The setting is accepted after 3 seconds, as long as no button is pressed within these 3 seconds. If the air volume is set to 100%, no information will appear on the **display (5)** (Fig. 12).
- If this menu is called up from the Setpoint Value display, the heating and blower can be started by pressing the e-Drive .
- The Cool Down menu can be selected by pressing the e-Drive .
- You can change to the relevant menu using the Drive  or Heating  button.



(Fig. 12)

1.6 Length Measurement, Blower and Drive Counter



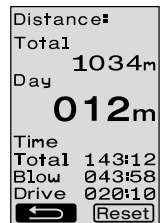







- This menu (Fig. 13) appears if the Drive  button is pressed for at least 3 seconds.
- The menu displays all operating times and the distance which the device has travelled since being switched on. The total distance (here: 1034 m) cannot be changed and shows the entire path taken since being put into operation.
- The daily distance (here: 012 m) is not reset automatically, but instead can be reset to zero by the user via **Reset** by pressing the e-Drive .
- The Time values concern the operating time for the individual components of the device. The time is assigned to the blower «Blow» (here: 043:58) and the drive «Drive» (here: 020:10). The «Total» time refers to the operating time. It counts the hours and minutes (here: 143:12) during which the **main switch (3)** is switched on.
- If the Back arrow  is selected by pressing the e-Drive , you will be taken back to the menu from which the Drive  button has been pressed.



(Fig. 13)

1. Work Mode

1.7 Selecting Profiles

- If the display **Profile** at the right bottom of the **display (5)** is activated, profiles can be loaded by pressing the e-Drive . The display «Select Profile» then appears. A profile can be selected by turning the e-Drive . The profiles FREE 1–7 and 3 can be defined by users themselves (see Section 2 Profile Setup). All other profiles have permanently assigned values and cannot be defined by the user (Fig. 14).
- Turning the e-Drive  activates left or right arrows on the **display (5)** at the bottom.
Right arrow  by pressing the e-Drive  to the next page (Fig. 15).
Left arrow  by pressing the e-Drive  to the previous page (Fig. 16).
- If the Back arrow  is activated by turning the e-Drive , you will be taken back to the menu from which the Profiles menu has been selected by pressing the e-Drive  (Fig. 15).

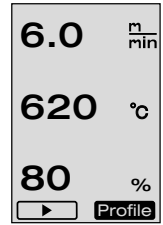

(Fig. 14)

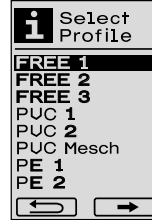

(Fig. 15)

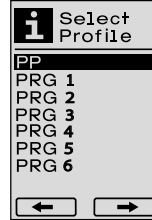



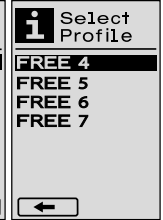



(Fig. 16)



Carry out a test weld according to the welding instruction of the material manufacturer and national standards or guidelines. Check test weld.

1.8 Cooling

- If the symbol  is selected by pressing the e-Drive  (Fig. 17), the menu «Cool down OK?» will appear (Fig. 18). Pressing the e-Drive  activates the symbol OK at the right bottom of the **display (5)**. This initiates the cooling process.
- During the cooling down process, the air volume is increased to 100% and the instantaneous welding temperature displayed (Fig. 19).
If the welding temperature of 60°C is fallen below, the blower will continue to operate for 2 minutes and will automatically switch off after this time expires.
The display changes to the Setpoint Value display.
- If the e-Drive  is pressed during the cooling process, the heating will start and the Work Display will appear on the **display (5)** (see Section 1.2 Work Display).
- If the Cool Down menu is active, the drive can be switched on/off manually via the Drive  button.
The Heating  and Blower  buttons do not have any function.

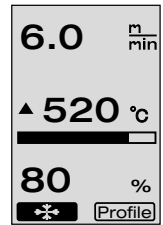

(Fig. 17)



(Fig. 18)



(Fig. 19)

1. Work Mode

1.9 Standby

- If the **welding nozzle (9)** is not in the welding position and no button is pressed during a standby time defined by the user, Cool Down mode will automatically start after the countdown has passed (Fig. 20). The cooling down process is initiated.
- If the e-Drive  is pressed before the countdown has passed (180 seconds), the **display (5)** will change to Work Display (see Section 1.2 Work Display).
- Setting the standby time (Section 2.3 Standby Setup).

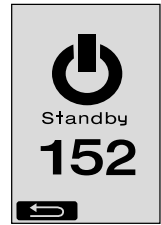

(Fig. 20)

1.10 Error messages

- If a malfunction occurs in the hot-air welding machine VARIANT T1, a message accompanied by an error code will appear on the **display (5)**. This code stands for a more precise definition of the error which can be seen in the list below.
- Separate symbols are displayed for error 02 and error 40.
- In case of all other errors, the spanner is displayed for the service prompt.



Error	Type of error
Err00	Control electronics defective
Err01	Interruption or short-circuit of the temperature probe
Err02	Heating element / Electronics defective (interruption in one/both winding(s))
Err04	Triac defective (one or both Triacs are defective)
Err08	Blower motor defective
Err40	Undervoltage 25% (mains voltage 75%) only VARIANT T1 230 V~

2. Profile Setup





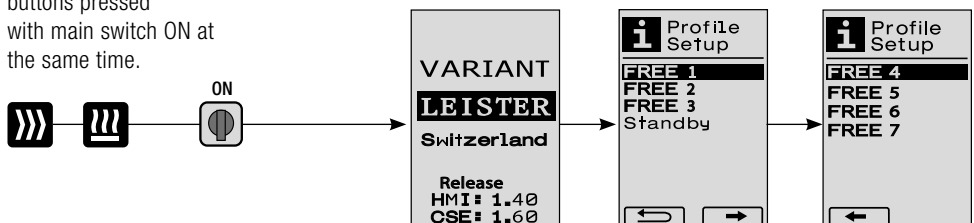





















2.1 Profile Setup Button Combination

Keep Drive and Heating buttons pressed with main switch ON at the same time.



2. Profile Setup

2.2 Creating Profiles

- The Profile Setup allows you to create 7 individual profiles for which the name, and all three parameters Drive , Heating , Blower  can be freely set and then saved by pressing the e-Drive  (Fig. 21).
- The various menu items can be selected using the **controls (4)**. Pressing the e-Drive  will take you back to the Profile Setup selection.
- Turning the e-Drive  activates left or right arrows on the **display (5)** at the bottom.
Right arrow  by pressing the e-Drive  to the next page (Fig. 15).
Left arrow  by pressing the e-Drive  to the previous page (Fig. 16).
- If the ABC  symbol is activated by turning the e-Drive , you will be taken back to the menu Profile Name by pressing the e-Drive .
- In the Profile Name menu, you can turn the e-Drive  to select the characters **_ / . / A to Z / 0 to 9**, as well as the left or right arrows and the symbols **Save**  or **Back** .
- Change profile name
 - If you turn the e-Drive  you can select the left or right arrows. If the right arrow is selected by pressing the e-Drive , the position in the profile name will jump one character (black) to the right. If you activate the left arrow by pressing the e-Drive , the position in the profile name will jump one character (black) to the left (Fig 23).
 - Turning the e-Drive  allows the required character (**_ / . / A to Z / 0 to 9**) to be selected. If you press the e-Drive  the character shown black in the profile name will now be replaced by the character previous selected.
- Save or reject profile name
 - If the **Save**  symbol is selected by turning the e-Drive , the profile name will be saved by pressing the e-Drive .
 - If the **Back**  symbol is selected by turning the e-Drive , the profile name will be rejected (not saved) by pressing the e-Drive .

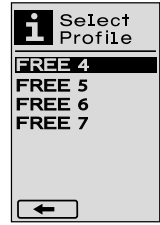

(Fig. 21)

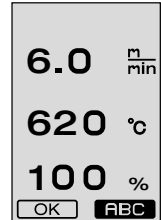

(Fig. 22)





(Fig. 23)



Carry out a test weld according to the welding instructions of the material manufacturer and national standards or directives. Check test weld.

2.3 Standby Setup

- The standby times defines the time that has to pass (no buttons pressed, **welding nozzle (9)** not in welding position) before the cooling process (see Section 1.8 Cooling) is automatically triggered.
 - Turning the e-Drive  allows the time to be set from 5 to 120 minutes. 40 minutes are set at the factory.
- Pressing the e-Drive  will take you back to the Profile Setup selection.



- Machine switches off automatically
 - The machine is automatically switched off after a set time with Standby mode (factory setting 40 minutes).
 - If needed, increase standby time (Page 33, 2. Profile Setup, 2.3 Standby Setup).
- Quality of the weld is defective
 - Check drive speed, welding temperature and air volume
 - Clean **welding nozzle (9)** with wire brush
 - **Welding nozzle (9)** is set incorrectly

Carry out the adjustment of the welding nozzle (9) as follows

- Allow **welding nozzle (9)** to cool down (Page 31, 1. Work Mode, 1.8 Cooling).
- Loosen hexagon screws on device holder.
- Carry out angular adjustment via swivel movements at **hot-air blower (8)**.
- The **welding nozzle (9)** must (arrow L) be located on the **nozzle gauge (34)** and (arrow R) on the substrate.
- Tighten hexagon screws on device holder.
- Move **nozzle gauge (34)** to position. Note scale on **nozzle gauge (34)**.
- Move **hot-air blower (8)** into welding position.
- Loosen **swivel axis adjustment screws (25)**.
- Align **hot-air blower (8)** parallel to **nozzle gauge (34)**.
- Tighten **swivel axis adjustment screws (25)**.
- Remove **nozzle gauge (34)** and perform test weld.

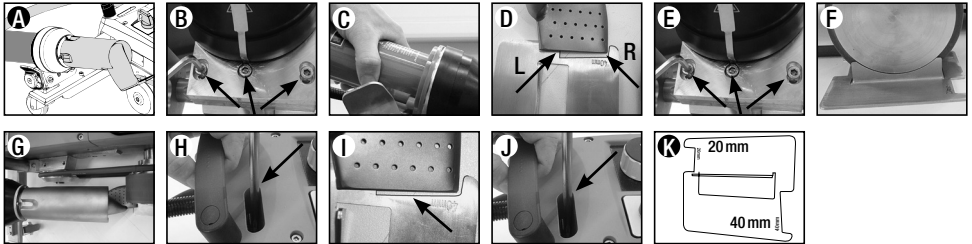

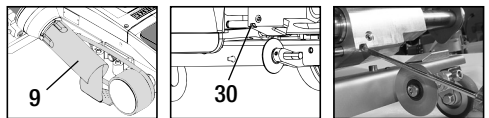

- Failure to reach the set temperature (temperature display flashes)
 - Check mains voltage
 - Reduce air volume
 - Reduce temperature
- Hot-air blower does not lock into welding position
 - The ball pressure element must be set as follows:
 - Allow **welding nozzle (9)** to cool (Page 31, 1. Work Mode, 1.8 Cooling)
 - Move **welding nozzle (9)** into welding position
 - Tighten **screw (30)** slightly with a screwdriver, then turn **screw (30)** back approx. 1/2 revolution.

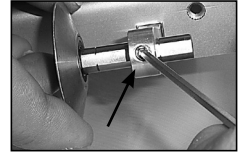
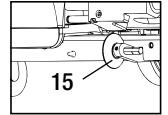
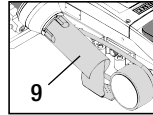

- Weld seam width is not constant
 - Carry out fine adjustment of the guide roller as follows:
 - Allow **welding nozzle (9)** to cool
 - Move **welding nozzle (9)** into welding position
 - Loosen hexagon screw of the **guide roller (15)**
 - Push **guide roller (15)** into the required position
 - Tighten hexagon screw
 - Perform test weld



- Hot-air welding machine moves away from the weld (overlap welding)
 - Carry out track fine adjustment of the **control roller (14)** as follows:
 - Allow **welding nozzle (9)** to cool (Page 31, 1. Work Mode, 1.8 Cooling)
 - Turn off **main switch (3)** 
 - Disconnect power supply cord from power supply 
 - Remove **additional weight (16)**
 - Tilt welding machine to the side
 - Loosen **locking screw for track fine adjustment (31)** and push **lever for track fine adjustment (32)** into the required position
 - Tighten **locking screw for track fine adjustment (31)**
 - Move hot-air welding machine into welding position
 - Insert **additional weight (16)**
 - Restart hot-air welding machine
 - Perform test weld

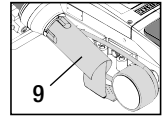
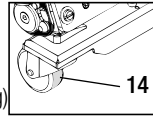



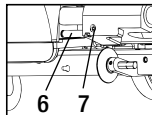
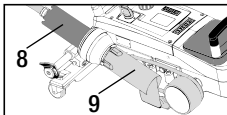

- Startup mechanism not working

If the drive motor does not start automatically after moving in the **welding nozzle (9)**, the **sensor (6)** is possibly set incorrectly.

- Set **sensor (6)** as follows:
 - Allow **welding nozzle (9)** to cool (Page 31, 1. Work Mode, 1.8 Cooling)
 - Turn off **main switch (3)** 
 - Using the **hot-air blower (8)**, swivel the **welding nozzle (9)** into the welding position and latch in.
 - Carry out setting for the **sensor (6)** at **set screw (7)** with Allen key;
 - IMPORTANT: Sensing distance 0.2 – 0.5mm**
 - Check function



If the drive motor still does not start automatically, the service centre must be contacted.

	Overlap	Hem	Hemstitch (up to 70 mm)	Piping cord	prefabricated piping
 <p>Standard version</p>	●	●	●		
 <p>Hem/Piping add-on part</p>		●	●	●	
 <p>Hold-down device</p>		●		●	●
 <p>Piping guide</p>				●	●

Application

Instead of the guide roller (15) you can also work with the hem/piping add-on part.

Also possible with standard version and fixing of the tarpaulin.

Also possible with standard version and fixing of the tarpaulin.

A base with longitudinal groove is recommended.

Crease-free fixing of the prefabricated piping.

Type

Good fixing of the tarpaulin.

Marking the hem overlap for better guide control.

Marking the hem overlap for better guide control.

Marking the hem overlap for better guide control. Allow device to run freely, manual guiding of the tarpaulin with piping.

Leister VARIANT T1 Versions

Article no. 141.891 VARIANT T1, 230 V / 40 mm welding nozzle / with European plug

Article no. 141.892 VARIANT T1, 230 V / 20 mm welding nozzle / with European plug

Article no. 141.893 VARIANT T1, 400 V / 40 mm welding nozzle / with CEE plug (3LNPE)

Article no. 141.894 VARIANT T1, 400 V / 20 mm welding nozzle / with CEE plug (3LNPE)

Article no. 147.739 VARIANT T1, 200 V / 40 mm welding nozzle / without plug

Article no. 147.748 VARIANT T1, 200 V / 20 mm welding nozzle / without plug

Accessories

For safety and technical reasons, only Leister accessories may be used.

Article no. 142.650 Hem / Piping kit complete

Article no. 140.530 Hem / Piping add-on part

Article no. 142.221 Hold-down device

Article no. 141.326 Piping guide

Article no. 139.438 Additional weight

Article no. 137.843 T-handle for guide bar top

Article no. 116.798 Brass brush

Article no. 142.705 Carrying case

Training

- Leister Technologies AG and its authorised service points offer free welding courses and training events. Information at www.leister.com.

Maintenance

- The air inlet on the **hot-air blower (8)** must be cleaned with a brush if soiled.
- Clean **welding nozzle (9)** with brass brush.
- Check **power supply cord (1)** and plug for electrical and mechanical damage.



Service and Repairs

- If the drive counter reaches 400 h or the blower counter reaches 2000 h, the message «**Maintenance servicing**» will appear on the **display (5)** the next time the **main switch (3)** is switched on. This message is displayed for 10 seconds and cannot be skipped by the **controls (4)**.
- Repairs should only be carried out by authorised **Leister service centres**. These guarantee a professional, reliable **repair service within 24 hours**, using original replacement parts according to the circuit diagrams and replacement part lists.

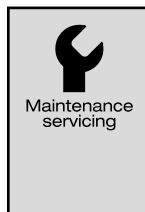

Guarantee

- For this tool, the guarantee or warranty rights granted by the relevant distributor/seller shall apply. In case of guarantee or warranty claims any manufacturing or workmanship defects will either be repaired or replaced by the distributor at its discretion. Warranty or guarantee rights have to be verified by an invoice or a delivery document. Heating elements shall be excluded from warranty or guarantee.
- Additional guarantee or warranty claims shall be excluded, subject to mandatory provisions of law.
- Warranty or guarantee shall not apply to defects caused by normal wear and tear, overload or improper handling.
- Warranty or guarantee claims will be rejected for tools that have been altered or changed by the purchaser.

Leister si congratula per l'acquisto della saldatrice automatica ad aria calda VARIMAT T1,

una saldatrice automatica d'eccellenza prodotta con materiali di alta qualità.

Questo apparecchio è stato sviluppato e prodotto sulla base delle più avanzate tecnologie nel campo della saldatura. Prima di uscire dallo stabilimento in Svizzera, tutti i modelli di VARIANT T1 sono sottoposti a un rigoroso controllo di qualità.

Indice

Modalità d'impiego, avvertenze, cautela	pagina	39
Conformità, smaltimento, specifiche tecniche	pagina	40
Descrizione dell'apparecchio, comandi	pagina	41
Icone di informazione, icone attive, informazioni rapide	pagina	42
Possibilità d'impiego, posizionamento dell'apparecchio	pagina	43
Processo di saldatura	pagina	44/45
Apparecchio pronto al trasporto, combinazioni di pulsanti	pagina	45
Modalità operativa (capitolo 1)		
1.1 Visualizzazione del valore nominale		
1.2 Visualizzazione operativa	pagina	46
1.3 Impostazione della velocità del motore		
1.4 Impostazione della temperatura di saldatura	pagina	47
1.5 Impostazione della portata d'aria		
1.6 Misurazione della lunghezza, contatore della ventola e del motore	pagina	48
1.7 Selezione di PROFILE		
1.8 Raffreddamento	pagina	49
1.9 Stand-by		
1.10 Messaggi d'errore		
PROFILE SETUP (capitolo 2)		
2.1 Combinazione di pulsanti	pagina	50
2.2 Creazione dei profili		
2.3 STAND-BY SETUP	pagina	51
FAQ	pagina	52/53
Applicazioni della saldatura	pagina	54
Versione, accessori, formazione, manutenzione, servizio di assistenza e riparazione, garanzia	pagina	55



Prima dell'attivazione leggere con attenzione le istruzioni d'uso e conservarle per ulteriori consultazioni.

VARIANT T1 Leister

Saldatrice automatica ad aria calda

Modalità d'impiego

L'apparecchio è progettato per essere utilizzato esclusivamente all'interno di locali ben aerati. Ove necessario, durante le fasi operative è richiesto l'impiego di impianti di aspirazione o di dispositivi di protezione individuale. Prestare attenzione a non bruciare il materiale durante il processo di saldatura. Verificare con il produttore del materiale l'eventuale presenza di additivi nocivi per la salute. Si applicano le disposizioni normative relative alla protezione della salute del Paese in cui viene utilizzato il prodotto.

- Saldatrice automatica ad aria calda a controllo manuale per punti di saldatura a sovrapposizione, di orlatura e di rinforzo di materiale per teloni (PVC e simili).
- **Lavorazione possibile solo in locali dotati di una buona ventilazione**



Avvertenze



Aperto l'apparecchio è presente il **pericolo di morte** perché vengono esposti componenti e collegamenti sotto tensione. Estrarre la spina elettrica prima di procedere all'apertura dell'apparecchio.



È presente il **pericolo di incendio e di esplosione** in caso di utilizzo non conforme degli apparecchi ad aria calda, in particolare nelle vicinanze di materiali infiammabili e gas esplosivi.



Pericolo di ustione: non toccare l'ugello di saldatura quando è ancora caldo. Lasciar raffreddare l'apparecchio. Non orientare il getto di aria calda verso persone o animali.



Collegare l'apparecchio ad una **presa di corrente dotata di conduttore di terra**. Tutte le interruzioni del conduttore di terra all'interno o all'esterno dell'apparecchio sono pericolose. **Utilizzare esclusivamente cavi di prolunga dotati di conduttore di terra.**



Cautela



La **tensione nominale** indicata sull'apparecchio deve corrispondere alla tensione di rete. EN 61000-3-11; $Z_{max} = 0.0.164 \Omega + j 0.102 \Omega$. Se necessario consulti le aziende di utilità elettriche. In caso di **black-out** disattivare la soffiante dell'aria calda.



Se si utilizza l'apparecchio in cantiere, sono tassativamente necessari gli **interuttori per correnti di guasto** per garantire la tutela del personale.



È necessario **mantenere l'apparecchio sotto controllo** durante il funzionamento. Il calore può raggiungere materiali infiammabili che si trovano fuori dal campo visivo. L'impiego dell'apparecchio è consentito esclusivamente a **personale specializzato** o sotto il monitoraggio di quest'ultimo. È tassativamente vietato l'impiego da parte dei bambini.



Proteggere l'apparecchio da umidità e da ambienti bagnati.



Non è consentito sollevare l'apparecchio facendo presa sul peso supplementare.

Conformità

Leister Technologies AG, Galileo-Strasse 10, CH-6056 Kaegiswil/Svizzera dichiara che il presente prodotto, nella versione introdotta sul mercato, soddisfa i requisiti delle direttive CE riportate di seguito.

Direttive: 2006/42/EC, 2014/30/EU, 2011/65/EU
Normative armonizzate: EN ISO 12100, EN 55014-1, EN 55014-2, EN 61000-3-2, EN 61000-3-3, EN 61000-3-11 (Z_{max}), EN 61000-6-2, EN 62233, EN 60335-1, EN 60335-2-45, EN IEC 63000

Kaegiswil, 05.11.2020

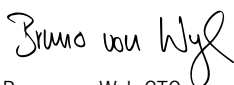

Bruno von Wyl, CTO







Christoph Baumgartner, GM

Smaltimento



Gli apparecchiature elettriche, gli accessori e gli imballaggi devono essere riciclati nel rispetto dell'ambiente. Non smaltire gli apparecchiature elettriche insieme ai rifiuti domestici!

Specifiche tecniche

Tensione	V~	200	230	400 (2LNPE)	V~	200	230	400 (2LNPE)
Potenza	W	4200, 3680, 5700			W	4200, 3680, 5700		
Frequenza	Hz	50 / 60			Hz	50 / 60		
Temperatura	°C	100 – 620 con regolazione continua			°F	212 – 1148 con regolazione continua		
Motore	m/min.	1.5 – 18 con regolazione continua			ft/min	4.9 – 59.1 con regolazione continua		
Portata d'aria	%	40 – 100			%	40 – 100		
Livello delle emissioni acustiche	L_{pA} (dB)	70			L_{pA} (dB)	70		
Peso senza cavo di collegamento alla rete	kg	22			lbs	48.5		
Dimensioni L × P × H	mm	500 × 400 × 195			inch	19.7 × 15.8 × 7.7		
Marchio di conformità								
Classe di protezione I								
Tensione allacciamento non commutabile								
Con riserva di modifiche tecniche								

Descrizione dell'apparecchio

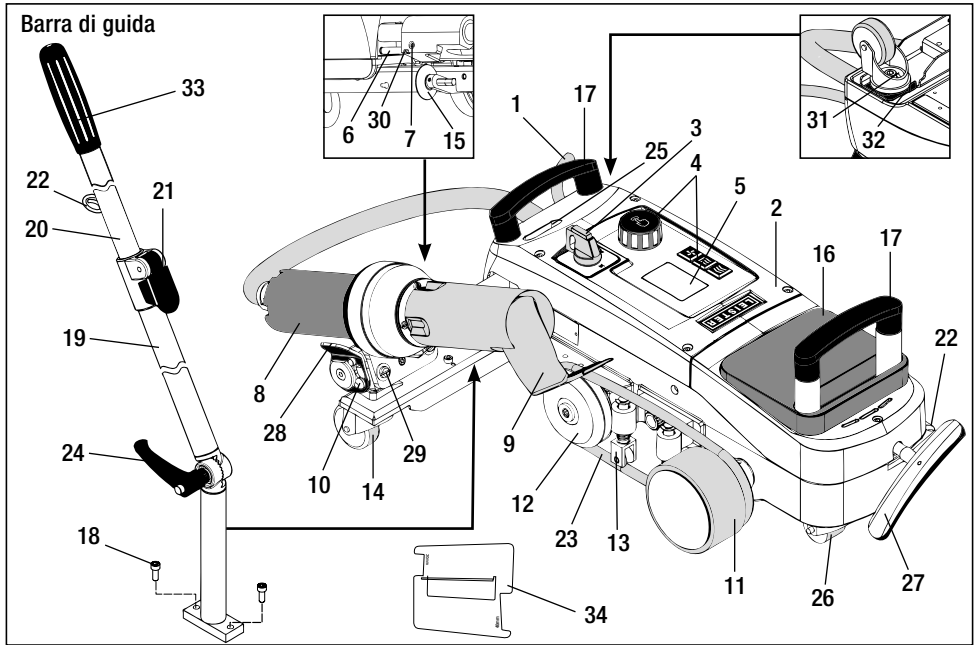

- | | | |
|---|--|--|
| 1 Cavo di collegamento alla rete | 13 Premibarra | 25 Viti di regolazione asse orientabile |
| 2 Alloggiamento | 14 Rullo orientabile | 26 Rullo di trasporto |
| 3 Interruttore principale | 15 Rullo di guida | 27 Maniglia per il dispositivo d'estrazione |
| 4 Comandi | 16 Peso supplementare | 28 Maniglia di sostegno |
| 5 Display | 17 Maniglia da trasporto | 29 Impostazione dell'angolazione supporto dell'apparecchio |
| 6 Sensore di avviamento | 18 Vite a testa cilindrica | 30 Vite d'arresto per la posizione di saldatura |
| 7 Vite filettata per l'impostazione del sensore di avviamento | 19 Parte inferiore barra di guida | 31 Vite d'arresto per l'impostazione di precisione della traccia |
| 8 Soffiante dell'aria calda | 20 Parte superiore barra di guida | 32 Leva per l'impostazione di precisione della traccia |
| 9 Ugello di saldatura | 21 Leva di serraggio | 33 Maniglia barra di guida |
| 10 Camma d'arresto per soffiante dell'aria calda | 22 Supporto per cavo di collegamento alla rete | 34 Calibro degli ugelli |
| 11 Rullo pressore | 23 Cinghia a sezione circolare | |
| 12 Rullo di rinvio | 24 Vite della leva | |
| | Parte inferiore barra di guida | |

Interruttore principale (3)



Per l'accensione / lo spegnimento della saldatrice automatica ad aria calda VARIMAT T1.

Comandi (4)



e-Drive

e-Drive funge da navigatore e svolge due funzioni:



Ruotarlo a destra o a sinistra per configurare i diversi menu e valori.



Premerlo per conferma o attivare le opzioni.



Motore

Impostazione della velocità del motore



Riscaldamento

Impostazione della temperatura di saldatura



Ventola

Impostazione della portata d'aria

Icone di informazione

Le icone riportate di seguito vengono visualizzate sul display per fornire informazioni.



Ugello di saldatura in fase di raffreddamento



Apparecchio in modalità stand-by, l'apparecchio viene disattivato al termine del ciclo



Contattare il centro di assistenza tecnica autorizzato



Indicazione della temperatura in aumento



Indicazione della temperatura in diminuzione



Barra d'avanzamento

Icone attive

Le seguenti icone vengono visualizzate sul display e confermate selezionando e-Drive .



Accensione del riscaldamento e della ventola (se la ventola non è ancora in funzione)



Arresto del motore



Avvio del motore



Raffreddamento automatico (riscaldamento OFF, ventola ON)



Un livello in alto nella struttura (indietro al programma precedente)



ENTER, conferma



Selezione di PROFILE



Memorizzazione del nome modificato



Modifica del nome PROFILE



Pagina successiva



Pagina precedente



Reset distanza giornaliera

Icone di informazione

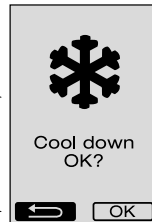
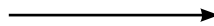

Icone attive

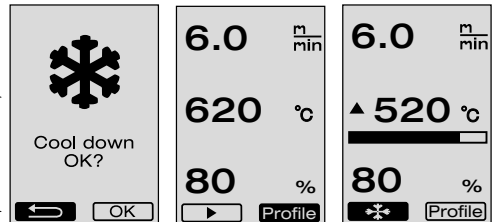
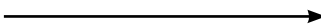

Informazioni rapide

Accensione della saldatrice automatica ad aria calda VARIANT T1

1. Collegare il cavo di collegamento alla rete elettrica .
2. Interruttore principale (3) ON .
3. Premere il pulsante motore → ruotare e-Drive .
4. Premere il pulsante riscaldamento → ruotare e-Drive .
5. Premere il pulsante ventola → ruotare e-Drive .
6. Premere e-Drive Tempo di riscaldamento 1 – 2 minuti circa → .
7. Effettuare una saldatura di prova in base alle istruzioni di saldatura del produttore del materiale e alle normative o alle direttive nazionali. Verificare la saldatura di prova.
8. Saldatura .

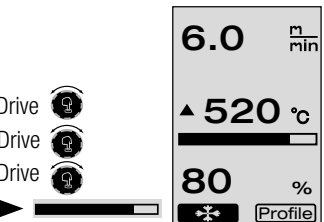

Spegnimento della saldatrice automatica ad aria calda VARIMAT T1

1. Premere e-Drive (Fig. 1).
2. «Cool down OK» premere e-Drive e lasciar raffreddare per 4 minuti circa (Fig. 2).
3. Una volta completato il raffreddamento dell'ugello di saldatura (9), interruttore principale (3) OFF .

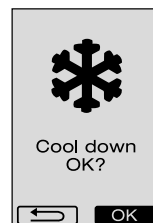

(Fig. 1)

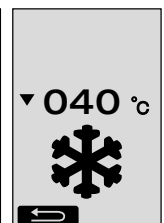

(Fig. 2)

Possibilità d'impiego

- Prima dell'attivazione controllare la presenza di guasti elettrici e meccanici nel **cavo di collegamento alla rete (1)**, nella spina elettrica e nel cavo di prolunga.
- Presso lo stabilimento viene preimpostata la configurazione base dell'**ugello di saldatura (9)**.
- Controllare l'impostazione base dell'**ugello di saldatura (9)**.
 - Il controllo è possibile con il **calibro degli ugelli (34)** o in base al dettaglio A e B.

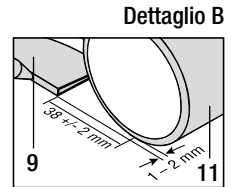
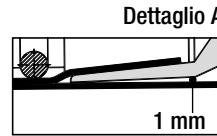
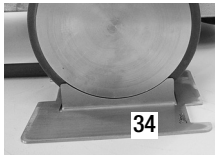

- Montare la **barra di guida (18)**.
 - Portare nella posizione desiderata la **parte inferiore barra di guida (19)** con la **vite della leva (24)** e la **parte superiore barra di guida (20)** con la **leva di serraggio (21)**.
 - Agganciare lo scarico della trazione del **cavo di collegamento alla rete (1)** presente nel **supporto (22)** sulla barra di guida o sul carrello.

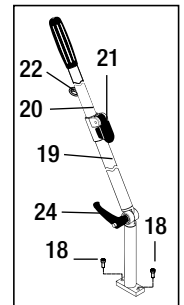

- Inserire il **peso supplementare (16)** (max. due pesi supplementari)

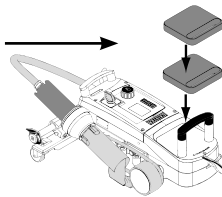

Collegare l'apparecchio alla tensione nominale. La tensione nominale specificata sull'apparecchio deve coincidere con la tensione di rete.

In caso di **black-out** disattivare la **soffiante dell'aria calda (8)**.

Posizionamento dell'apparecchio

- Il materiale per teloni deve essere pulito tra le sovrapposizioni e sul lato superiore ed inferiore.
- L'**ugello di saldatura (9)**, il **ruolo pressore (11)**, il **ruolo di rinvio (12)**, la **cinghia a sezione circolare (23)** e il **premibarra (13)** devono essere puliti.
- Se la saldatrice automatica ad aria calda non è pronta per il trasporto, sollevare l'apparecchio con la **maniglia (27)** del dispositivo d'estrazione. A questo punto i **rolli di trasporto (26)** sono in funzione.
- Portare la saldatrice automatica ad aria calda nella posizione di saldatura.
- Abbassare la saldatrice automatica ad aria calda nella posizione di saldatura con la **maniglia (27)**. I **rolli di trasporto (26)** non svolgono più nessuna funzione e sono quindi liberati dal carico.
- Orientare il **ruolo di guida (15)** verso il basso.
- Il **ruolo di guida (15)** deve risultare parallelo rispetto al **ruolo pressore (11)** (dettaglio C).

Apparecchio pronto al trasporto maniglia a sinistra

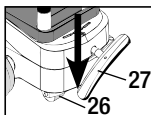

Posizione di saldatura Maniglia a destra

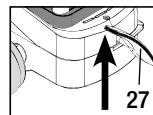

Dettaglio C

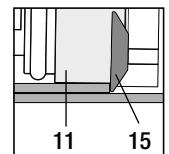

Processo di saldatura

• Preparazione



Effettuare una saldatura di prova in base alle istruzioni di saldatura del produttore del materiale e alle normative o alle direttive nazionali. Verificare la saldatura di prova.

- Impostare i parametri di saldatura motore, riscaldamento e ventola (capitolo 1, modalità operativa)
- È necessario raggiungere la temperatura di saldatura (tempo di riscaldamento 1–2 minuti circa)

• Avvio della saldatura





- Orientare il **ruolo di guida (15)** verso il basso.
- Sollevare ed accostare la **soffiante dell'aria calda (8)** leggermente fino a quando la **camma d'arresto (10)** non scorre fuori dalla sede. Abbassare immediatamente la **soffiante dell'aria calda (8)**.

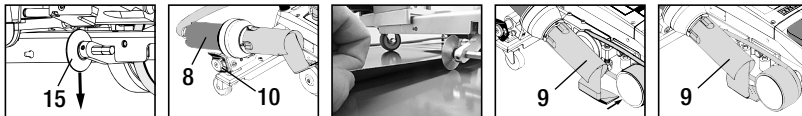

ATTENZIONE: se si fa scorrere o si abbassa eccessivamente la **soffiante dell'aria calda (8)**, l'**ugello di saldatura (9)** e il **ruolo pressore (11)** vengono a contatto. In questo modo non è possibile abbassare la **soffiante dell'aria calda (8)**.

- Sollevare leggermente il materiale superiore per teloni del rullo di guida e facendo scorrere la **soffiante dell'aria calda (8)** inserire l'**ugello di saldatura (9)** tra i teloni sovrapposti fino al fincorte.



- Il motore di azionamento si avvia in modo automatico. Avvio automatico assente (capitolo FAQ, pagina 53).
- È possibile avviare manualmente la macchina con i **comandi (4)** motore  ed e-Drive .
- Se il motore viene avviato con  ed e-Drive  e si inserisce quindi l'**ugello di saldatura (9)**, la saldatrice automatica ad aria calda continua ad avanzare per altri 30 cm circa dopo l'orientamento dell'**ugello di saldatura (9)** (disattivazione posticipata del motore).
- È possibile far avanzare la saldatrice automatica ad aria calda lungo la sovrapposizione dalla **maniglia barra di guida (33)**, **maniglia da trasporto (17)** o **maniglia di sostegno (28)**. Far avanzare la saldatrice automatica ad aria calda senza esercitare pressione sulla **maniglia barra di guida (33)**, **maniglia da trasporto (17)** o **maniglia di sostegno (28)** durante l'operazione di saldatura. La **pressione (27)** può provocare una saldatura errata. Prestare attenzione alla posizione del **ruolo di guida (15)**.

• Fine saldatura

- Al termine della saldatura, far scorrere a destra e sollevare l'**ugello di saldatura (9)** utilizzando la **soffiante dell'aria calda (8)** a partire dalla posizione di saldatura.
- Far scorrere la **soffiante dell'aria calda (8)** a destra fino a quando la **camma d'arresto (10)** non si innesta con uno scatto nella sede della **maniglia di sostegno (28)**. La **soffiante dell'aria calda (8)** è in posizione di attesa.
- Orientare il **ruolo di guida (15)** verso l'alto.

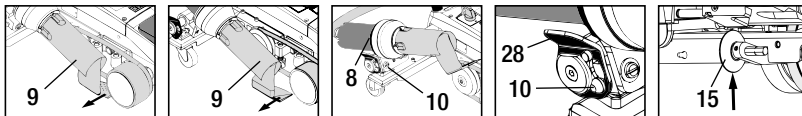

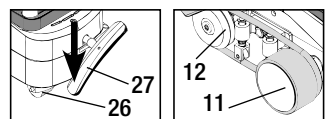

- Abbassare i **rulli di trasporto (26)** con l'orientamento della **maniglia (27)**. In questo modo si elimina il carico dal **ruolo pressore (11)** e dal **ruolo di rinvio (12)** per consentire il trasporto.



Processo di saldatura

– Al termine delle operazioni di saldatura con e-Drive  (premere 2 volte), disattivare il riscaldamento. In questo modo si raffredda l'**ugello di saldatura (9)** e la ventola si disattiva dopo 4 minuti in modo automatico (capitolo 1.8 Raffreddamento).

– Disattivare l'**interruttore principale (3)**  .

 Scollegare il cavo di collegamento dalla rete elettrica.

– Pulire l'**ugello di saldatura (9)** con la spazzola di ottone.

Apparecchio pronto al trasporto

- Orientare il **ruolo di guida (15)** verso l'alto.
- Far scorrere la **soffiante dell'aria calda (8)** a destra fino a quando la **camma d'arresto (10)** non si innesta con uno scatto nella sede della **maniglia di sostegno (28)**. La **soffiante dell'aria calda (8)** è in posizione di attesa.
- Abbassare i **rolli di trasporto (26)** con l'orientamento della **maniglia (27)**. In questo modo si elimina il carico dal **ruolo pressione (11)** e dal **ruolo di rinvio (12)** per consentire il trasporto.

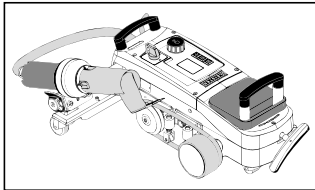
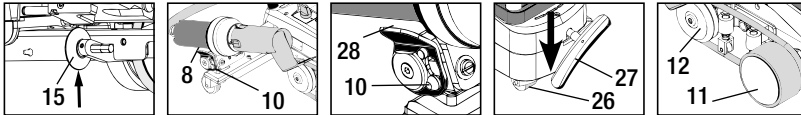

Avanzamento

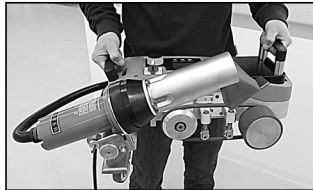

Trasporto

Combinazioni di pulsanti

Interruttore principale ON

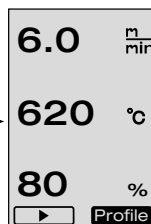

Modalità operativa

Capitolo 1

Tenere premuti i pulsanti del motore e del riscaldamento e allo stesso tempo interruttore principale ON

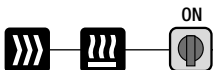

PROFILE
SETUP

Capitolo 2

1. Modalità operativa

1.1 Visualizzazione del valore nominale (dopo l'attivazione dell'apparecchio)

Interruttore principale (3) ON 

- Dopo aver attivato l'apparecchio, sul **display (5)** vengono visualizzati i valori impostati per ultimi (Fig. 3).
- In questo menu sono disattivati il sistema di riscaldamento, la ventola e il motore.
- In questa area, utilizzando i **comandi (4)** è possibile effettuare tutte le impostazioni descritte nei capitoli successivi.
- Se la temperatura della resistenza è tuttavia superiore a 80°C all'attivazione, l'indicazione passa immediatamente alla modalità COOL DOWN (capitolo 1.8 Raffreddamento) in cui la ventola funziona sempre alla massima potenza raffreddando l'**ugello di saldatura (9)**. Da questa modalità è possibile tornare alla modalità operativa premendo e-Drive  in qualsiasi momento.
- Se la temperatura della resistenza raggiunge i 60°C nella fase di raffreddamento, la ventola continua a funzionare per altri 2 minuti, quindi si disattiva in modo automatico. Il **display (5)** torna alla visualizzazione del valore nominale (Fig. 3).
- Ruotando e-Drive  su PROFILE, è possibile selezionare i diversi profili di saldatura (Fig. 4; capitolo 1.7, Selezione di PROFILE).

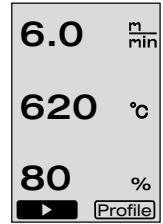





(Fig. 3)



(Fig. 4)

1.2 Visualizzazione operativa

- Premendo e-Drive  il sistema di riscaldamento e la ventola vengono avviati e la visualizzazione del valore nominale passa alla visualizzazione della modalità operativa.
- Durante il riscaldamento dell'**ugello di saldatura (9)** questa fase viene visualizzata sul **display (5)** con la barra di avanzamento, la freccia (in alto) e il valore reale della temperatura di saldatura (lampeggiante) (Fig. 5).
Se si raggiunge il valore nominale della temperatura di saldatura, la freccia ▲ e la barra di avanzamento non vengono più visualizzate (Fig. 6).
- Se la tensione di rete è al di fuori della tensione nominale preimpostata (+/- 15%), viene visualizzata l'icona con il valore della sovratensione  /sottotensione  rilevata alternata alla portata d'aria impostata. Se la portata d'aria è pari a 100 %, l'icona viene visualizzata con la sovratensione  /sottotensione  rilevata (Fig. 7).
(Possibile solo con VARIANT T1 230V-).

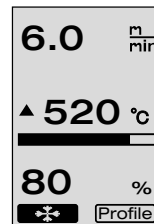

(Fig. 5)

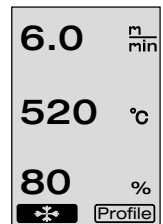

(Fig. 6)

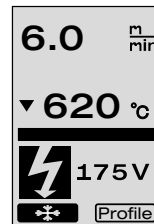

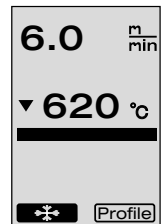

(Fig. 7)



(Fig. 8)





La sottotensione/sovratensione può influire sul risultato della saldatura.

- Se dopo un intervallo di tempo predefinito non si preme nessun pulsante, l'**ugello di saldatura (9)** NON si trova in posizione di saldatura, viene visualizzato il menu stand-by (capitolo 1.9, Stand-by).
- Se l'**ugello di saldatura (9)** si trova in posizione di attesa, è possibile selezionare i menu COOL DOWN (capitolo 1.8, Raffreddamento) o PROFILE (capitolo 1.7, Selezione di PROFILE) ruotando e-Drive .
- Se l'**ugello di saldatura (9)** è accostato, entrambe le voci del menu  Profile scompaiono dal **display (5)** e non è più possibile selezionarle.
- Mentre l'**ugello di saldatura (9)** si raffredda, questa fase viene rappresentata sul **display (5)** con la barra di avanzamento completata, la freccia ▼ (in basso) e il valore reale lampeggiante della temperatura di saldatura (Fig. 8).







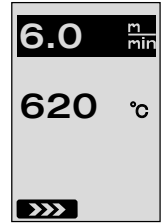

1. Modalità operativa

1.3 Impostazione della velocità del motore







- Con il pulsante  è possibile adattare la velocità del motore che si regola ruotando e-Drive  a scatti da 0,1 m/min. a partire da 1,5 m/min. fino a 18,0 m/min. È possibile effettuare questa impostazione a motore attivato o disattivato. Se si effettua nessuna digitazione utilizzando i **comandi (4)** entro 3 secondi, si conferma la nuova velocità del motore. Sul **display (5)** vengono mostrati la visualizzazione operativa del valore nominale o la modalità COOL DOWN (Fig. 9).



(Fig. 9)

- Se l'ugello di saldatura (9) non si trova nella posizione di saldatura, l'icona (START)  viene visualizzata sul **display (5)** in basso a sinistra.
- Premendo e-Drive  è possibile attivare il motore, quindi viene visualizzata l'icona (STOP) . Ruotando e-Drive  è possibile regolare direttamente la velocità del motore.
- Premendo nuovamente e-Drive  viene eseguito il comando STOP, quindi si arresta il motore. Sul display vengono mostrate la visualizzazione operativa del valore nominale o la modalità COOL DOWN.
- Se si preme il pulsante del motore  per 3 secondi, la visualizzazione passa ad un altro menu (vedere capitolo 1.6 Misurazione della lunghezza, contatore della ventola e del motore).
- Con il pulsante del sistema di riscaldamento  o il pulsante della ventola  è possibile passare ai rispettivi menu.

1.4 Impostazione della temperatura di saldatura

- Con il pulsante del riscaldamento  è possibile modificare la temperatura di saldatura. È possibile regolare la temperatura di saldatura a scatti da 10°C da 100°C a 620°C ruotando e-Drive . L'impostazione viene acquisita dopo 3 secondi se non è stato selezionato nessun pulsante nell'arco di 3 secondi (Fig. 10).
- Se si accede a questo menu dalla visualizzazione del valore nominale, è possibile avviare il sistema di riscaldamento e la ventola premendo e-Drive . Se il sistema di riscaldamento è attivato, è possibile selezionare il menu COOL DOWN (capitolo 1.8, Raffreddamento) (Fig. 11).
- Premendo il pulsante del riscaldamento  per 3 secondi, viene visualizzata la tensione di rete sotto alla velocità del motore. È possibile accedere a questa funzione solo dalla visualizzazione operativa (capitolo 1.2). (Possibile solo con VARIANT T1 230V~).
- Con il pulsante del motore  o il pulsante della ventola  è possibile passare ai rispettivi menu.

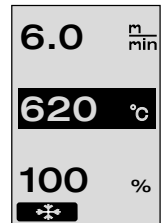



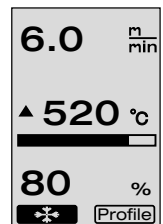



(Fig. 10)



(Fig. 11)

1. Modalità operativa

1.5 Impostazione della portata d'aria

- Con il pulsante della ventola  è possibile modificare la portata d'aria. È possibile regolare la portata d'aria a scatti del 5% a partire dal 40% al 100% ruotando e-Drive . L'impostazione viene acquisita dopo 3 secondi se non è stato selezionato nessun pulsante nell'arco di 3 secondi. Se la portata d'aria è impostata su 100%, sul **display (5)** non viene visualizzata nessuna indicazione (Fig. 12).
- Se si accede a questo menu dalla visualizzazione del valore nominale, è possibile avviare il sistema di riscaldamento e la ventola premendo e-Drive .
- Premendo e-Drive  è possibile selezionare il menu COOL DOWN (capitolo 1.8, Raffreddamento).
- Con il pulsante del motore  o il pulsante del sistema di riscaldamento  è possibile passare ai rispettivi menu.

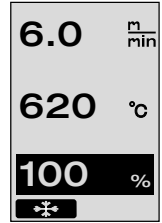

(Fig. 12)

1.6 Misurazione della lunghezza, contatore della ventola e del motore

- Questo menu (Fig. 13) viene visualizzato se si preme il pulsante del motore  per almeno 3 secondi.
- Il menu visualizza tutti i tempi di funzionamento e la distanza percorsa dall'apparecchio dall'attivazione. Non è possibile modificare la distanza totale (in questo caso: 1034 m) che mostra il percorso complessivo dall'attivazione.
- La distanza giornaliera (in questo caso: 012 m) non viene azzerata in modo automatico, ma l'utente reimpostarla su zero con **Reset** premendo e-Drive .
- Per quanto riguarda i valori TIME si tratta del tempo di funzionamento dei singoli componenti dell'apparecchio. In questo caso il tempo è assegnato alla ventola BLOW (in questo caso: 043:58) e al motore DRIVE (in questo caso: 020:10). Il tempo TOTAL si riferisce al tempo di funzionamento che conteggia le ore e i minuti (in questo caso 143:12) durante i quali l'**interuttore principale (3)** era attivato.
- Se si seleziona freccia BACK  premendo e-Drive , si torna al menu da cui è stato premuto il pulsante del motore .

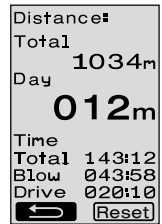

(Fig. 13)

1. Modalità operativa

1.7 Selezione di PROFILE

- Se l'indicazione **Profile** è attivata sul **display (5)** in basso a destra, è possibile caricare i profili premendo e-Drive . Quindi viene visualizzato il messaggio SELECT PROFILE. Ruotando e-Drive  è possibile selezionare un profilo. L'utente può personalizzare i profili FREE 1–7 (vedere capitolo 2 PROFILE SETUP). Tutti gli altri profili sono dotati di valori assegnati in modo fisso e possono essere definiti dall'utente (Fig. 14).
- Ruotando e-Drive  è possibile attivare le frecce sul **display (5)** in basso a sinistra o a destra.
Freccia a destra  premendo e-Drive  alla pagina successiva (Fig. 15).
Freccia a sinistra  premendo e-Drive  alla pagina precedente (Fig. 16).
- Se si attiva freccia BACK  ruotando e-Drive , si ritorna al menu da cui è stato selezionato il menu PROFILE premendo e-Drive  (Fig. 15).

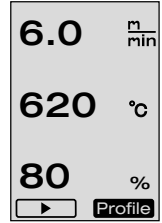

(Fig. 14)

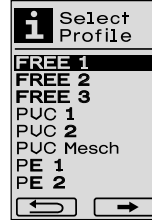

(Fig. 15)

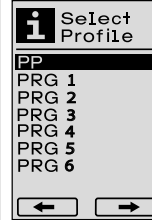



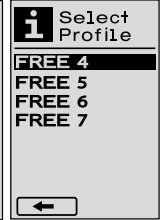



(Fig. 16)



Effettuare una saldatura di prova in base alle istruzioni di saldatura del produttore del materiale e alle normative o alle direttive nazionali. Verificare la saldatura di prova.

1.8 Raffreddamento

- Se si seleziona l'icona  premendo e-Drive  (Fig. 17), viene visualizzato il messaggio COOL DOWN OK? (Fig. 18). Premendo e-Drive  viene attivata l'icona OK sul **display (5)** in basso a destra. In questo modo si avvia il processo di raffreddamento.
- Durante il processo di raffreddamento la portata d'aria aumenta fino a raggiungere il 100% e viene visualizzata la temperatura di saldatura corrente (Fig. 19). Se la temperatura di saldatura scende sotto ai 60°C, la ventola continua a funzionare per altri 2 minuti, quindi si disattiva in modo automatico. A questo punto si passa alla visualizzazione del valore nominale.
- Premendo e-Drive  durante il processo di raffreddamento, il sistema di riscaldamento viene avviato e sul **display (5)** viene mostrata la visualizzazione operativa (vedere capitolo 1.2 Visualizzazione operativa).
- Se il menu COOL DOWN è attivo, è possibile attivare/disattivare manualmente il motore con il pulsante . I pulsanti del sistema di riscaldamento  e della ventola  non rivestono nessuna funzione.

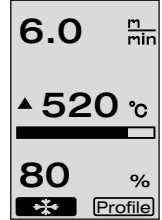

(Fig. 17)



(Fig. 18)

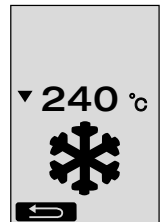

(Fig. 19)

1. Modalità operativa

1.9 Stand-by

- Se l'**ugello di saldatura (9)** non è in posizione di saldatura e non viene selezionato nessun pulsante durante lo stand-by, la cui durata è predefinita dall'utente, si avvia in modo automatico la modalità COOL DOWN al termine del conto alla rovescia (Fig. 20). Si avvia il processo di raffreddamento.
- Se prima della fine del conto alla rovescia (180 secondi) si preme e-Drive , il **display (5)** passa alla visualizzazione operativa (vedere capitolo 1.2 Visualizzazione operativa).
- Impostazione della durata dello stand-by (capitolo 2.3, STAND-BY SETUP).

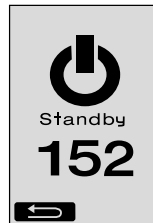

(Fig. 20)

1.10 Messaggi d'errore

- Se si verifica un malfunzionamento della saldatrice automatica ad aria calda VARIANT T1, sul **display (5)** viene visualizzato un messaggio che presenta anche un codice d'errore. Questo codice fa riferimento ad una descrizione più dettagliata dell'errore e riportata nel seguente elenco in modo chiaro.
- Per gli errori 02 e 40 vengono visualizzate icone separate.
- Per tutti gli altri errori viene visualizzata l'icona della chiave che significa una richiesta al servizio di assistenza tecnica.



Error	Tipo d'errore
Err00	Sistema elettronico di controllo difettoso
Err01	Interruzione o cortocircuito della sonda termica
Err02	Resistenza / sistema elettronico difettoso (interruzione in un avvolgimento / entrambi gli avvolgimenti)
Err04	Triac difettoso (uno o entrambi i triac sono difettosi)
Err08	Motore della ventola difettoso
Err40	Sottotensione 25% (tensione di rete 75%) solo VARIANT T1 230 V~

2. PROFILE SETUP



























2.1 Combinazione di pulsanti PROFILE SETUP

Tenere premuti i pulsanti del motore e del sistema di riscaldamento e allo stesso tempo interruttore principale ON



2. PROFILE SETUP

2.2 Creazione dei profili

- In PROFILE SETUP è possibile creare 7 profili personalizzati in cui è possibile configurare liberamente il nome e tutti e tre i parametri motore , sistema di riscaldamento  e ventola , e quindi memorizzarli premendo e-Drive  (Fig. 21).
- È possibile selezionare le diverse voci dei menu con i **comandi (4)**. Premendo e-Drive  si torna alla selezione PROFILE SETUP.
- Ruotando e-Drive  è possibile attivare le frecce sul **display (5)** in basso a sinistra o a destra.
Freccia a destra  premendo e-Drive  alla pagina successiva (Fig. 15).
Freccia a sinistra  premendo e-Drive  alla pagina precedente (Fig. 16).
- Se si attiva l'icona  ABC ruotando e-Drive , si raggiunge il menu PROFILE NAME premendo e-Drive  (Fig. 22).
- Nel menu PROFILE NAME è possibile selezionare i caratteri **_ / . /** dalla A alla Z / da 0 a 9, le frecce a sinistra o a destra e le icone SAVE  o BACK  ruotando e-Drive .
- Modifica del nome del profilo
 - Ruotando e-Drive  è possibile selezionare le frecce a sinistra o a destra. Se la freccia a destra viene attivata premendo e-Drive , il cursore all'interno del nome del profilo (nero) salta un carattere verso destra.
Se la freccia a sinistra viene attivata premendo e-Drive , il cursore all'interno del nome del profilo (nero) salta un carattere verso sinistra (Fig. 23).
 - Ruotando e-Drive  è possibile selezionare il carattere desiderato (**_ / . /** dalla A alla Z / da 0 a 9). A questo punto premendo e-Drive  il carattere evidenziato in nero all'interno del nome del profilo viene sostituito con il carattere precedentemente selezionato.
- Memorizzazione o eliminazione del nome del profilo
 - Se si seleziona l'icona SAVE  ruotando e-Drive , si memorizza il nome del profilo premendo e-Drive .
 - Se si seleziona l'icona BACK  ruotando e-Drive , si elimina il nome del profilo (non memorizzato) premendo e-Drive .

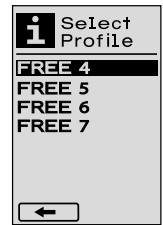

(Fig. 21)

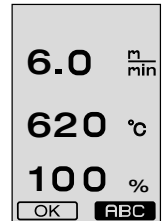

(Fig. 22)





(Fig. 23)



Effettuare una saldatura di prova in base alle istruzioni di saldatura del produttore del materiale e alle normative o alle direttive nazionali.

2.3 STAND-BY SETUP

- La durata dello stand-by definisce l'intervallo di tempo che deve trascorrere (senza digitazioni dei pulsanti, ugello di saldatura non in posizione di saldatura) prima dell'attivazione automatica del processo di raffreddamento (vedere capitolo 1.8 Raffreddamento).
 - Ruotando e-Drive  è possibile impostare la durata da 5 a 120 minuti. L'impostazione di fabbrica è pari a 40 minuti.
- Premendo e-Drive  si torna alla selezione PROFILE SETUP.



- La macchina si disattiva automaticamente
 - Con il funzionamento in modalità stand-by la macchina viene disattivata in modo automatico una volta trascorso il tempo impostato (impostazione di fabbrica 40 minuti).
 - In caso di necessità, aumentare la durata dello stand-by (pagina 51, 2. PROFILE SETUP, 2.3 STAND-BY SETUP).
- La qualità della saldatura è scarsa
 - Controllare la velocità del motore, la temperatura di saldatura e la portata d'aria
 - Pulire l'**ugello di saldatura (9)** con la spazzola di ottone
 - L'**ugello di saldatura (9)** è impostato in modo errato

Effettuare l'impostazione base dell'ugello di saldatura (9) come riportato di seguito.

- Far raffreddare l'**ugello di saldatura (9)** (pagina 49, 1. Modalità operativa, 1.8 Raffreddamento).
- Allentare le viti ad esagono cavo presente sul supporto dell'apparecchio.
- Effettuare l'impostazione dell'angolazione con dei movimenti di orientamento della **soffiante dell'aria calda (8)**.
- L'**ugello di saldatura (9)** deve essere accostato (**freccia L**) al **calibro degli ugelli (34)** e (**freccia R**) alla base.
- Serrare le viti ad esagono cavo presente sul supporto dell'apparecchio.
- Posizionare il **calibro degli ugelli (34)**. Prestare attenzione alla scala sul **calibro degli ugelli (34)**.
- Portare la **soffiante dell'aria calda (8)** in posizione di saldatura.
- Allentare le **viti di regolazione asse orientabile (25)**.
- Orientare la **soffiante dell'aria calda (8)** sul **calibro degli ugelli (34)** in posizione parallela.
- Serrare le **viti di regolazione asse orientabile (25)**.
- Rimuovere il **calibro degli ugelli (34)** ed effettuare una saldatura di prova.

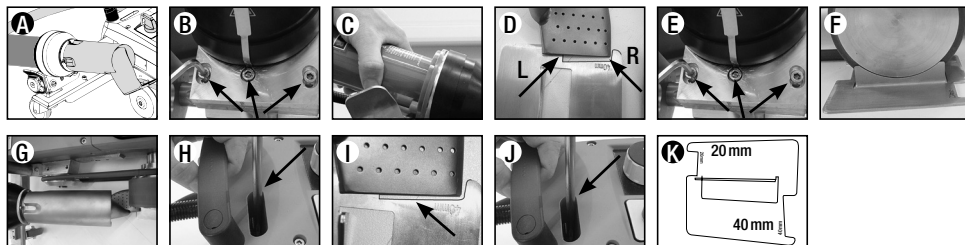

- Temperatura impostata non raggiunta (l'indicazione della temperatura lampeggia)
 - Controllare la tensione di rete
 - Ridurre la portata d'aria
 - Ridurre la temperatura
- La soffiante dell'aria calda non si arresta in posizione di saldatura
 - È necessario impostare il tassello di spinta a sfera come riportato di seguito.
 - Far raffreddare l'**ugello di saldatura (9)** (pagina 49, 1. Modalità operativa, 1.8 Raffreddamento)
 - Portare l'**ugello di saldatura (9)** in posizione di saldatura
 - Serrare leggermente la **vite (30)** con un cacciavite, quindi far effettuare alla **vite (30)** 1/2 giro all'indietro.

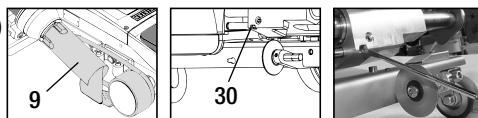

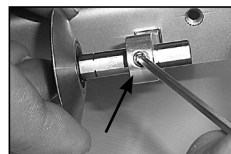
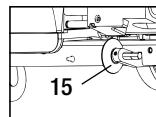
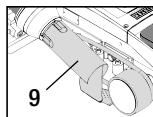

- La larghezza della saldatura non è costante
 - Effettuare l'impostazione di precisione del rullo di guida come riportato di seguito.
 - Far raffreddare l'**ugello di saldatura (9)** (pagina 49, 1. Modalità operativa, 1.8 Raffreddamento).
 - Portare l'**ugello di saldatura (9)** in posizione di saldatura.
 - Allentare la vite ad esagono cavo del **rullo di guida (15)**.
 - Far scorrere il **rullo di guida (15)** nella posizione desiderata.
 - Serrare la vite ad esagono cavo.
 - Effettuare la saldatura di prova.

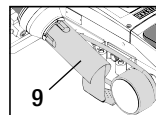
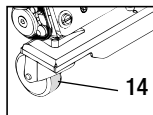

- La saldatrice automatica ad aria calda si allontana dalla saldatura (saldatura a sovrapposizione)
 - Effettuare l'impostazione di precisione della traccia del **rullo orientabile (14)** come riportato di seguito.



- Far raffreddare l'**ugello di saldatura (9)** (pagina 49, 1. Modalità operativa, 1.8 Raffreddamento)

- Disattivare l'**interruttore principale (3)** OFF .
- Scollegare il cavo di collegamento dalla rete elettrica. .

- Rimuovere il **peso supplementare (16)**.
- Inclinare lateralmente la saldatrice automatica.

- Allentare la **vite d'arresto per l'impostazione di precisione della traccia (31)** e far scorrere la **leva per l'impostazione di precisione della traccia (32)** nella posizione desiderata.



- Serrare la **vite d'arresto per l'impostazione di precisione della traccia (31)**.

- Portare la saldatrice automatica ad aria calda in posizione di saldatura

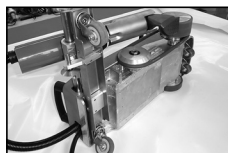

- Inserire il **peso supplementare (16)**.
- Mettere nuovamente in funzione la saldatrice automatica ad aria calda.
- Effettuare la saldatura di prova.



- Il sistema di avvio automatico non funziona



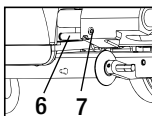
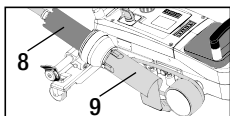
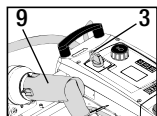

Se il motore di azionamento non si avvia in modo automatico dopo l'inserimento dell'**ugello di saldatura (9)**, il **sensore di avviamento (6)** è eventualmente impostato in modo errato.

- Impostare il **sensore di avviamento (6)** come riportato di seguito.
- Far raffreddare l'**ugello di saldatura (9)** (pagina 49, 1. Modalità operativa, 1.8 Raffreddamento).
- Disattivare l'**interruttore principale (3)** OFF .
- Orientare ed innestare con uno scatto l'**ugello di saldatura (9)** in posizione di saldatura utilizzando la **soffiante dell'aria calda (8)**.
- Effettuare l'impostazione del **sensore di avviamento (6)** dalla **vite filettata (7)** con la chiave a brugola; **IMPORTANTE: distanza di attivazione 0,2 – 0,5mm**
- Controllare il funzionamento



Se il motore di azionamento non parte ancora in modo automatico, è necessario contattare il centro di assistenza.

Applicazioni della saldatura

	Saldatura a sovrapposizione	Orlatura	Orlo a giorno (fino a 70 mm)	Cordoncino di rinforzo	Rinforzo preimpostato
 <p>Versione standard</p>	●	●	●		
 <p>Componente ausiliario di orlatura / rinforzo</p>		●	●	●	
 <p>Premibarra</p>		●		●	●
 <p>Guida del rinforzo</p>				●	●

Modalità d'impiego

Al posto del rullo di guida (15) è possibile lavorare anche con il componente ausiliario di orlatura / rinforzo.

Possibile anche con la versione standard e il fissaggio del telone.

Possibile anche con la versione standard e il fissaggio del telone.

Si consiglia una base con cava longitudinale di trascinamento per il rinforzo.

Fissaggio senza pieghe del rinforzo preimpostato.

Modello

Solido fissaggio dei teloni.

Indicazione della sovrapposizione dell'orlatura per un miglior controllo della guida.

Indicazione della sovrapposizione dell'orlatura per un miglior controllo della guida.

Indicazione della sovrapposizione dell'orlatura per un miglior controllo della guida. Lasciar funzionare l'apparecchio liberamente, guida manuale del telone con cordoncino.

Versioni di VARIANT T1 Leister

- Cod. articolo 141.891 VARIANT T1, 230 V / ugello di saldatura da 40 mm / con spina Euro
- Cod. articolo 141.892 VARIANT T1, 230 V / ugello di saldatura da 20 mm / con spina Euro
- Cod. articolo 141.893 VARIANT T1, 400 V / ugello di saldatura da 40 mm / con spina CEE (3LNPE)
- Cod. articolo 141.894 VARIANT T1, 400 V / ugello di saldatura da 20 mm / con spina CEE (3LNPE)
- Cod. articolo 147.739 VARIANT T1, 200 V / ugello di saldatura da 40 mm / senza spina
- Cod. articolo 147.748 VARIANT T1, 200 V / ugello di saldatura da 20 mm / senza spina

Accessori

Per motivi tecnici e rilevanti dal punto di vista della sicurezza è consentito utilizzare esclusivamente accessori Leister.

- | | |
|--|---|
| Cod. articolo 142.650 kit di orlatura / rinforzo completo | Cod. articolo 139.438 peso supplementare |
| Cod. articolo 140.530 componente ausiliario di orlatura / rinforzo | Cod. articolo 137.843 maniglia a T barra di guida parte superiore |
| Cod. articolo 142.221 premibarra | Cod. articolo 116.798 spazzola di ottone |
| Cod. articolo 141.326 guida del rinforzo | Cod. articolo 142.705 valigetta dell'apparecchio |

Formazione

- Leister Technologies AG e i rispettivi centri d'assistenza autorizzati offrono corsi di saldatura e di formazione gratuiti. Informazioni all'indirizzo www.leister.com.

Manutenzione

- In presenza di formazioni di sporco è necessario pulire l'ingresso dell'aria nella **soffiante dell'aria calda (5)** con un pennello
- Pulire l'**ugello di saldatura (9)** con la spazzola di ottone
- Controllare la presenza di guasti elettrici e meccanici nel **cavo di collegamento alla rete (1)** e nella spina elettrica.

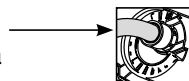

Servizio di assistenza e riparazione

- Se il contatore del motore raggiunge le 400 h o il contatore della ventola le 2000 h, sul **display (5)** viene visualizzato il messaggio **MAINTENANCE SERVICING** alla successiva attivazione dell'**interruttore principale (3)**. Questo messaggio viene visualizzato per 10 secondi e non può essere bypassato con gli **elementi di comando (4)**.
- Le riparazioni devono essere eseguite esclusivamente da un **Centro di assistenza Leister** autorizzato. I centri di assistenza garantiscono un **servizio di riparazione** professionale ed affidabile **entro 24 ore** con pezzi di ricambio originali conformi agli schemi elettrici e agli specifici elenchi.

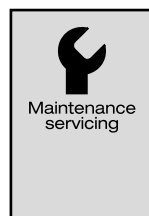

Garanzia

- A questo prodotto si applicano i diritti previsti per la garanzia concessi dal partner di distribuzione/rivenditore diretto, a partire dalla data di acquisto. In caso di ricorso alla garanzia (fanno fede la fattura o la bolla di consegna), sono previste la fornitura sostitutiva o la riparazione di difetti di fabbricazione o di lavorazione a cura del partner di distribuzione. La garanzia non si applica agli elementi riscaldanti.
- È esclusa qualsiasi ulteriore garanzia non espressamente prevista dalle vigenti norme di diritto cogente.
- Sono esclusi dalla garanzia i danni riconducibili alla naturale usura, al sovraccarico o alla scorretta manipolazione.
- Il ricorso alla garanzia decade per gli apparecchi sottoposti a modifiche o alterazioni da parte dell'acquirente.

Nous vous remercions pour votre achat de la soudeuse automatique à air chaud VARIANT T1

Vous avez choisi une soudeuse automatique à air chaud de premier choix, fabriquée avec des matériaux de haute qualité. Cet appareil a été développé et produit selon les technologies de soudage les plus récentes. Chaque soudeuse VARIANT T1 est soumise à un contrôle strict de qualité avant de quitter l'usine en Suisse.

Table des matières

Application, avertissement, attention	page	57
Conformité, élimination, caractéristiques techniques	page	58
Description de l'appareil, éléments de commande	page	59
Icônes d'informations, icônes actives, informations rapides	page	60
Etat de service, positionnement de l'appareil	page	61
Cycle de soudage	page	62/63
Préparation au transport, combinaisons de touches	page	63
Mode de travail (chapitre 1)		
1.1 Affichage de la valeur de consigne		
1.2 Affichage de travail	page	64
1.3 Réglage de la vitesse d'entraînement		
1.4 Réglage de la température de soudage	page	65
1.5 Réglage de la quantité d'air		
1.6 Mesure des longueurs, compteurs de soufflerie et d'entraînement	page	66
1.7 Sélection des profils		
1.8 Refroidissement	page	67
1.9 Mode Veille		
1.10 Messages d'erreur		
Configuration du profil (chapitre 2)		
2.1 Configuration du profil, combinaison de touches	page	68
2.2 Création de profils		
2.3 Configuration du mode Veille	page	69
FAQ	page	70/71
Applications de soudage	page	72
Modèles, accessoires, formation, entretien, maintenance et réparation, garantie	page	73



Lisez attentivement les instructions d'utilisation avant de mettre l'appareil en service et conservez-la à disposition pour une consultation ultérieure.

Leister VARIANT T1 Soudeuse automatique à air chaud

Application

L'appareil ne doit être utilisé que dans des locaux bien ventilés. Si nécessaire, il faudra recourir à un dispositif d'aspiration ou à du matériel de protection personnel. Veiller à ne pas brûler le matériau lors du processus de soudage. Contrôler avec le fabricant de matériaux l'existence d'additifs néfastes pour la santé. Les prescriptions légales en termes de protection de la santé en vigueur dans le pays doivent s'appliquer.

- Soudeuse automatique à air chaud à main pour des soudures par recouvrement, d'ourlets et de ralingues de matériaux de bâches (PVC et matériaux similaires).
- **Utilisation uniquement dans des espaces bien ventilés**



Avertissement



Danger de mort à l'ouverture de l'appareil, car des composants et des liaisons sous tension sont découverts. Avant d'ouvrir l'appareil, retirez la fiche secteur de la prise de courant.



Risque d'incendie et d'explosion en cas d'utilisation non conforme de décapeurs thermiques, en particulier à proximité de matériaux inflammables et de gaz explosifs.



Risque de brûlure ! Ne touchez pas la buse de soudage si elle est chaude. Laissez refroidir l'appareil. Ne dirigez pas le jet d'air chaud sur les personnes ou les animaux.



Raccordez l'appareil à une **prise de courant équipée d'un conducteur de protection**. Toute rupture du conducteur de protection à l'intérieur ou à l'extérieur de l'appareil est dangereuse ! **Utilisez exclusivement un câble de prolongation équipé d'un conducteur de protection !**



Attention



La **tension nominale** indiquée sur l'appareil doit correspondre à la tension du secteur. EN 61000-3-11; $Z_{max} = 0.0.164 \Omega + j 0.0.102 \Omega$. Ci nécessaire, consulter votre distributeur d'électricité. En cas de **panne de courant**, sortez la soufflerie à air chaud.



Un **interrupteur FI** est absolument nécessaire pendant l'utilisation de l'appareil sur des chantiers pour assurer la protection des personnes.



L'appareil doit fonctionner **sous supervision**. La chaleur peut atteindre des matériaux inflammables se trouvant hors de portée de vue. L'appareil doit être utilisé exclusivement par des **spécialistes formés** ou sous leur supervision. L'utilisation de l'appareil par des enfants est strictement interdite.



Protégez l'appareil de l'humidité et de la pluie.



L'appareil ne doit pas être soulevé par le poids supplémentaire.

Conformité

Leister Technologies AG, Galileo-Strasse 10, CH-6056 Kaegiswil/Suisse atteste que le produit, dans la version que nous avons mise en circulation, satisfait aux exigences des directives CE suivantes.

Directives : 2006/42/EC, 2014/30/EU, 2011/65/EU
Normes harmonisées : EN ISO 12100, EN 55014-1, EN 55014-2, EN 61000-3-2, EN 61000-3-3, EN 61000-3-11 (Z_{max}), EN 61000-6-2, EN 62233, EN 60335-1, EN 60335-2-45, EN IEC 63000

Kaegiswil, 05.11.2020

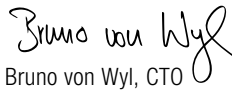
Bruno von Wyl, CTO

Christoph Baumgartner, GM

Elimination



Les appareils électroniques, les accessoires et les emballages doivent être recyclés en respectant l'environnement. Ne pas jeter les appareils électroniques avec les déchets ménagers !

Caractéristiques techniques

Tension	V~	200	230	400 (2LNPE)	V~	200	230	400 (2LNPE)
Puissance	W	4200	3680	5700	W	4200	3680	5700
Fréquence	Hz	50 / 60			Hz	50 / 60		
Température	°C	100 – 620 réglage continu			°F	212 – 1148 réglage continu		
Entraînement	m/min.	1.5 – 18 réglage continu			ft/min	4.9 – 59.1 réglage continu		
Quantité d'air	%	40 – 100			%	40 – 100		
Niveau d'émission	L_{pA} (dB)	70			L_{pA} (dB)	70		
Poids	kg	22			lbs	48.5		
sans câble d'alimentation secteur								
Dimensions L × l × H	mm	500 × 400 × 195			inch	19.7 × 15.8 × 7.7		
Marque de conformité								
Classe de protection I								

Tension d'alimentation non réversible

Sous réserve de modifications techniques

Description de l'appareil

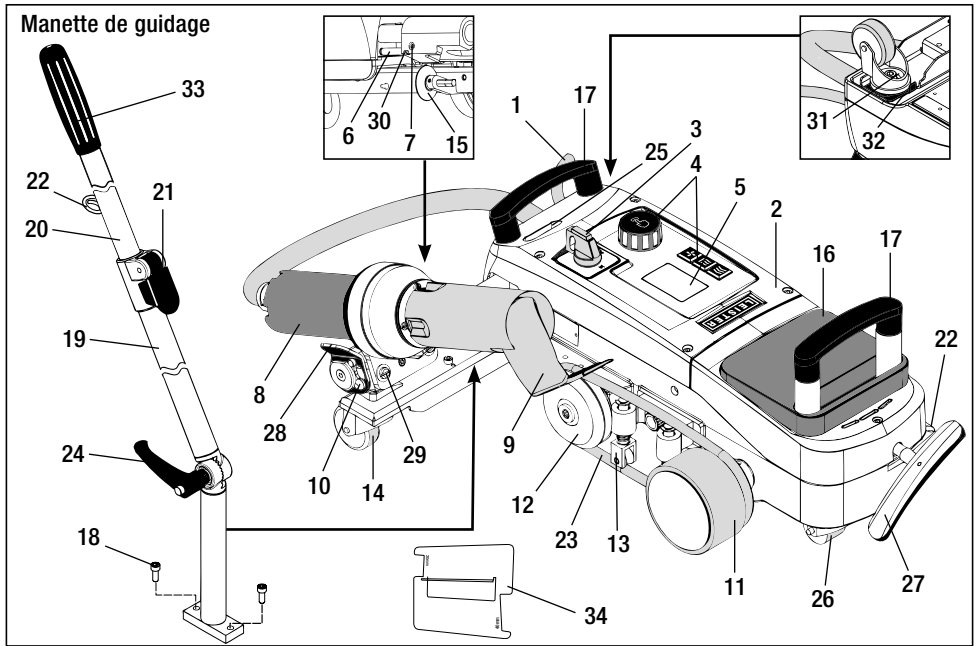

- | | | |
|---|--|--|
| 1 Câble d'alimentation secteur | 12 Poulie de renvoi | 22 Support pour câble d'alimentation secteur |
| 2 Boîtier | 13 Serre-flan | 23 Courroie ronde |
| 3 Commutateur principal | 14 Poulie de guidage | 24 Vis de levier
Partie inférieure de la manette de guidage |
| 4 Éléments de commande | 15 Rouleau de guidage | 25 Vis d'ajustage du pivot |
| 5 Écran | 16 Poids supplémentaire | 26 Roulette de transport |
| 6 Capteur de démarrage | 17 Poignée de transport | 27 Poignée pour dispositif de soulèvement |
| 7 Vis sans tête pour le réglage du capteur de démarrage | 18 Vis à tête cylindrique | 28 Poignée |
| 8 Soufflerie à air chaud | 19 Partie inférieure de la manette de guidage | 29 Ajustage angulaire du support de l'appareil |
| 9 Buse de soudage | 20 Partie supérieure de la manette de guidage | 30 Vis d'arrêt pour position de soudage |
| 10 Came d'arrêt pour soufflerie à air chaud | 21 Levier de blocage
Partie supérieure de la manette de guidage | 31 Vis d'arrêt pour le réglage précis du tracé |
| 11 Rouleau de pression | | 32 Levier pour le réglage précis du tracé |
| | | 33 Poignée de la manette de guidage |
| | | 34 Calibre pour buses |

Commutateur principal (3)



Pour la mise sous tension/hors tension de la soudeuse automatique à air chaud VARIANT T1

Éléments de commande (4)



e-Drive

Le bouton e-Drive sert de navigateur.

Il remplit deux fonctions :



Tournez vers la gauche ou la droite pour régler divers menus ou valeurs



Appuyez dessus pour confirmer ou activer



Entraînement

Réglage de la vitesse d'entraînement



Chauffage

Réglage de la température de soudage



Soufflerie

Réglage de la quantité d'air

Icônes d'informations

Les icônes suivantes sont affichées sur l'écran pour fournir des informations.



Refroidissement de la buse de soudage



Appareil en mode Veille, il s'arrête à la fin de ce délai



Contacter le SAV compétent



Indique que la température augmente



Indique que la température baisse



Barre de progression

Icônes actives

Les icônes suivantes sont affichées sur l'écran et déclenchées si vous appuyez sur le bouton e-Drive .



Mise sous tension du chauffage et de la soufflerie (si la soufflerie ne fonctionne pas encore)



Arrêt de l'entraînement



Démarrage de l'entraînement



Refroidissement automatique (chauffage éteint, soufflerie allumée)



Remonter dans la hiérarchie (retour au programme précédent)



Entrée, confirmation

Profile

Sélection des profils

Save

Enregistrer le nom modifié

ABC

Modifier le nom du profil



Page suivante



Page précédente

Reset

Réinitialisation de la distance journalière

Icônes d'informations





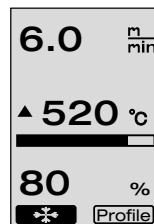
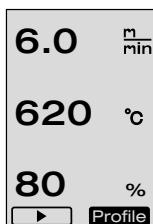
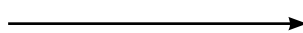







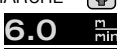

Icônes actives

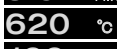

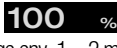

Informations rapides

Comment démarrer la soudeuse automatique à air chaud VARIANT T1 ?

- Raccordez le câble d'alimentation secteur au secteur  
- Positionnez le **commutateur principal (3)** sur MARCHE 
- Appuyez sur la touche Entraînement  →  tournez le bouton e-Drive 
- Appuyez sur la touche Chauffage  →  tournez le bouton e-Drive 
- Appuyez sur la touche Soufflerie  →  tournez le bouton e-Drive 
- Appuyez sur le bouton e-Drive  temps de chauffage env. 1 – 2 minutes → 
- Procédez à un essai de soudage conformément aux instructions de soudage du fabricant de matériaux et aux normes ou directives nationales. Contrôlez l'essai de soudage.
- Soudage 

Comment mettre la soudeuse automatique à air chaud VARIANT T1 hors circuit ?

- Appuyez sur le bouton e-Drive  (ill. 1).
- Appuyez sur le bouton e-Drive  « Cool down OK » (Refroidissement OK) et laissez refroidir environ 4 minutes (ill. 2). La soufflerie se met automatiquement hors circuit.
- Une fois la **buse de soudage (9)** refroidie, positionnez le **commutateur principal (3)** sur ARRÊT OFF 

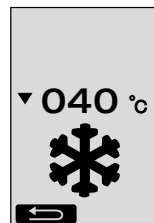
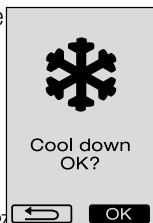

(ill. 1)

(ill. 2)

Etat de service

- Avant la mise en service, contrôlez le **câble d'alimentation secteur (1)** et la fiche ainsi que le câble de prolongation à la recherche de dommages électriques et mécaniques.
- Le réglage de base de la **buse de soudage (9)** est effectué en usine.
- Contrôlez le réglage de base de la **buse de soudage (9)**
 - Le contrôle peut être réalisé à l'aide du **calibre pour buses (34)** ou conformément aux détails A et B.

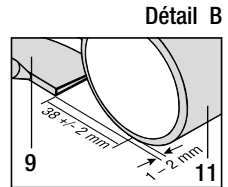
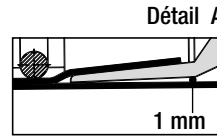
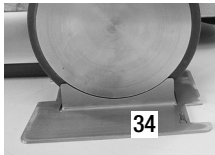

- Montez la **manette de guidage** à l'aide des **vis à tête cylindrique (18)**.
 - Placez la **partie inférieure de la manette de guidage (19)** dans la position souhaitée à l'aide de la **vis de levier (24)** et la **partie supérieure de la manette de guidage (20)** à l'aide du **levier de blocage (21)**.
 - Suspendez la décharge de traction du **câble d'alimentation secteur (1)** dans le **support (22)**.

- Positionnez le **poids supplémentaire (16)** (deux poids supplémentaires max.)

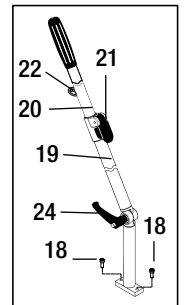
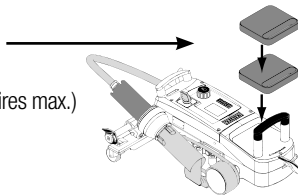

Raccordez l'appareil à la tension nominale. La tension nominale indiquée sur l'appareil doit correspondre à la tension du secteur.
En cas de **panne de courant**, sortez la **soufflerie à air chaud (8)** en position d'arrêt.

Positionnement de l'appareil

- Le matériau de bâche doit être propre au niveau du recouvrement ainsi que sur la partie supérieure et inférieure.
- La **buse de soudage (9)**, le **rouleau de pression (11)**, la **poulie de renvoi (12)** et la **courroie ronde (23)** ainsi que le **serre-flan (13)** doivent être propres.
- Si la soudeuse automatique à air chaud n'est pas prête pour le transport, soulevez l'appareil à l'aide de la **poignée (27)** du dispositif de soulèvement. Les **roulettes de transport (26)** sont désormais opérationnelles.
- Déplacez la soudeuse automatique à air chaud en position de soudage.
- A l'aide de la **poignée (27)**, abaissez la soudeuse automatique à air chaud en position de soudage. Les **roulettes de transport (26)** ne jouent plus aucun rôle et sont ainsi dégagées.
- Orientez le **rouleau de guidage (15)** vers le bas.
- Le **rouleau de guidage (15)** doit être parallèle au **rouleau de pression (11)** (détail C).

Préparation au transport
Poignée à gauche

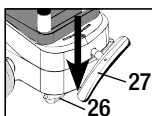

Position de soudage
Poignée à droite

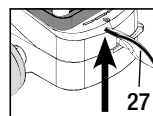

Détail C

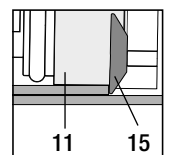

Cycle de soudage

• Préparation



Procédez à un **essai de soudage conformément aux instructions de soudage du fabricant de matériaux et aux normes ou directives nationales. Contrôlez l'essai de soudage.**

- Réglez les paramètres de soudage Entraînement, Chauffage et Soufflerie (chapitre 1 Mode de travail)
- La température de soudage doit être atteinte (temps de chauffage : env. 1 – 2 min)

• Démarrage du soudage





- Orientez le **rouleau de guidage (15)** vers le bas.
- Faites pivoter légèrement la **soufflerie à air chaud (8)** jusqu'à ce que la **came d'arrêt (10)** soit extraite de l'évidement. Abaissez immédiatement la **soufflerie à air chaud (8)**.



ATTENTION : Si la **soufflerie à air chaud (8)** est poussée et abaissée excessivement, la **buse de soudage (9)** et le **rouleau de pression (11)** entrent en contact. La **soufflerie à air chaud (8)** ne peut alors pas être abaissée.

- Soulevez légèrement le matériau de bache supérieur dans la zone du rouleau de guidage et insérez la **buse de soudage (9)** jusqu'à la butée entre les bâches se chevauchant en poussant la **soufflerie à air chaud (8)**.



- Le moteur d'entraînement démarre automatiquement. Aucun démarrage automatique (chapitre FAQ, page 71)
- La machine peut être démarrée manuellement avec les **éléments de commande (4)** Entraînement  et le bouton e-Drive 
- Si l'entraînement est démarré au moyen de la touche  et du bouton e-Drive  et la **buse de soudage (9)** est ensuite poussée, la soudeuse automatique à air chaud se déplace encore d'environ 30 cm après le pivotement de la **buse de soudage (9)** (retard à la mise hors tension de l'entraînement).
- La soudeuse automatique à air chaud peut être dirigée au niveau de la **poignée de la manette de guidage (33)**, de la **poignée de transport (17)** ou de la **poignée (28)** le long du recouvrement. Guidez la soudeuse automatique à air chaud sans pression sur la **poignée de la manette de guidage (33)**, la **poignée de transport (17)** ou la **poignée (28)** pour le soudage. Une pression sur les poignées peut entraîner des erreurs de soudage. Veillez au bon positionnement du **rouleau de guidage (15)**.

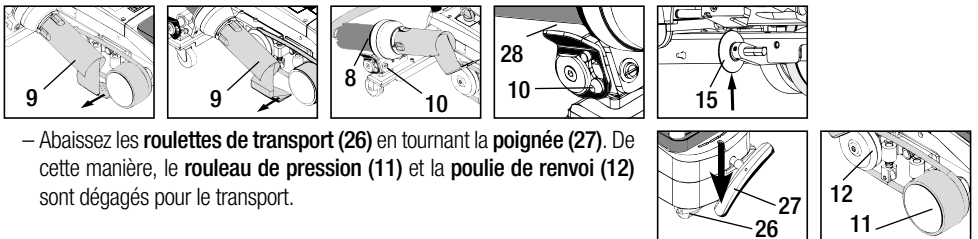

• Fin du soudage

- Après le soudage, poussez vers la droite la **buse de soudage (9)** hors de sa position de soudage à l'aide de la **soufflerie à air chaud (8)** et relevez-la.
- Poussez la **soufflerie à air chaud (8)** vers la droite jusqu'à ce que la **came d'arrêt (10)** s'enclenche dans l'évidement de la **poignée (28)**. La **soufflerie à air chaud (8)** se trouve en position d'arrêt.
- Orientez le **rouleau de guidage (15)** vers le haut.



- Abaissez les **roulettes de transport (26)** en tournant la **poignée (27)**. De cette manière, le **rouleau de pression (11)** et la **poulie de renvoi (12)** sont dégagés pour le transport.

Cycle de soudage

– A la fin des travaux de soudage, mettez le chauffage hors circuit au moyen du bouton e-Drive   (appuyez 2 fois). La **buse de soudage (9)** est ainsi refroidie et la soufflerie s'arrête automatiquement au bout de 4 minutes environ (chapitre 1.8 Refroidissement).

– Mettez le **commutateur principal (3)**  hors circuit

 Débranchez le câble d'alimentation secteur du secteur électrique.

– Nettoyez le **buse de soudage (9)** avec la brosse en laiton

Préparation au transport

- Orientez le **rouleau de guidage (15)** vers le haut.
- Poussez la **soufflerie à air chaud (8)** vers la droite jusqu'à ce que la **came d'arrêt (10)** s'enclenche dans l'évidement de la **poignée (28)**. La **soufflerie à air chaud (8)** se trouve en position d'arrêt.
- Abaissez les **roulettes de transport (26)** en tournant la **poignée (27)**. De cette manière, le **rouleau de pression (11)** et la **poulie de renvoi (12)** sont dégagés pour le transport.

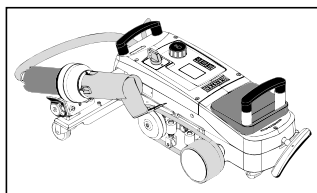
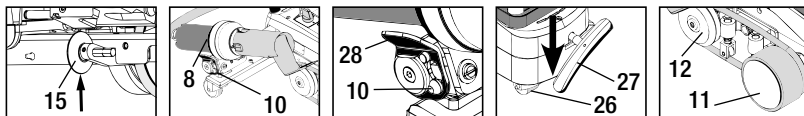

Déplacement



Transport

Combinaisons de touches

Commutateur principal
MARCHE



Maintenez les touches
Entraînement et
Chauffage enfoncées
tout en positionnant le
commutateur principal
sur MARCHE

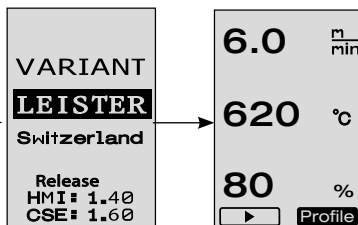
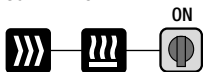

Mode de travail
Chapitre 1

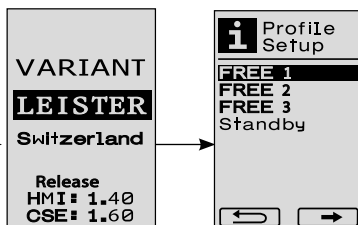



Configuration
du profil
Chapitre 2

1. Mode de travail

1.1 Affichage de la valeur de consigne (après la mise en marche de l'appareil)

Positionnez le **commutateur principal (3)** sur MARCHE 

- Après la mise en marche de l'appareil, les valeurs réglées en dernier s'affichent sur l'**écran (5)** (ill. 3).
- Dans ce menu, les fonctions Chauffage, Soufflerie et Entraînement sont désactivées.
- L'utilisateur peut ici procéder à l'aide des **éléments de commande (4)** à tous les réglages décrits dans les chapitres suivants.
- Cependant, si la température de l'élément chauffant est supérieure à 80 °C lors de la mise en marche, l'écran passe immédiatement en mode Refroidissement (chapitre 1.8 Refroidissement), dans lequel la soufflerie est toujours actionnée à la puissance maximale et refroidit ainsi la **buse de soudage (9)**. Il est possible à tout moment de revenir au mode de travail à partir de ce mode en appuyant sur le bouton e-Drive .
- Si la température de l'élément chauffant atteint 60 °C lors du refroidissement, la soufflerie continue de fonctionner 2 minutes puis s'arrête ensuite automatiquement. L'**écran (5)** revient à l'affichage des valeurs de consigne (ill. 3).
- Si vous tournez le bouton e-Drive  sur Profil, vous pouvez sélectionner les différents profils de soudage (ill. 4 ; chapitre 1.7 Sélection des profils).

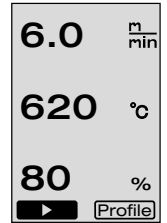





(ill. 3)



(ill. 4)

1.2 Affichage de travail

- Appuyez sur le bouton e-Drive  pour démarrer le chauffage et la soufflerie : l'écran passe de l'affichage des valeurs de consigne à l'affichage du mode de travail.
- Le chauffage de la **buse de soudage (9)** est indiqué sur l'**écran (5)** au moyen d'une barre de progression, d'une flèche ▲ (vers le haut) et de la valeur réelle de la température de soudage (clignotant) (ill. 5).
Si la valeur de consigne de la température de soudage est atteinte, la flèche et la barre de progression ne sont plus affichées (ill. 6).
- Si la tension du secteur se situe hors (+/- 15 %) de la plage de tension nominale indiquée, le symbole s'affiche en alternance avec la sous-tension  /surtension  mesurée ou avec la quantité d'air réglée. Si la quantité d'air est égale à 100 %, le symbole clignote et la sous-tension  /surtension  mesurée s'affiche (ill. 7). (possible uniquement pour VARIANT T1 230 V~).

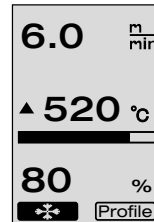

(ill. 5)

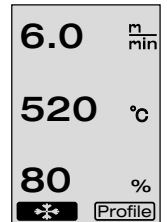

(ill. 6)

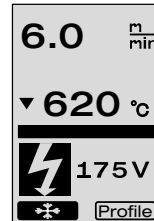

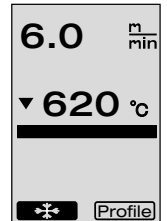

(ill. 7)



(ill. 8)



Une sous-tension/surtension peut avoir des répercussions sur le résultat du soudage !







- Si aucune touche n'est enfoncée au bout d'une durée définie (**buse de soudage (9)** PAS en position de soudage), le menu Veille s'affiche (chapitre 1.9 Veille).
- Si la **buse de soudage (9)** ne se trouve pas en position d'arrêt, les menus Refroidissement (chapitre 1.8 Refroidissement) ou Profils (chapitre 1.7 Sélection des profils) peuvent être sélectionnés en tournant le bouton e-Drive .
- Si la **buse de soudage (9)** est rentrée, les deux points de menu  Profile disparaissent de l'**écran (5)** et ne peuvent plus être sélectionnés.
- Le refroidissement de la **buse de soudage (9)** est indiqué par une barre de progression remplie, une flèche ▼ (vers le bas) et la valeur réelle de la température de soudage clignotant à l'**écran (5)** (ill. 8).

1. Mode de travail

1.3 Réglage de la vitesse d'entraînement

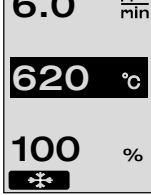



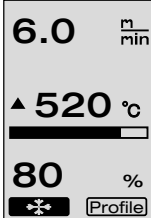

- La vitesse d'entraînement peut être réglée à l'aide de la touche Entraînement  . Elle peut être réglée par pas de 0,1 m/min sur une plage de 1,5 m/min – 18,0 m/min en tournant le bouton e-Drive  . Ce réglage peut être effectué avec un entraînement activé ou désactivé. Si aucune saisie n'est effectuée au bout de 3 secondes au moyen des **éléments de commande (4)**, la nouvelle vitesse d'entraînement est prise en compte. L'affichage des valeurs de consigne ou Refroidissement apparaît à l'écran (5) (ill. 9).
- Si la **buse de soudage (9)** n'est pas en position de soudage, le symbole  (Démarrage) apparaît en bas à gauche de l'écran (5).
- L'entraînement peut être activé en appuyant sur le bouton e-Drive  , et le symbole  (Arrêt) apparaît. La vitesse d'entraînement peut être réglée directement en tournant le bouton e-Drive  .
- Si vous appuyez une nouvelle fois sur le bouton e-Drive  , l'instruction Arrêt est exécutée et l'entraînement est mis hors circuit. L'affichage des valeurs de consigne ou Refroidissement apparaît à l'écran.
- Si vous appuyez sur la touche Entraînement  pendant 3 secondes, l'affichage passe à un autre menu (voir chapitre 1.6 Mesure des longueurs, compteurs de soufflerie et d'entraînement).
- Vous pouvez accéder au menu correspondant au moyen des touches Chauffage  ou Soufflerie  .

1.4 Réglage de la température de soudage

- La température de soudage peut être modifiée à l'aide de la touche Chauffage  . Vous pouvez régler la température de soudage par pas de 10 °C sur une plage de 100 °C – 620 °C en tournant le bouton e-Drive  . Le réglage est pris en compte au bout de 3 secondes, pour autant qu'aucune touche n'ait été actionnée pendant ces 3 secondes (ill. 10).
- Si vous appelez ce menu à partir de l'affichage des valeurs de consigne, vous pouvez démarrer le chauffage et la soufflerie en appuyant sur le bouton e-Drive  . Si le chauffage est activé, vous pouvez sélectionner le menu Refroidissement (chapitre 1.8 Refroidissement) (ill. 11).
- Si vous appuyez sur la touche Chauffage  pendant 3 secondes, la tension du secteur s'affiche en dessous de la vitesse d'entraînement. Vous pouvez appeler cette fonction uniquement à partir de l'affichage de travail (chapitre 1.2). (possible uniquement pour VARIANT T1 230 V~).
- Vous pouvez accéder au menu correspondant au moyen des touches Entraînement  ou Soufflerie  .

1. Mode de travail



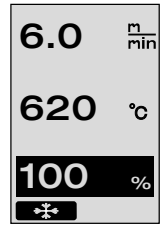

1.5 Réglage de la quantité d'air

- La quantité d'air peut être modifiée à l'aide de la touche Soufflerie . Vous pouvez régler la quantité d'air par pas de 5 % sur une plage de 40 % – 100 % en tournant le bouton e-Drive . Le réglage est pris en compte au bout de 3 secondes, pour autant qu'aucune touche n'ait été actionnée pendant ces 3 secondes. Si la quantité d'air est réglée sur 100 %, rien ne s'affiche à l'écran (5) (ill. 12).
- Si vous appelez ce menu à partir de l'affichage des valeurs de consigne, vous pouvez démarrer le chauffage et la soufflerie en appuyant sur le bouton e-Drive .
- Vous pouvez sélectionner le menu Refroidissement en appuyant sur le bouton e-Drive  (chapitre 1.8 Refroidissement).
- Vous pouvez accéder à chaque menu correspondant au moyen des touches Entraînement  ou Chauffage .



(ill. 12)

1.6 Mesure des longueurs, compteurs de soufflerie et d'entraînement



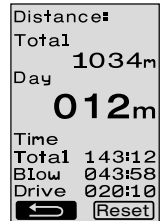







- Ce menu (ill. 13) s'affiche si vous maintenez la touche Entraînement  enfoncée pendant au moins 3 secondes.
- Ce menu indique tous les temps de fonctionnement et la distance parcourue par l'appareil depuis sa mise en marche. La distance totale (ici : 1034 m) ne peut pas être modifiée et correspond à la distance totale parcourue depuis la mise en service.
- La distance journalière (ici : 012 m) n'est pas automatiquement réinitialisée ; ceci doit être effectué par l'utilisateur via la fonction **Reset** en appuyant sur le bouton e-Drive .
- Les valeurs Time correspondent au temps de fonctionnement de chaque composant de l'appareil. Le temps de la soufflerie «Blow» (ici : 043:58) et celui de l'entraînement « Drive » (ici : 020:10) sont affectés ici. Le temps « Total » se rapporte au temps de fonctionnement. Il comptabilise les heures et les minutes (ici : 143:12) pendant lesquelles le **commutateur principal (3)** est activé.
- Si vous sélectionnez la flèche Retour  en appuyant sur le bouton e-Drive , vous accédez de nouveau au menu dans lequel vous avez appuyé sur la touche Entraînement .



(ill. 13)

1. Mode de travail

1.7 Sélection des profils

- Si l'indication **Profile** à droite en bas de l'écran (5) est activée, vous pouvez charger des profils en appuyant sur le bouton e-Drive . L'indication « Select Profile » s'affiche ensuite. Vous pouvez sélectionner un profil en tournant le bouton e-Drive . Les profils FREE 1–7 peuvent être définis par l'utilisateur (voir chapitre 2 Configuration du profil). Des valeurs fixes sont attribuées à tous les autres profils et ne peuvent pas être définies par l'utilisateur (ill. 14).
- En tournant le bouton e-Drive , vous pouvez activer les flèches vers la gauche ou la droite situées en bas de l'écran (5).
Flèche vers la droite  tout en appuyant sur le bouton e-Drive  : passage à la page suivante (ill. 15).
Flèche vers la gauche  tout en appuyant sur le bouton e-Drive  : passage à la page précédente (ill. 16).
- Si vous actionnez la flèche Retour  tout en tournant le bouton e-Drive , vous retournez au menu dans lequel vous avez sélectionné le menu Profil, en appuyant sur le bouton e-Drive  (ill. 15).

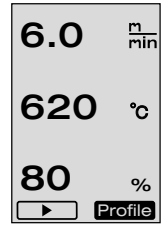

(ill. 14)

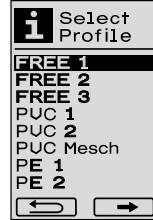

(ill. 15)

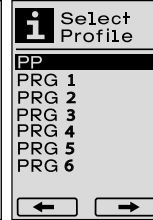



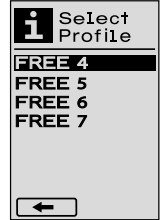



(ill. 16)



Procédez à un essai de soudage conformément aux instructions de soudage du fabricant de matériaux et aux normes ou directives nationales. Contrôlez l'essai de soudage.

1.8 Refroidissement

- Si vous sélectionnez le symbole  en appuyant sur le bouton e-Drive  (ill. 17), le menu « Cool down OK? » s'affiche (ill. 18). Si vous appuyez sur le bouton e-Drive , le symbole OK est activé en bas à droite de l'écran (5). Le processus de refroidissement est ainsi déclenché.
- Pendant le processus de refroidissement, la quantité d'air est augmentée à 100 % et la température de soudage actuelle est affichée (ill. 19).
Si la température de soudage est inférieure à 60 °C, la soufflerie continue de fonctionner pendant 2 minutes et s'arrête automatiquement à la fin de ce délai. L'écran passe à l'affichage des valeurs de consigne.
- Si vous appuyez sur le bouton e-Drive  pendant le processus de refroidissement, le chauffage est démarré et l'affichage de travail s'affiche à l'écran (5) (voir chapitre 1.2 Affichage de travail).
- Si le menu Refroidissement est activé, l'entraînement peut être activé/désactivé manuellement à l'aide de la touche Entraînement . Les touches Chauffage  et Soufflerie  n'ont aucune fonction.

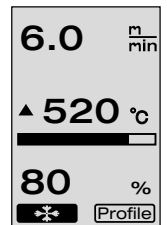

(ill. 17)

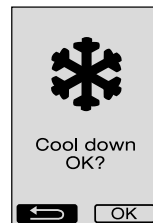

(ill. 18)

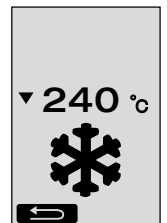

(ill. 19)

1. Mode de travail

1.9 Mode Veille

- Si la **buse de soudage (9)** ne se trouve pas en position de soudage et qu'aucune touche n'est activée pendant une durée de veille définie par l'utilisateur, le mode Refroidissement démarre automatiquement à la fin de la durée de veille (ill. 20). Le processus de refroidissement est déclenché.
- Si vous appuyez sur le bouton e-Drive avant la fin du compte à rebours (180 secondes), **l'écran (5)** revient à l'affichage de travail (voir chapitre 1.2 Affichage de travail).
- Réglage du temps de veille (chapitre 2.3 Configuration du mode Veille).

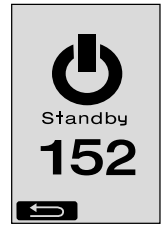

(ill. 20)

1.10 Messages d'erreur

- En cas de dysfonctionnement de la soudeuse automatique à air chaud VARIANT T1, un message s'affiche à **l'écran (5)**, suivi d'un code d'erreur. Ce code correspond à une description plus précise de l'erreur, visible dans la liste ci-dessous.
- Pour les erreurs 02 et 40, des symboles différents s'affichent.
- Pour toutes les autres erreurs, la clé indiquant de s'adresser au SAV s'affiche.



Erreur	Type d'erreur
Err00	Electronique de commande défectueuse
Err01	Coupeure ou court-circuit au niveau de la sonde de température
Err02	Elément chauffant/électronique défectueux (coupeure dans un/les enroulement(s))
Err04	Triac défectueux (un Triac est défectueux ou les deux)
Err08	Moteur de soufflerie défectueux
Err40	Sous-tension 25 % (tension du secteur 75 %), uniquement VARIANT T1 230 V~

2. Configuration du profil



























2.1 Combinaison de touches de configuration du profil

Maintenez les touches Entraînement et Chauffage enfoncées tout en positionnant le commutateur principal sur MARCHE



2. Configuration du profil

2.2 Création de profils

- 7 profils différents peuvent être créés dans Configuration du profil, dans lesquels le nom et les trois paramètres Entraînement , Chauffage , Soufflerie  peuvent être réglés librement puis enregistrés en appuyant sur le bouton e-Drive  (ill. 21).
- Les différents points de menu peuvent être sélectionnés à l'aide des **éléments de commande (4)**. Si vous appuyez sur le bouton e-Drive , vous retournez à la sélection de la configuration du profil.
- En tournant le bouton e-Drive , vous pouvez activer les flèches vers la gauche ou la droite situées en bas de l'écran (5).
Flèche vers la droite  tout en appuyant sur le bouton e-Drive  : passage à la page suivante (ill. 15).
Flèche vers la gauche  tout en appuyant sur le bouton e-Drive  : passage à la page précédente (ill. 16).
- Si le symbole  (ABC) est activé en tournant le bouton e-Drive , vous retournez au menu Nom du profil en appuyant sur le bouton e-Drive .
- Dans le menu Nom du profil, tournez le bouton e-Drive  pour sélectionner les symboles _ / . / A à Z / 0 à 9, ainsi que les flèches vers la gauche ou la droite et les symboles Enregistrer  ou Retour .
- Modifier le nom du profil
 - Tournez le bouton e-Drive  pour sélectionner les flèches vers la gauche ou la droite. Si la flèche vers la droite est activée en appuyant sur le bouton e-Drive , la position d'un symbole (noir) dans le nom du profil se déplace vers la droite. Si la flèche vers la gauche est activée en appuyant sur le bouton e-Drive , la position d'un symbole (noir) dans le nom du profil se déplace vers la gauche (ill. 23).
 - Si vous tournez le bouton e-Drive , le symbole souhaité (_ / . / A à Z / 0 à 9) peut être sélectionné. Si vous appuyez sur le bouton e-Drive , le symbole en noir dans le nom du profil est remplacé par le symbole que vous venez de sélectionner.
- Enregistrement ou rejet du nom du profil
 - Si le symbole Enregistrer  est sélectionné en tournant le bouton e-Drive , appuyez sur le bouton e-Drive  pour enregistrer le nom du profil.
 - Si le symbole Retour  est sélectionné en tournant le bouton e-Drive , appuyez sur le bouton e-Drive  pour rejeter le nom du profil (il ne sera pas enregistré).



(ill. 21)

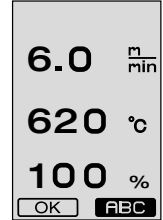
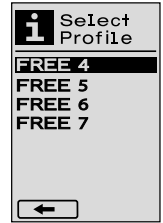

(ill. 22)





(ill. 23)



Procédez à un essai de soudage conformément aux instructions de soudage du fabricant de matériaux et aux normes ou directives nationales. Contrôlez l'essai de soudage.

2.3 Configuration du mode Veille

- Le temps de veille définit la durée devant s'écouler (aucune activation de touche, **buse de soudage (9)** pas en position de soudage) avant le déclenchement automatique du processus de refroidissement (voir chapitre 1.8 Refroidissement).
– Vous pouvez régler le temps de 5 – 120 minutes en tournant le bouton e-Drive . Le réglage en usine est 40 minutes.
- Si vous appuyez sur le bouton e-Drive , vous retournez à la sélection de la configuration du profil.

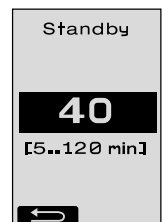

- La machine s'éteint automatiquement
 - En mode Veille, la machine s'éteint automatiquement après le temps réglé (réglage en usine : 40 minutes).
 - Si nécessaire, augmentez le temps de veille (page 69, chapitres 2. Configuration du profil et 2.3 Configuration du mode Veille).
- La qualité de la soudure est mauvaise
 - Contrôlez la vitesse d'entraînement, la température de soudage et la quantité d'air
 - Nettoyez la **buse de soudage (9)** avec la brosse métallique
 - Mauvais réglage de la **buse de soudage (9)**

Procédez au réglage de la buse de soudage (9) comme suit :

- Laissez refroidir la **buse de soudage (9)** (page 67, chapitres 1. Mode de travail et 1.8 Refroidissement)
- Desserrez les vis à six pans creux au niveau du support de l'appareil
- Effectuez l'ajustage angulaire au niveau de la **soufflerie à air chaud (8)** par petits mouvements oscillants.
- La **buse de soudage (9)** doit reposer sur le **calibre pour buses (34)** (flèche L) et sur le support (flèche R).
- Serrez les vis à six pans creux au niveau du support de l'appareil
- Positionnez le **calibre pour buses (34)**. Tenez compte de l'échelle sur le **calibre pour buses (34)**
- Placez la **soufflerie à air chaud (8)** en position de soudage
- Desserrez les **vis d'ajustage du pivot (25)**
- Alignez la **soufflerie à air chaud (8)** parallèlement au **calibre pour buses (34)**
- Serrez les **vis d'ajustage du pivot (25)**
- Retirez le **calibre pour buses (34)** et procédez à un essai de soudage.

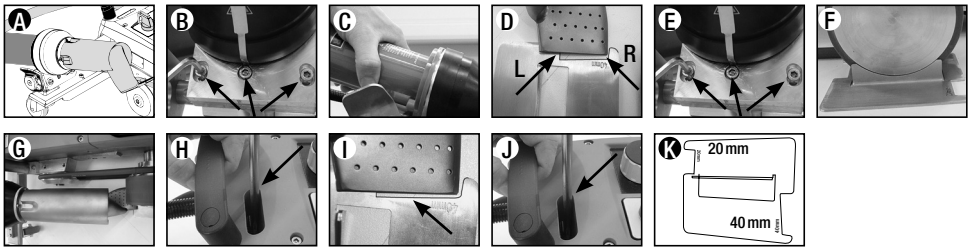

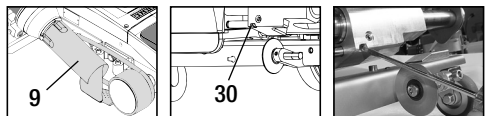

- La température réglée n'est pas atteinte (l'affichage de la température clignote)
 - Contrôlez la tension du secteur
 - Réduisez la quantité d'air
 - Réduisez la température
- La soufflerie à air chaud ne s'arrête pas en position de soudage
 - Réglez la pièce de bille de pression comme suit :
 - Laissez refroidir la **buse de soudage (9)** (page 67, chapitres 1. Mode de travail et 1.8 Refroidissement)
 - Placez la **buse de soudage (9)** en position de soudage
 - A l'aide d'un tournevis, serrez légèrement la **vis (30)**, puis tournez la **vis (30)** d'environ 1/2 tour dans le sens inverse.

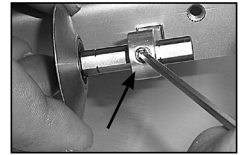
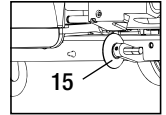
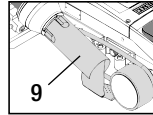

- La largeur de soudure n'est pas constante
 - Procédez au réglage précis du rouleau de guidage comme suit :
 - Laissez refroidir la **buse de soudage (9)** (page 67, chapitres 1. Mode de travail et 1.8 Refroidissement)
 - Placez la **buse de soudage (9)** en position de soudage
 - Desserrez la vis à six pans creux du **rouleau de guidage (15)**
 - Poussez le **rouleau de guidage (15)** dans la position souhaitée
 - Serrez la vis à six pans creux
 - Procédez à un essai de soudage





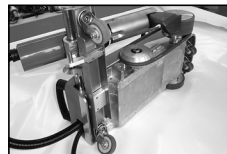
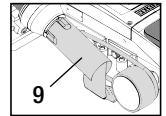
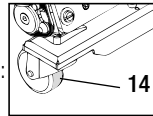

- La soudeuse automatique à air chaud s'éloigne du soudure (soudage par recouvrement)
 - Procédez au réglage précis du tracé de la **poulie de guidage (14)** comme suit :
 - Laissez refroidir la **buse de soudage (9)** (page 67, chapitres 1. Mode de travail et 1.8 Refroidissement)
 - Mettez le **commutateur principal (3)** hors circuit **OFF** 
 - Débranchez le câble d'alimentation secteur du secteur électrique 
 - Retirez le **poids supplémentaire (16)**
 - Basculez la soudeuse automatique sur le côté
 - Desserrez la **vis d'arrêt pour le réglage précis du tracé (31)** et poussez le **levier de réglage précis du tracé (32)** en position souhaitée
 - Serrez la **vis d'arrêt pour le réglage précis du tracé (31)**
 - Placez la soudeuse automatique à air chaud en position de soudage
 - Positionnez le **poids supplémentaire (16)**
 - Remettez la soudeuse automatique à air chaud en marche
 - Procédez à un essai de soudage

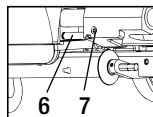
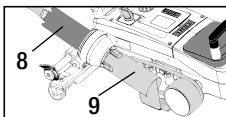

- Le dispositif automatique de démarrage ne fonctionne pas
Si le moteur d'entraînement ne démarre pas automatiquement après l'insertion de la **buse de soudage (9)**, le **capteur de démarrage (6)** est peut-être mal réglé.
 - Réglez le **capteur de démarrage (6)** comme suit :
 - Laissez refroidir la **buse de soudage (9)** (page 67, chapitres 1. Mode de travail et 1.8 Refroidissement)
 - Mettez le **commutateur principal (3)** hors circuit **OFF** 
 - A l'aide de la **soufflerie à air chaud (8)**, placez la **buse de soudage (9)** en position de soudage et enclenchez-la.
 - Procédez au réglage du **capteur de démarrage (6)** au niveau de la **vis sans tête (7)** à l'aide d'une clé Allen ; **IMPORTANT : portée : 0,2 – 0,5 mm**
 - Contrôlez le fonctionnement



Si le moteur d'entraînement ne démarre toujours pas automatiquement, contactez le SAV.

	Par recouvrement	Ourlet	Ourlet à jour (jusqu'à 70 mm)	Cordon de ralingue	Ralingue prédéfinie
	●	●	●		
		●	●	●	
		●		●	●
				●	●

Application

A la place du rouleau de guidage (15), il est également possible d'utiliser la pièce d'assemblage ourlet/ralingue.

Egalement possible avec modèle standard et fixation de bêche.

Egalement possible avec modèle standard et fixation de bêche.

Surface avec rainure longitudinale pour ralingue recommandée.

Fixation sans pli des ralingues prédéfinies.

Type

Bonne fixation de la bêche.

Marquage du recouvrement d'ourlet pour un meilleur contrôle du guidage.

Marquage du recouvrement d'ourlet pour un meilleur contrôle du guidage.

Marquage du recouvrement d'ourlet pour un meilleur contrôle du guidage. Marche à vide de l'appareil, guidage manuel de la bêche avec ralingue

Modèles Leister VARIANT T1

- Réf. 141.891 VARIANT T1, 230 V / buse de soudage 40 mm / avec prise européenne
Réf. 141.892 VARIANT T1, 230 V / buse de soudage 20 mm / avec prise européenne
Réf. 141.893 VARIANT T1, 400 V / buse de soudage 40 mm / avec prise EURO (3LNPE)
Réf. 141.894 VARIANT T1, 400 V / buse de soudage 20 mm / avec prise EURO (3LNPE)
Réf. 147.739 VARIANT T1, 200 V / buse de soudage 40 mm / sans prise
Réf. 147.748 VARIANT T1, 200 V / buse de soudage 20 mm / sans prise

Accessoires

Pour des raisons techniques et de sécurité, seuls des accessoires Leister doivent être utilisés.

- | | |
|---|--|
| Réf. 142.650 Kit ourlet/ralingue complet | Réf. 139.438 Poids supplémentaire |
| Réf. 140.530 Pièce d'assemblage ourlet/ralingue | Réf. 137.843 Partie supérieure de la manette de guidage (poignée en T) |
| Réf. 142.221 Serre-flan | Réf. 116.798 Brosse en laiton |
| Réf. 141.326 Guide de ralingue | Réf. 142.705 Malette d'outils |

Formation

- Leister Technologies AG et ses SAV compétents proposent des cours et des formations de soudage gratuits. Informations à l'adresse www.leister.com.

Entretien

- L'entrée d'air de la **soufflerie à air chaud (8)** doit être nettoyée des impuretés à l'aide d'un pinceau → 
- Nettoyez la **buse de soudage (9)** avec la brosse en laiton
- Contrôlez le **câble d'alimentation secteur (1)** et la prise à la recherche de dommages électriques et mécaniques

Maintenance et réparation

- Si le compteur d'entraînement atteint 400 h ou le compteur de soufflerie 2000 h, le message « **Maintenance servicing** » s'affiche à l'**écran (5)** à la prochaine mise en marche du **commutateur principal (3)**. Ce message s'affiche pendant 10 secondes et ne peut pas être ignoré au moyen des **éléments de commande (4)**.
- Les réparations doivent être réalisées exclusivement par les **SAV Leister** compétents. Ils garantissent un **service de réparation** approprié et fiable **sous 24 heures** avec des pièces détachées d'origine, conformément aux schémas de câblage et aux listes des pièces de rechange.

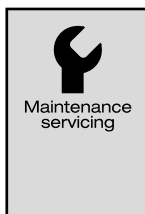

Garantie

- Les droits de garantie fabricant et de garantie légale accordés par le partenaire commercial ou vendeur direct s'appliquent à cet appareil à compter de la date d'achat. En cas de recours à la garantie (justificatif par la facture ou le bordereau de livraison), les défauts de fabrication ou d'usure seront supprimés par le partenaire commercial qui procédera à une fourniture en remplacement ou à une réparation. Les éléments chauffants sont exclus de la garantie.
- Toute autre prétention à la garantie fabricant ou à la garantie légale dans le cadre du droit en vigueur est exclue.
- Les dommages résultant d'une usure naturelle, d'une surcharge ou d'un traitement non conforme sont exclus de la garantie.
- Aucun droit de revendication n'est accordé pour les appareils qui auront été transformés ou modifiés par l'acheteur.

Enhorabuena por adquirir una soldadora automática de aire caliente VARIANT T1

Se ha decidido por una soldadora automática de aire caliente de primera clase, compuesta por materiales de calidad. Este equipo se ha desarrollado y fabricado conforme a las técnicas de soldadura más modernas. Todos los VARIANT T1 se someten a un estricto control de calidad antes de salir de la fábrica de Suiza.

Índice

Aplicación, advertencias, precauciones	Página	75
Conformidad, eliminación, datos técnicos	Página	76
Descripción del equipo, elementos de manejo	Página	77
Iconos informativos, iconos activos, información rápida	Página	78
Disponibilidad operativa, posicionamiento del equipo	Página	79
Proceso de soldadura	Página	80
Transporte, combinaciones de teclas	Página	81
Modo de trabajo (capítulo 1)		
1.1 Indicadores de valores nominales		
1.2 Indicadores de trabajo	Página	82
1.3 Ajuste de la velocidad de accionamiento		
1.4 Ajuste de la temperatura de soldadura	Página	83
1.5 Ajuste de la cantidad de aire		
1.6 Medición de extensión, contador de accionamiento y contador de soplador	Página	84
1.7 Selección de perfil		
1.8 Enfriamiento	Página	85
1.9 Standby		
1.10 Mensajes de error		
Configuración de perfiles (capítulo 2)		
2.1 Combinación de teclas para configuración de perfiles	Página	86
2.2 Creación de un perfil		
2.3 Configuración de Standby	Página	87
Preguntas frecuentes	Página	88/89
Aplicaciones de soldadura	Página	90
Modelos, accesorios, formación, mantenimiento, servicio y reparación, garantía	Página	91



Lea las instrucciones de funcionamiento atentamente antes de la puesta en funcionamiento y consérvelas para el futuro.

Leister VARIANT T1 Soldadora automática de aire caliente

Aplicación

Este equipo debe utilizarse únicamente en espacios con buena ventilación. En caso necesario, se debe trabajar con un dispositivo de aspiración o un equipamiento de protección personal. Asegúrese de que, durante los procesos de soldadura, el material no se queme. Compruebe con el fabricante de materiales todo lo relativo a los aditivos perjudiciales para la salud. Se deben aplicar las disposiciones legales relativas a la protección sanitaria del país.

- Soldadora automática de aire caliente guiada manualmente para costuras de soldadura a solape, de rebordes y burletes de material de lonas (PVC y materiales similares).
- **El procesamiento sólo se debe realizar en espacios bien ventilados**



Advertencia



Existe **peligro de muerte** al abrir el equipo, ya que se dejan al descubierto componentes y conexiones sometidos a tensión. Antes de abrir el equipo, desconecte el enchufe.



Peligro de fuego y explosiones en caso de un uso inadecuado de los dispositivos de aire caliente, en especial cerca de materiales inflamables y gases explosivos.



¡Peligro de quemaduras! No toque la boquilla de soldadura si está caliente. Espere a que el equipo se enfríe. No dirija el chorro de aire caliente hacia personas o animales.



Conecte el equipo a una **toma de corriente con un conductor de protección**. Los cortes del conductor de protección, ya se produzcan dentro o fuera del equipo, son peligrosos. **Utilice únicamente cables alargadores con conductor de protección.**



Precaución



La tensión indicada en el aparato, debe coincidir con la tensión del suministro de corriente eléctrica. EN 61000-3-11; $Z_{max} = 0.164 \Omega + j 0.102 \Omega$. En caso necesario, consulte a la empresa de suministro eléctrico. Extraiga el soplante de aire caliente si hay una interrupción de la corriente.



Es imprescindible un **interruptor FI** para el empleo del equipo, a modo de protección personal.



El equipo **debe permanecer vigilado** mientras esté funcionando. El calor puede llegar a materiales inflamables que se encuentren fuera del ámbito visual.

El equipo solo podrá ser utilizado por **personal especializado debidamente formado** o bajo su vigilancia. Se prohíbe terminantemente su uso por parte de niños.



Proteger el equipo **de la humedad y el agua**.



El equipo no se debe levantar por el peso adicional.

Conformidad

Leister Technologies AG, Galileo-Strasse 10, CH-6056 Kaegiswil/Suiza declara que este producto, en la versión que hemos introducido en circulación, cumple los requisitos de las siguientes directivas de la UE.

Directivas: 2006/42/EC, 2014/30/EU, 2011/65/EU

Normas armonizadas: EN ISO 12100, EN 55014-1, EN 55014-2, EN 61000-3-2, EN 61000-3-3, EN 61000-3-11 (Z_{max}), EN 61000-6-2, EN 62233, EN 60335-1, EN 60335-2-45, EN IEC 63000

Kaegiswil, 05.11.2020

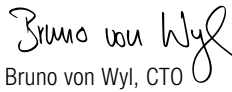
Bruno von Wyl, CTO



Christoph Baumgartner, GM

Eliminación



Los equipos eléctricos, los accesorios y los embalajes deben reciclarse y reutilizarse de forma adecuada para proteger el medio ambiente. No desechar jamás equipos eléctricos en la basura doméstica.

Datos técnicos

Tensión	V~	200	230	400 (2LNPE)	V~	200	230	400 (2LNPE)
Potencia	W	4200	3680	5700	W	4200	3680	5700
Frecuencia	Hz	50/60			Hz	50/60		
Temperatura	°C	100 – 620 sin escalas			°F	212 – 1148 sin escalas		
Velocidad	m/min	1,5 – 18 sin escalas			ft/min	4,9 – 59,1 sin escalas		
Cantidad de aire	%	40 – 100			%	40 – 100		
Nivel de emisiones	L_{pA} (dB)	70			L_{pA} (dB)	70		
Peso	kg	22			lbs	48,5		
sin cable de conexión de red								
Dimensiones L × AN × A	mm	500 × 400 × 195			pulgadas	19,7 × 15,8 × 7,7		
Símbolo de conformidad		CE				CE		
Clase de protección I								
Tensión de alimentación no conmutable								
Sujeto a modificaciones técnicas								

Descripción del equipo

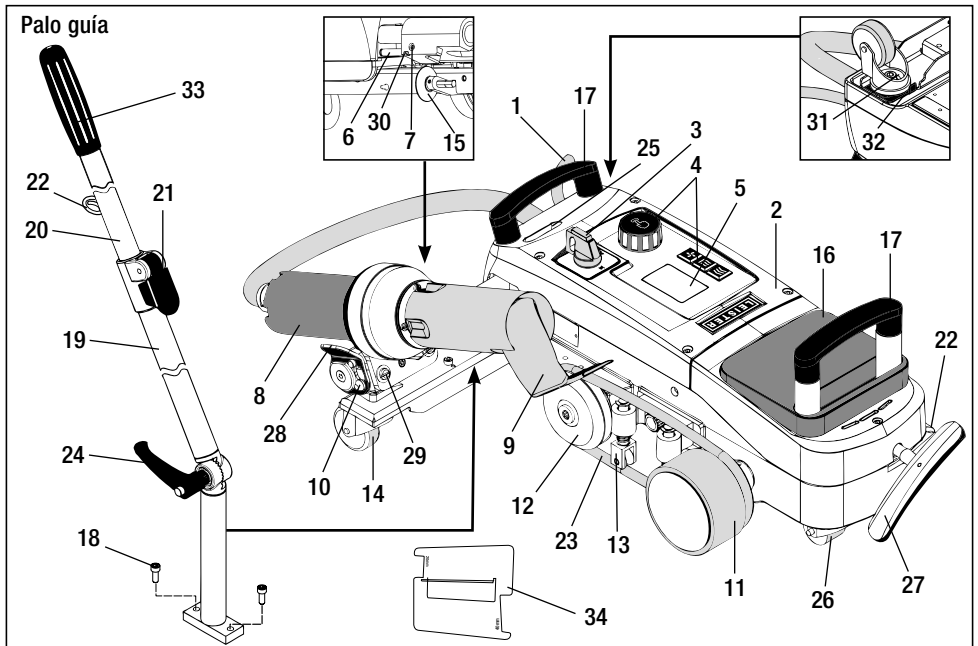

- | | | |
|---|---|---|
| 1 Cable de conexión de red | 12 Polea de inversión | 24 Tornillo de palanca de la parte inferior del palo guía |
| 2 Carcasa | 13 Pulsador | 25 Tornillo de ajuste del eje pivotante |
| 3 Interruptor principal | 14 Rodillo de dirección | 26 Rodillo de transporte |
| 4 Elementos de manejo | 15 Rodillo guía | 27 Mango para el dispositivo de elevación |
| 5 Pantalla | 16 Peso adicional | 28 Asidero |
| 6 Sensor de arranque | 17 Asa de transporte | 29 Ajuste angular del soporte |
| 7 Tornillo de sujeción para ajuste del sensor de arranque | 18 Tornillo cilíndrico | 30 Tornillo de tope para posición de soldadura |
| 8 Soplante de aire caliente | 19 Parte inferior de palo guía | 31 Tornillo de tope para ajuste preciso de trazado |
| 9 Boquilla de soldadura | 20 Parte superior de palo guía | 32 Palanca para ajuste preciso de trazado |
| 10 Talón de tope para soplante de aire caliente | 21 Palanca de sujeción de la parte superior del palo guía | 33 Mango del palo guía |
| 11 Rodillo de presión | 22 Soporte para cable de conexión de red | 34 Calibrador de boquillas |
| | 23 Correa | |

Interruptor principal (3)



Para conectar o desconectar la soldadora automática de aire caliente VARIANT T1

Elementos de manejo (4)



e-Drive

El e-Drive se utiliza como navegador.

Tiene dos funciones:



Girar a la izquierda o a la derecha para ajustar distintos menús o valores



Presionar para confirmar o activar



Accionamiento

Ajuste de la velocidad de accionamiento



Calefacción

Ajuste de la temperatura de soldadura



Soplante

Ajuste de la cantidad de aire

Iconos informativos

Los siguientes iconos muestran información en la pantalla.



La boquilla de soldadura se enfría



Equipo en modo Standby, se desconectará tras el proceso



Ponerse en contacto con el punto de servicio autorizado



Indica que la temperatura está aumentando



Indica que la temperatura está disminuyendo



Barra de proceso

Iconos activos

Los siguientes iconos se mostrarán en la pantalla y se activarán al pulsar e-Drive.



Conexión de la calefacción y el soplante (en caso de que el soplante aún no esté en marcha)



Detención del accionamiento



Inicio del accionamiento



Enfriamiento automático (calefacción OFF, soplante ON)



En la estructura hacia arriba (volver al programa anterior)



Enter, confirmar



Seleccionar perfil



Guardar nuevo nombre



Modificar nombre de perfil



Ir a la página siguiente



Ir a la página siguiente



Poner a cero la distancia diaria

Iconos informativos



Iconos activos

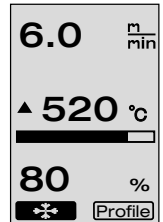
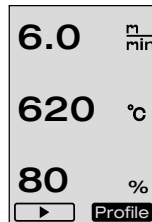

Información rápida

Cómo poner en marcha la soldadora automática de aire caliente VARIANT T1

1. Conectar el cable de conexión de red a la red eléctrica

2. Interruptor principal (3) ON

3. Pulsar la tecla de accionamiento



4. Pulsar la tecla de calefacción

5. Pulsar la tecla de soplante



6.0 $\frac{m}{min}$

620 °C

100 %

girar e-Drive

girar e-Drive

girar e-Drive

6. Pulsar e-Drive Tiempo de calentamiento aprox. 1–2 minutos

7. Realizar una soldadura de prueba conforme a las instrucciones de soldadura del fabricante del material y las normas o directivas nacionales. Comprobar la soldadura de prueba.

8. Soldadura

Cómo desconectar la soldadora automática de aire caliente VARIANT T1

1. Pulsar e-Drive (fig. 1).

2. Pulsar e-Drive en «Cool down OK» y dejar enfriar durante aprox. 4 minutos (fig 2). El soplante se desconecta automáticamente.

3. Tras el enfriamiento de la boquilla de soldadura (9), apagar el interruptor principal (3) OFF

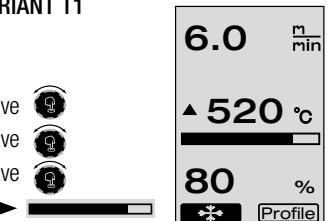

(Fig. 1)

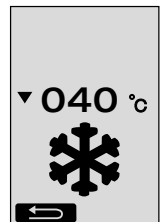

(Fig. 2)

Disponibilidad operativa

- Antes de la puesta en funcionamiento, controlar que el cable de **conexión de red (1)** y el enchufe, así como el alargador, no tengan daños mecánicos ni eléctricos.
- Los ajustes básicos de la **boquilla de soldadura (9)** se realizan en fábrica
- Controlar el ajuste básico de la **boquilla de soldadura (9)**
 - El control se puede realizar con el **calibrador de boquillas (34)** o conforme a los detalles A y B.

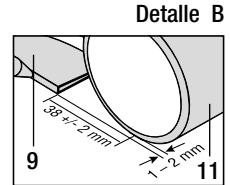
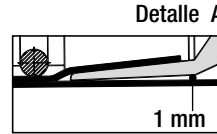
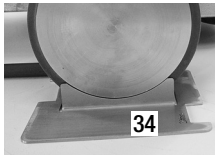

- Montar el **palo guía** con los **tornillos cilíndricos (18)**.
 - Colocar en la posición deseada la **parte inferior del palo guía (19)** con el **tornillo de palanca (24)** y la **parte superior del palo guía (20)** con la **palanca de sujeción (21)**.
 - Colocar el elemento de descarga de tracción del **cable de conexión de red (1)** en el **soporte (22)** en el palo guía o en el chasis.

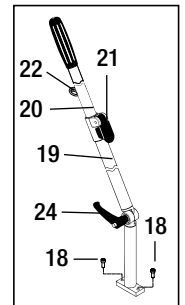

- Colocar **peso adicional (16)** (máx. dos pesos adicionales)

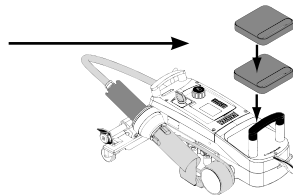

Conectar el equipo a la tensión nominal. La tensión nominal indicada en el equipo debe coincidir con la tensión de red.

En caso de **fallo de la alimentación**, desplazar el **soplante de aire caliente (8)** a la posición de parada.

Posicionamiento del equipo

- El material de lona debe estar limpio entre el solape y la parte superior e inferior.
- La **boquilla de soldadura (9)**, el **rodillo de presión (11)**, la **polea de inversión (12)** y la **correa (23)**, así como el **pulsador (13)**, deben estar limpios.
- Si la soldadora automática de aire caliente no está lista para el transporte, levantarla con el **mango (27)** del dispositivo de elevación. Los **rodillos de transporte (26)** funcionarán ahora.
- Desplazar la soldadora automática de aire caliente a la posición de soldadura.
- Con el **mango (27)**, descender la soldadora automática de aire caliente a la posición de soldadura. Los **rodillos de transporte (26)** ya no funcionarán y, por tanto, se descargarán.
- Bajar el **rodillo guía (15)**
- El **rodillo guía (15)** debe estar paralelo al **rodillo de presión (11)** (detalle C).

Listo para el transporte
Mango hacia la izquierda

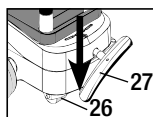

Posición de soldadura
Mango hacia la derecha

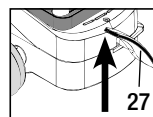

Detalle C

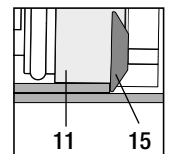

Proceso de soldadura

• Preparación



Realizar una soldadura de prueba conforme a las instrucciones de soldadura del fabricante del material y las normas o directivas nacionales. Comprobar la soldadura de prueba.

- Ajustar los parámetros de soldadura de accionamiento, calefacción y soplante (capítulo 1, modo de trabajo)
- Debe haberse alcanzado la temperatura de soldadura (tiempo de calentamiento aprox. 1–2 min.)

• Inicio de la soldadura





- Bajar el **rodillo guía (15)**
- Girar hacia abajo e introducir ligeramente el **soplante de aire caliente (8)** hasta que el **talón de tope (10)** salga del orificio. Bajar inmediatamente el **soplante de aire caliente (8)**.



ATENCIÓN: Si se introduce y baja demasiado el **soplante de aire caliente (8)**, las **boquillas de soldadura (9)** y el **rodillo de presión (11)** entrarán en contacto. Por lo tanto, no se podrá bajar tanto el **soplante de aire caliente (8)**.

- El material de lona superior en el área del rodillo guía se deberá levantar ligeramente y, desplazando el **soplante de aire caliente (8)**, encajar la **boquilla de soldadura (9)** hasta el tope entre las lonas solapadas.



- El motor de accionamiento arrancará automáticamente. Si no se produce el arranque automático, consulte el capítulo Preguntas Frecuentes, página 89.
- La máquina se puede iniciar manualmente con los elementos de manejo de accionamiento  y e-Drive .
- Si se inicia el accionamiento con  y el e-Drive  y se introduce a continuación la **boquilla de soldadura (9)**, la soldadora automática de aire caliente continúa su marcha tras girar la **boquilla de soldadura (9)** hacia afuera aprox. 30 cm (retardo de la desconexión del accionamiento).
- La soldadora automática de aire caliente se puede guiar por el solape con el **mango del palo guía (33)**, el **asa de transporte (17)** o el **asidero (28)**. Guíe la soldadora automática de aire caliente sin presión con el **mango del palo guía (33)**, el **asa de transporte (17)** o el **asidero (28)** durante el proceso de soldadura. Si ejerce demasiada presión, pueden producirse fallos en la soldadura. Preste atención a la posición del **rodillo guía (15)**.

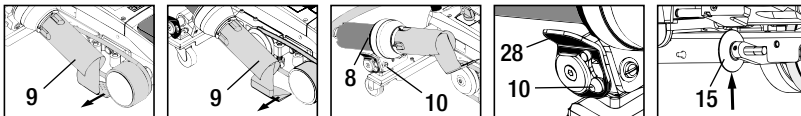

• Finalización de la soldadura

- Tras la soldadura, desplazar la **boquilla de soldadura (9)** con el **soplante de aire caliente (8)** hacia la derecha de la posición de soldadura y levantarla.
- Desplazar el **soplante de aire caliente (8)** hacia la derecha hasta que el **talón de tope (10)** encaje en el orificio del **asidero (28)**. El **soplante de aire caliente (8)** se encuentra en la posición de parada.
- Subir el **rodillo guía (15)**

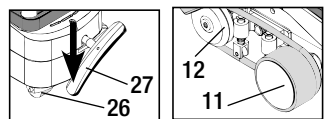

- Bajar los **rodillos de transporte (26)** girando el **mango (27)**. De esta forma, se descargarán el **rodillo de presión (11)** y la **polea de inversión (12)** para el transporte.



- Tras finalizar los trabajos de soldadura, desconectar la calefacción con el e-Drive   (presionar dos veces), de esta forma, se enfriará la **boquilla de soldadura (9)** y se desconectará la soldadora automáticamente después de aprox. 4 minutos (capítulo 1.8, Enfriamiento).
- Apagar el **Interruptor principal (3)** 



Desconectar el cable de conexión de red de la red eléctrica.

- Limpiar la **boquilla de soldadura (9)** con un cepillo de latón

Transporte

- Subir el **rodillo guía (15)**.
- Desplazar el **soplante de aire caliente (8)** hacia la derecha hasta que el **talón de tope (10)** encaje en el orificio del **asidero (28)**. El **soplante de aire caliente (8)** se encuentra en la posición de parada.
- Bajar los **rodillos de transporte (26)** girando el **mango (27)**. De esta forma, se descargarán el **rodillo de presión (11)** y la **polea de inversión (12)** para el transporte.

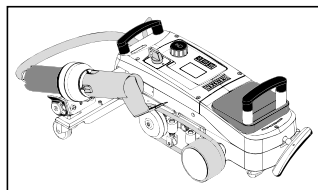
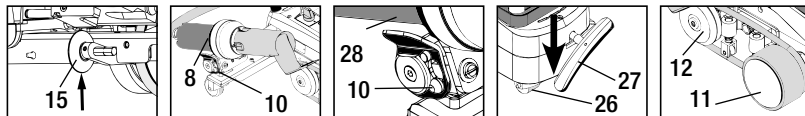

Desplazamiento



Transporte

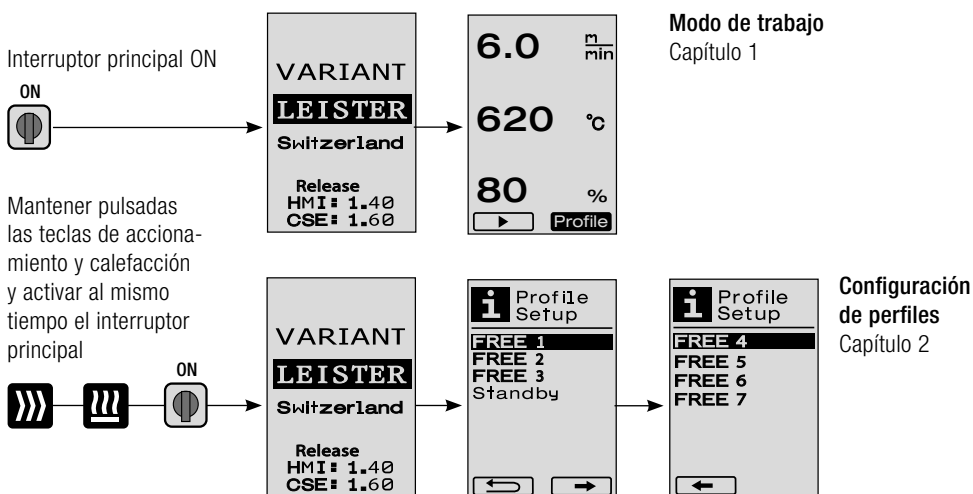

Combinaciones de teclas



1. Modo de trabajo

1.1 Indicadores de valores nominales (tras conectar el equipo)

Interruptor principal (3) ON 

- Tras conectar el equipo, aparecerán en la **pantalla (5)** los últimos valores ajustados (fig. 3).
- En este menú, están desconectados la calefacción, el soplante y el accionamiento.
- El usuario puede realizar aquí con los **elementos de manejo (4)** todos los ajustes descritos en los siguientes capítulos.
- Si la temperatura del elemento calentador es superior a 80 °C al conectarlo, el indicador cambia inmediatamente al modo Cool Down (capítulo 1.8 Enfriamiento) en el que el soplante funciona a pleno rendimiento y se enfría, de este modo, la **boquilla de soldadura (9)**. En este modo, pulsando e-Drive , se puede cambiar siempre de nuevo al modo de trabajo.
- Cuando la temperatura del elemento calentador llegue se enfríe hasta 60 °C, el soplante seguirá funcionando durante 2 minutos y se desconectará después automáticamente. La **pantalla (5)** vuelve a los indicadores de valores nominales (fig. 3).
- Girando el e-Drive  a Profile, se pueden seleccionar los diferentes perfiles de soldadura (fig. 4; Capítulo 1.7, Selección de perfil).

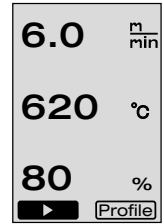

(Fig. 3)



(Fig. 4)

1.2 Indicador de trabajo



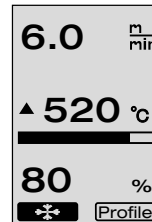

- Al pulsar el e-Drive  se inician la calefacción y el soplante y los indicadores de valores nominales cambian a los indicadores de trabajo.
- Durante el calentamiento de la **boquilla de soldadura (9)**, este se mostrará en la **pantalla (5)** con la barra de estado y la flecha ▲ (hacia arriba) y se mostrará el valor real de la temperatura de soldadura (intermitente) (fig. 5).
Cuando se alcanza el valor nominal de la temperatura de soldadura, las flechas y las barras de estado dejarán de mostrarse (fig. 6).

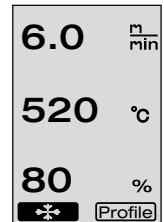

(Fig. 5)



(Fig. 6)

- Si la tensión de red se encuentra fuera (+/- 15%) de la tensión nominal predeterminada, se mostrará de forma alterna el símbolo con la sobretensión  o infratensión  correspondiente y la cantidad de aire ajustada. Si la cantidad de aire es 100%, se mostrará el símbolo intermitente con la sobre  / infratensión  medida (fig. 7).
(Solo posible en VARIANT T1 230 V~).

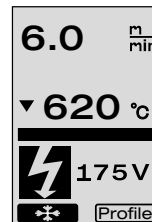

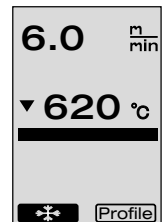

(Fig. 7)



(Fig. 8)













¡La sobre/infratensión puede afectar al resultado de la soldadura!

- Si, tras un plazo definido, no se pulsa ninguna tecla y la **boquilla de soldadura (9)** NO se encuentra en la posición de soldadura, se mostrará el menú de Standby (capítulo 1.9, Standby).
- Si la **boquilla de soldadura (9)** se encuentra en la posición de parada, se podrán seleccionar los menús Cool Down (capítulo 1.8, Enfriamiento) o Profile (capítulo 1.7, Selección de perfil) girando el e-Drive .
- Si la **boquilla de soldadura (9)** está introducida, desaparecerán los dos puntos de menú  de la **pantalla (5)** y no se podrán seleccionar.
- Mientras se enfría la **boquilla de soldadura (9)**, el proceso se representará con la barra de estado y la flecha ▼ (hacia abajo) y con el valor real de la temperatura de soldadura intermitente en la **pantalla (5)** (fig. 8).

1. Modo de trabajo





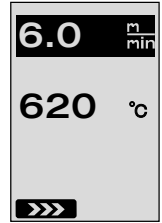

1.3 Ajuste de la velocidad de accionamiento

- Con la tecla de accionamiento  se puede adaptar la velocidad de accionamiento. Se puede ajustar girando el e-Drive  en pasos de 0,1 m/min desde 1,5 m/min hasta 18,0 m/min. Este ajuste se puede realizar con el accionamiento conectado o desconectado. Si no se introduce ningún dato durante 3 segundos con los **elementos de manejo (4)**, se aplicará la nueva velocidad de accionamiento. En la **pantalla (5)** aparecerán los indicadores de valores nominales de trabajo o Cool Down (fig. 9).
- Si la **boquilla de soldadura (9)** no se encuentra en la posición de soldadura, aparece en el borde inferior izquierdo de la **pantalla (5)** el símbolo (inicio)  .
- Pulsando el e-Drive  se puede conectar el accionamiento y aparece el símbolo (parada)  . La velocidad de accionamiento se puede ajustar directamente girando el e-Drive  .
- Volviendo a pulsar el e-Drive  se ejecutará la orden de parada y se desconectará el accionamiento. En la pantalla aparecerán los indicadores de valores nominales de trabajo o Cool Down.
- Si se pulsa la tecla de accionamiento  durante 3 segundos, el indicador cambia a otro menú (véase el capítulo 1.6 Medición de extensión, contador de accionamiento y contador de soplador).
- Con la tecla de calefacción  o la tecla del soplante  se puede cambiar al menú correspondiente.



(Fig. 9)

1.4 Ajuste de la temperatura de soldadura

- Con la tecla de calefacción  se puede modificar la temperatura de soldadura. La temperatura de soldadura se puede ajustar en pasos de 10 °C desde 100 °C hasta 620 °C girando el e-Drive  . El ajuste se aplicará tras 3 segundos, si no se pulsa ninguna tecla durante estos 3 segundos (fig. 10).
- Si se accede a este menú desde el indicador de valores nominales, podrá iniciar la calefacción y el soplante pulsando el e-Drive  . Si la calefacción está conectada, se puede seleccionar el menú Cool Down (capítulo 1.8, Enfriamiento) (fig. 11).
- Al pulsar la tecla de calefacción  durante 3 segundos, aparece la tensión de red debajo de la velocidad de accionamiento. Esta consulta sólo es posible en los indicadores de trabajo (capítulo 1.2). (Solo posible en VARIANT T1 230 V~).
- Con la tecla de accionamiento  o la tecla del soplante  se puede cambiar al menú correspondiente.

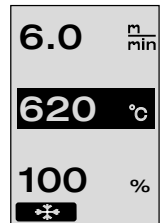



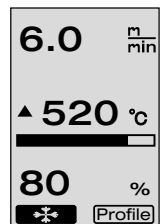



(Fig. 10)



(Fig. 11)

1. Modo de trabajo



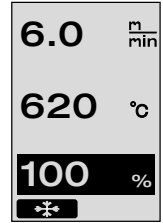

1.5 Ajuste de la cantidad de aire

- Con la tecla de soplante  se puede modificar la cantidad de aire. La cantidad de aire se puede ajustar en pasos de 5% desde 40% hasta 100% girando el e-Drive . El ajuste se aplicará tras 3 segundos, si no se pulsa ninguna tecla durante estos 3 segundos. Si la cantidad de aire está ajustada en 100%, no aparecerá ningún indicador en la **pantalla (5)** (fig. 12).
- Si se accede a este menú desde el indicador de valores nominales, podrá iniciar la calefacción y el soplante pulsando el e-Drive .
- El menú Cool Down se puede seleccionar pulsando el e-Drive  (capítulo 1.8, Enfriamiento).
- Con la tecla de accionamiento  o la tecla de calefacción  se puede cambiar al menú correspondiente.



(Fig. 12)

1.6 Medición de extensión, contador de accionamiento y contador de soplador

- Este menú (fig. 13) aparece cuando se pulsa la tecla de accionamiento  durante al menos 3 segundos.
- El menú muestra todas las horas de funcionamiento y la distancia que ha recorrido el equipo desde su conexión. La distancia total (aquí: 1034 m) no se puede cambiar y muestra todo el recorrido desde la puesta en marcha.
- La distancia diaria (aquí: 012 m) no se restablece automáticamente, sino que la debe poner a cero el usuario con **Reset** pulsando el e-Drive .
- Los valores Time indican las horas de funcionamiento de cada componente individual del equipo. Se indican el tiempo del soplante «Blow» (aquí: 043:58) y del accionamiento «Drive» (aquí: 020:10). El tiempo «Total» hace referencia al tiempo de funcionamiento. Cuenta las horas y los minutos (aquí: 143:12) que ha estado encendido el **interruptor principal (3)**.
- Si se selecciona pulsando el e-Drive  la flecha Back , se vuelve al menú desde el que se ha pulsado la tecla de accionamiento .

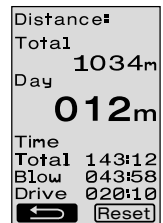

(Fig. 13)

1. Modo de trabajo

1.7 Selección de perfil

- Si está activado el indicador **Profile** en la parte inferior derecha de la **pantalla (5)**, se pueden cargar perfiles pulsando el e-Drive . A continuación, aparece el indicador «Select Profile». Al girar el e-Drive  se puede seleccionar un perfil. Los perfiles FREE 1–7 los puede definir el usuario por sí mismo (ver capítulo 2 Configuración de perfiles). Todos los demás perfiles tienen valores fijos y no los puede definir el usuario (fig. 14).
- Girando el e-Drive  se pueden activar en la pantalla (5) las flechas de abajo a la izquierda o a la derecha.
Flecha a la derecha  pulsando el e-Drive  a la siguiente página (fig. 15).
Flecha a la izquierda  pulsando el e-Drive  a la página anterior (fig. 16)
- Si se activa la flecha Back  girando el e-Drive , se vuelve pulsando el e-Drive  al menú desde donde se accedió al menú de perfil (Fig. 15).

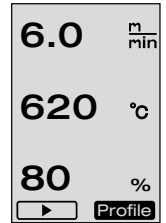

(Fig. 14)

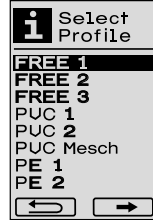

(Fig. 15)

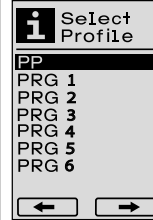

(Fig. 16)

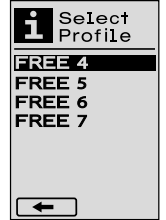

Realizar una soldadura de prueba conforme a las instrucciones de soldadura del fabricante del material o las normas y directivas nacionales. Comprobar la soldadura de prueba.

1.8 Enfriamiento

- Si se selecciona el símbolo  pulsando el e-Drive  (fig. 17), aparece el menú «Cool down OK?» (Fig. 18). Al pulsar el e-Drive  se activa el símbolo OK abajo a la derecha en la **pantalla (5)**. De esta forma, se inicia el enfriamiento.
- Durante el proceso de enfriamiento, se aumenta la cantidad de aire al 100% y se muestra la temperatura de soldadura de ese momento (fig. 19). Si la temperatura cae por debajo de 60 °C, el soplante funciona dos minutos más y se apaga automáticamente después. El indicador cambia al indicador de valor nominal.
- Al pulsar el e-Drive  durante el proceso de enfriamiento, se inicia la calefacción y aparece en la **pantalla (5)** el indicador de trabajo (ver el capítulo 1.2 Indicadores de trabajo).
- Si el menú Cool Down está activo, se puede conectar y desconectar manualmente el accionamiento con la tecla de accionamiento . La tecla de calefacción  y del soplante  no tienen ninguna función.

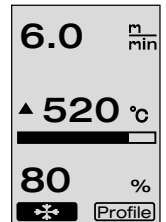

(Fig. 17)



(Fig. 18)

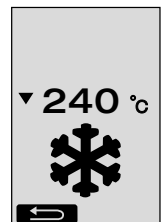

(Fig. 19)

1. Modo de trabajo

1.9 Standby

- Si la **boquilla de soldadura (9)** no se encuentra en la posición de soldadura y no se pulsa ninguna tecla durante el tiempo de standby definido por el usuario, se inicia automáticamente el modo Cool Down cuando trascorra la cuenta atrás (fig. 20). Se iniciará el proceso de enfriamiento.
- Si se pulsa el e-Drive antes de que trascorra la cuenta atrás (180 segundos) , la **pantalla (5)** cambiará al indicador de trabajo (ver capítulo 1.2 Indicadores de trabajo).
- Ajuste del tiempo de standby (capítulo 2.3, Configuración de standby).

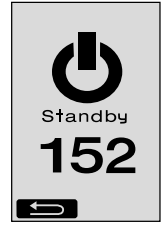

(Fig. 20)

1.10 Mensajes de error

- Si se produce un fallo de funcionamiento en la soldadura automática de aire caliente VARIANT T1, aparece un mensaje en la **pantalla (5)** con un código de error adicional. Este código es una indicación precisa del fallo y se indica en la siguiente lista.
- En los fallos 02 y 40, se mostrarán símbolos diferentes.
- En todos los demás fallos, se muestra la llave inglesa que indica que debe recurrirse al servicio técnico.



Error	Tipo de fallo
Err00	Sistema electrónico de control defectuoso
Err01	Interrupción o cortocircuito en la sonda de temperatura
Err02	Avería en el elemento calentador/sistema electrónico (interrupción en una/ambas bobina/s)
Err04	Avería de Triac (uno o ambos Triacs están averiados)
Err08	Avería en el motor del soplante
Err40	Tensión insuficiente 25% (tensión de red 75%), sólo VARIANT T1 230V~

2. Configuración de perfiles





2.1 Combinación de teclas para configuración de perfiles

Mantener pulsadas las teclas de accionamiento y calefacción y activar al mismo tiempo el interruptor principal





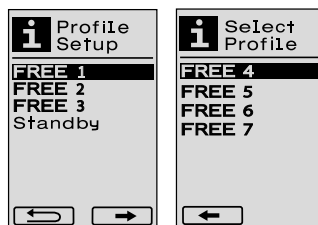

2. Configuración de perfiles

2.2 Creación de un perfil

- En la configuración de perfiles, se pueden crear 7 perfiles individuales en los que se pueden ajustar libremente el nombre y los tres parámetros de accionamiento , calefacción , soplante , y, a continuación, se pueden guardar pulsando el e-Drive  (fig.21).
- Los diferentes puntos de menú se pueden seleccionar mediante de los **elementos de manejo (4)**. Pulsando el e-Drive  se vuelve a la selección de configuración de perfiles.







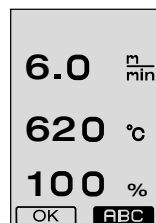

(Fig. 21)

- Girando el e-Drive  se pueden activar en la pantalla (5) las flechas de abajo a la izquierda o a la derecha.
Flecha a la derecha  pulsando el e-Drive  a la siguiente página (fig. 15).
Flecha a la izquierda  pulsando el e-Drive  a la página anterior (fig. 16)













(Fig. 22)

- Si se activa el símbolo  ABC girando el e-Drive , se accede al menú Profile Name girando el e-Drive  (fig. 22).
- En el menú Profile Name, girando el e-Drive , se pueden seleccionar los caracteres _ / . / A a Z / 0 a 9, así como las flechas izquierda o derecha y los símbolos Save  o Back .





(Fig. 23)

- Modificar nombre de perfil
 - Girando el e-Drive  se pueden seleccionar las flechas a la izquierda o a la derecha. Si se activa la flecha derecha pulsando el e-Drive , la posición del nombre de perfil, salta un puesto (negro) hacia la derecha. Si se activa la flecha a la izquierda pulsando el e-Drive , la posición del nombre de perfil, salta un puesto (negro) hacia la izquierda (fig. 23).
 - Girando el e-Drive  se puede seleccionar el carácter deseado (_ / . / A a Z / 0 a 9). Presionando el e-Drive  se sustituirán los caracteres representados en negro en el nombre del perfil por los caracteres seleccionados previamente.
- Guardar o descartar el nombre de perfil
 - Si se selecciona el símbolo Save  girando el e-Drive , se guardará el nombre de perfil pulsando el e-Drive .
 - Si se selecciona el símbolo Back  girando el e-Drive , se descartará (no se guardará) el nombre de perfil pulsando el e-Drive .



Realizar una soldadura de prueba conforme a las instrucciones de soldadura del fabricante del material y las normas o directivas nacionales. Comprobar la soldadura de prueba.

2.3 Configuración de Standby

- El tiempo de standby indica el tiempo que debe transcurrir (sin que se pulse ninguna tecla, la **boquilla de soldadura (9)** no puede estar en la posición de soldadura) para que se active el proceso de enfriamiento (ver capítulo 1.8 Enfriamiento).
- Girando el e-Drive  se puede ajustar el tiempo entre 5 y 120 minutos. El ajuste de fábrica es de 40 minutos.
- Pulsando el e-Drive  volverá a la selección de elementos de configuración de perfiles.

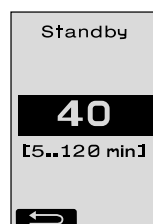

- La máquina se desconecta automáticamente
 - Con el modo Standby, la máquina se desconectará automáticamente cuando transcurra el tiempo ajustado (el ajuste de fábrica es de 40 minutos). En caso necesario, aumentar el tiempo de standby (página 87, 2. Configuración de perfiles, 2.3 Configuración de standby).
- Mala calidad de la soldadura
 - Comprobar la velocidad de accionamiento, la temperatura de soldadura y la cantidad de aire
 - Limpiar la **boquilla de soldadura (9)** con un cepillo de latón
 - La **boquilla de soldadura (9)** está mal ajustada

Realizar el ajuste de la boquilla de soldadura (9) de la siguiente forma

- A** Enfriar la **boquilla de soldadura (9)** (página 85, 1. Modo de trabajo, 1.8 Enfriamiento)
- B** Aflojar los tornillos Allen del soporte del equipo
- C** Realizar el ajuste angular girando el **soplante de aire caliente (8)**.
- D** La **boquilla de soldadura (9)** (flecha L) debe estar sobre el **calibrador de boquillas (34)** y (flecha R) el suelo.
- E** Apretar los tornillos Allen del soporte del equipo
- F** Colocar el **calibrador de boquillas (34)** en su posición. Tenga en cuenta la escala del **calibrador de boquillas (34)**
- G** Colocar el **soplante de aire caliente (8)** en la posición de soldadura
- H** Aflojar los **tornillos de ajuste del eje pivotante (25)**
- I** Poner el **soplante de aire caliente (8)** en paralelo al **calibrador de boquillas (34)**
- J** Apretar los **tornillos de ajuste del eje pivotante (25)**
- K** Retirar el **calibrador de boquillas (34)** y realizar una soldadura de prueba.

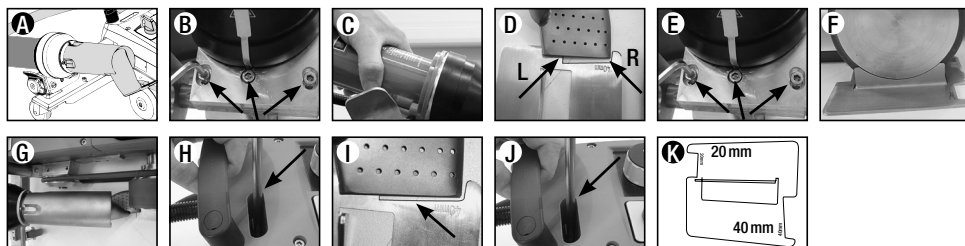

- No se alcanza la temperatura ajustada (parpadea el indicador de temperatura)
 - Controlar la tensión de red
 - Reducir la cantidad de aire
 - Reducir la temperatura
- El soplante de aire caliente no se encaja en la posición de soldadura
 - Se debe ajustar de la siguiente forma la pieza esférica de retención:
 - Enfriar la **boquilla de soldadura (9)** (página 85, 1. Modo de trabajo, 1.8 Enfriamiento)
 - Colocar la **boquilla de soldadura (9)** en la posición de soldadura
 - Apretar ligeramente el **tornillo (30)** con un destornillador, después girar el **tornillo (30)** aprox. media vuelta.

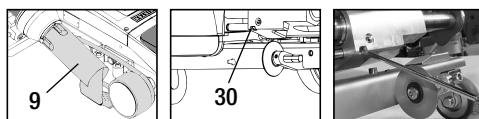

- El ancho de la costura de soldadura no es constante
 - Realizar el ajuste del rodillo guía de la siguiente forma:
 - Enfriar la **boquilla de soldadura (9)** (página 85, 1. Modo de trabajo, 1.8 Enfriamiento)
 - Colocar la **boquilla de soldadura (9)** en la posición de soldadura
 - Aflojar el tornillo Allen del **rodillo guía (15)**
 - Desplazar el **rodillo guía (15)** a la posición deseada
 - Apretar el tornillo Allen
 - Realizar una soldadura de prueba

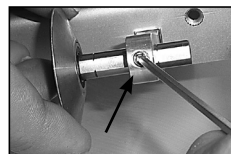
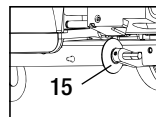
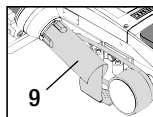

- La soldadora automática de aire caliente se separa de la costura (soldadura a solape)
 - Ajuste preciso del trazado del **rodillo de dirección (14)** de la siguiente forma:
 - Enfriar la **boquilla de soldadura (9)** (página 85, 1. Modo de trabajo, 1.8 Enfriamiento)
 - Apagar el **Interruptor principal (3)**
 - Desconectar el cable de conexión de red de la red eléctrica
 - Retirar el **peso adicional (16)**
 - Tumbarse lateralmente la soldadora automática
 - Aflojar el **tornillo de tope para ajuste preciso de trazado (31)** y desplazar a la posición deseada la **palanca para ajuste preciso de trazado (32)**
 - Apretar el **tornillo de tope de ajuste preciso de trazado (31)**
 - Colocar la soldadora automática de aire caliente en la posición de soldadura
 - Colocar el **peso adicional (16)**
 - Volver a poner en funcionamiento la soldadora automática
 - Realizar una soldadura de prueba

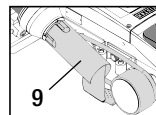
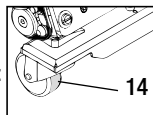



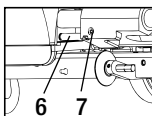
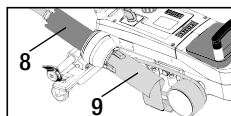
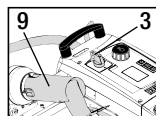

- El dispositivo de arranque automático no funciona

Si el motor de accionamiento no se inicia automáticamente tras encajar la **boquilla de soldadura (9)**, el **sensor de arranque (6)** puede estar mal ajustado.

 - Ajustar el **sensor de arranque (6)** de la siguiente forma:
 - Enfriar la **boquilla de soldadura (9)** (página 85, 1. Modo de trabajo, 1.8 Enfriamiento)
 - Apagar el **Interruptor principal (3)**
 - Con el **soplante de aire caliente (8)**, girar y encajar la **boquilla de soldadura (9)** en la posición de soldadura.
 - Realizar el ajuste del **sensor de arranque (6)** en el **tornillo de sujeción (7)** con una llave Allen; **IMPORTANTE: Distancia de detección 0,2 – 0,5 mm**
 - Comprobar el funcionamiento



Si el motor de accionamiento aún no se inicia automáticamente, deberá ponerse en contacto con el punto de servicio.

	Solape	Reborde	Jareta (hasta 70mm)	Cordón de burlete	Burlete prefabricado
	●	●	●		
		●	●	●	
		●		●	●
				●	●

Aplicación

En lugar del rodillo guía (15), se puede trabajar también con una pieza de ampliación para rebordes y burletes.

También posible con modelo estándar y fijación de lonas.

También posible con modelo estándar y fijación de lonas.

Se recomienda una superficie con ranura longitudinal para los burletes.

Fijación sin pliegues de burletes prefabricados.

Tipo

Buena fijación de la lona.

Marcado de solapes de rebordes para un mejor control de la guía.

Marcado de solapes de rebordes para un mejor control de la guía.

Marcado de los solapes de rebordes para un mejor control de la guía. Dejar que el equipo avance solo, guía manual de las lonas con burlete

Modelos de Leister VARIANT T1

Referencia 141.891 VARIANT T1, 230 V / 40 mm boquilla de soldadura / con europlug

Referencia 141.892 VARIANT T1, 230 V / 20 mm boquilla de soldadura / con europlug

Referencia 141.893 VARIANT T1, 400 V / 40 mm boquilla de soldadura / con enchufe CEE (3LNPE)

Referencia 141.894 VARIANT T1, 400 V / 20 mm boquilla de soldadura / con enchufe CEE (3LNPE)

Referencia 147.739 VARIANT T1, 200 V / 40 mm boquilla de soldadura / sin enchufe

Referencia 147.748 VARIANT T1, 200 V / 20 mm boquilla de soldadura / sin enchufe

Accesorios

Por motivos técnicos e importantes para la seguridad, deben utilizarse exclusivamente accesorios de Leister.

Referencia 142.650 kit de rebordes y burletes completo

Referencia 139.438 Peso adicional

Referencia 140.530 Pieza de ampliación para rebordes y burletes

Referencia 137.843 Pieza superior para palo guía con agarre en T

Referencia 142.221 Pulsador

Referencia 116.798 Cepillo de latón

Referencia 141.326 Guía de burlete

Referencia 142.705 Maletín de transporte

Formación

- Leister Technologies AG y sus sucursales de servicio autorizadas ofrecen de forma gratuita cursos y formación sobre soldadura. Encontrará información en www.leister.com.

Mantenimiento

- La entrada de aire en el **soplante de aire caliente (8)** se deberá limpiar con un pincel si está sucia.
- Limpiar la **boquilla de soldadura (9)** con un cepillo de latón
- Controlar que el **cable de conexión de red (1)** y el enchufe no tengan daños mecánicos ni eléctricos.



Servicio y reparaciones

- Si el contador de horas de servicio alcanza las 400 h o el contador del soplador las 2000 h, aparecerá en la **pantalla (5)**, la próxima vez que encienda el **interruptor principal (3)**, el mensaje «Maintenance servicing». El mensaje se mostrará durante 10 segundos y no se puede ocultar con los **elementos de manejo (4)**.
- Las reparaciones se realizarán únicamente en oficinas de servicio técnico autorizadas por Leister. Estas garantizan un **servicio de reparación** fiable y especializado **durante 24 horas** con piezas de repuesto originales conforme a los planos de conexiones y las listas de piezas de repuesto.

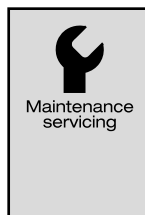

Garantía

- Para este dispositivo tienen validez los derechos de garantía comercial o legal concedidos por el socio de distribución directo/el vendedor a partir de la fecha de compra. En caso de que exista derecho de garantía comercial o legal (certificación mediante factura o albarán de entrega), el socio de distribución subsanará los daños de fabricación o tratamiento con una entrega de reposición o una reparación. Las resistencias están excluidas de la garantía.
- Cualquier otro derecho de garantía comercial o legal se excluirá en el marco del derecho imperativo.
- Los daños provocados por el desgaste natural del equipo, sobrecarga o manejos inadecuados quedan excluidos de la garantía.
- No habrá ningún derecho de garantía comercial o legal en el caso de los dispositivos que hayan sido alterados o modificados por el comprador.

Parabéns pela compra de uma Máquina de soldadura a ar quente VARIANT T1

Escolheu uma máquina de soldadura a ar quente excelente, que consiste de materiais de elevada qualidade. Este aparelho foi desenvolvido e produzido de acordo com as tecnologias de soldadura mais recentes. Cada VARIANT T1 é submetida a um controlo de qualidade antes de sair da fábrica na Suíça.

Índice

Aplicação, Aviso, Cuidado	Página	93
Conformidade, Eliminação, Dados técnicos	Página	94
Descrição do aparelho, Elementos de comando	Página	95
Ícones de informação, Ícones activos, Informações rápidas	Página	96
Operacionalidade, Posicionamento do aparelho	Página	97
Processo de soldadura	Página	98
Operacionalidade de transporte, Combinação dos botões	Página	99
Modo de trabalho (Capítulo 1)		
1.1 Indicação do valor nominal		
1.2 Indicação do trabalho	Página	100
1.3 Ajuste da velocidade do actuador		
1.4 Ajuste da temperatura de soldadura	Página	101
1.5 Ajuste da quantidade de ar		
1.6 Medição longitudinal, Contador de ventilador e de actuador	Página	102
1.7 Seleccionar perfis		
1.8 Arrefecimento	Página	103
1.9 Standby		
1.10 Mensagens de erro		
Setup de perfis (Capítulo 2)		
2.1 Setup de perfis Combinação dos botões	Página	104
2.2 Criar perfis		
2.3 Standby Setup	Página	105
FAQ (Perguntas frequentes)	Página	106/107
Aplicações de soldadura	Página	108
Versões, Acessórios, Formação, Manutenção, Assistência e reparação, Garantia	Página	109



Ler atentamente o manual de instruções antes da colocação em funcionamento e guardar para disponibilização.

Leister VARIANT T1 Máquina de soldadura a ar quente

Aplicação

O aparelho somente deve ser usado em espaços bem ventilados. Se necessário, deve trabalhar-se com um dispositivo de aspiração ou com equipamento de proteção pessoal. Tenha atenção para o material não queimar durante o processo de soldagem. Verifique os aditivos prejudiciais à saúde com o fabricante do material. Devem ser aplicados os regulamentos legais relativos à proteção sanitária do país.

- Máquina de soldadura a ar quente conduzida manualmente para costuras de soldadura por sobreposição, bainha e Keder de material de toldes (PVC e materiais semelhantes).
- Preparação apenas em espaços bem ventilados



Aviso



Perigo de vida ao abrir o aparelho visto que os componentes sob tensão e ligações estão livres. Antes de abrir o aparelho retirar a ficha da tomada.



Perigo de incêndio e explosão em caso de uma utilização incorrecta de aparelhos a ar quente, especialmente na proximidade de materiais inflamáveis e gases explosivos.



Perigo de queimaduras! Não tocar no bocal de soldadura quando o mesmo está quente. Deixar arrefecer o aparelho.
Não direccionar o jacto de ar quente para pessoas e animais.



Ligar o aparelho a **uma tomada com condutor de protecção**. Cada interrupção do condutor de protecção dentro ou fora do aparelho é perigosa!
Utilizar apenas extensões com condutor de protecção!



Cuidado



A **tensão nominal** mencionada no aparelho tem de corresponder à tensão de rede. EN 61000-3-11; $Z_{max} = 0.164 \Omega + j 0.102 \Omega$. Caso necessário, consultar empresa de abastecimento de electricidade.
Em caso de **falha de rede** extrair o ventilador de ar quente.



Interruptor FI na utilização do aparelho em obras é necessário para a protecção pessoal.



O aparelho tem de ser operado **sob vigilância**. O calor pode alcançar materiais inflamáveis que se encontram fora do campo de visão.



O aparelho apenas pode ser utilizado por **pessoal especializado qualificado** ou sob vigilância. A utilização por crianças é completamente proibida.

Proteger o aparelho **de humidade e água**.



O aparelho não pode ser elevado no peso adicional.

Conformidade

Leister Technologies AG, Galileo-Strasse 10, CH-6056 Kaegiswil/Suíça confirma, que este produto, colocado por nós no mercado na seguinte versão, cumpre os requisitos das seguintes directivas da UE.

Directivas: 2006/42/EC, 2014/30/EU, 2011/65/EU

Normas harmonizadas: EN ISO 12100, EN 55014-1, EN 55014-2, EN 61000-3-2, EN 61000-3-3, EN 61000-3-11 (Z_{max}), EN 61000-6-2, EN 62233, EN 60335-1, EN 60335-2-45, EN IEC 63000

Kaegiswil, 05.11.2020

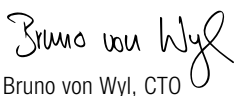
Bruno von Wyl, CTO

Christoph Baumgartner, GM

Eliminação



Equipamentos elétricos, acessórios e embalagens devem ser conduzidos para uma reciclagem compatível com o ambiente. Não jogue equipamentos elétricos no lixo doméstico!

Dados técnicos

Tensão	V~	200	230	400 (2LNPE)	V~	200	230	400 (2LNPE)
Potência	W	4200, 3680, 5700			W	4200, 3680, 5700		
Frequência	Hz	50/60			Hz	50/60		
Temperatura	°C	100 – 620 sem níveis			°F	212 – 1148 sem níveis		
Actuador	m/min.	1.5 – 18 sem níveis			ft/min	4.9 – 59.1 sem níveis		
Quantidade de ar	%	40 – 100			%	40 – 100		
Nível de emissão	L _{pA} (dB)	70			L _{pA} (dB)	70		
Peso	kg	22			lbs	48.5		
sem cabo de alimentação								
Dimensões C × L × A	mm	500 × 400 × 195			inch	19.7 × 15.8 × 7.7		
Símbolo de conformidade		CE				CE		
Classe de protecção I								

Não é possível comutar a tensão de ligação

Reservam-se os direitos a alterações técnicas.

Descrição do aparelho

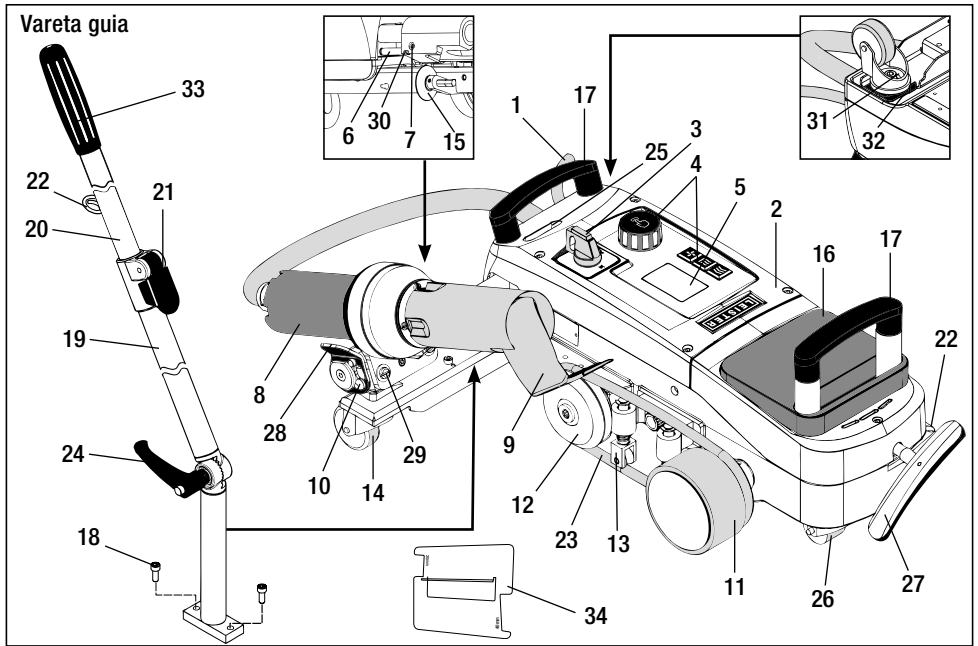

- | | | |
|---|-------------------------------------|--|
| 1 Cabo de alimentação | 12 Rolo de desvio | 24 Alavanca de rosca |
| 2 Caixa | 13 Placa de sustentação | Parte inferior da vareta guia |
| 3 Interruptor principal | 14 Rolo de oscilantes | 25 Parafusos de ajuste eixo oscilante |
| 4 Elementos de comando | 15 Rolo guia | 26 Rolo de transporte |
| 5 Visor | 16 Peso adicional | 27 Pega para equipamento de elevação |
| 6 Sensor de arranque | 17 Pega de transporte | 28 Dispositivo de fixação |
| 7 Perno roscado para ajuste do sensor de arranque | 18 Parafuso cilíndrico | 29 Ajuste de ângulo suporte do aparelho |
| 8 Ventilador de ar quente | 19 Parte inferior da vareta guia | 30 Parafuso de bloqueio para posição de soldadura |
| 9 Bocal de soldadura | 20 Parte superior da vareta guia | 31 Parafuso de bloqueio para ajuste preciso da faixa |
| 10 Came de bloqueio para ventilador de ar quente | 21 Alavanca de aperto | 32 Alavanca para ajuste preciso da faixa |
| 11 Rolo de pressão | 22 Suporte para cabo de alimentação | 33 Pega vareta guia |
| | 23 Correias roliças | 34 Calibre do bocal |

Interruptor principal (3)



Para ligar / desligar da máquina de soldadura a ar quente VARIANT T1

Elementos de comando (4)



e-Drive

O e-Drive serve como navegador.

Este possui duas funções:



Rodar para a esquerda ou para a direita para ajustar diversos menus ou valores



Premir para confirmar ou activar



Actuador

Ajustar a velocidade do actuador



Aquecimento

Ajuste da temperatura de soldadura



Ventilador

Ajustar a quantidade de ar

Ícones de informação

Os seguintes ícones são apresentados para informação no visor.



Bocal de soldadura
arrefece



Aparelho no modo
Standby, aparelho desli-
ga-se depois de terminar



Contactar ponto de assistência
autorizada



Indica que a temperatura está a subir



Indica que a temperatura está a descer



Barra indicadora de progresso

Ícones activos

Os seguintes ícones são apresentados no visor e activados, premindo o e-Drive .



Ligação do aquecimento e ventilador
(caso o ventilador ainda não trabalhe)



Paragem do actuador



Início do actuador



Arrefecimento automático
(aquecimento desligado, ventilador ligado)



Na estrutura para cima
(regressar para o programa anterior)



Enter, Confirmar



Seleccionar perfis



Memorizar nome alterado



Alterar nome do perfil



Para a próxima página



Para a próxima página



Repor a distância diária para zero





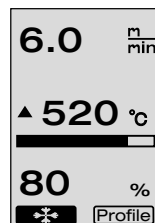
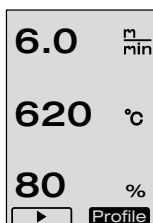







Ícones de informação

Ícones activos



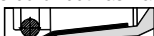

Informação rápida

Como ligo a máquina de soldadura a ar quente VARIANT T1 ?

- Ligar o cabo de alimentação à rede eléctrica 
- Interruptor principal (3) LIGADO 
- Premir botão Actuador  →  rodar e-Drive 
- Premir botão Aquecimento  →  rodar e-Drive 
- Premir botão Ventilador  →  rodar e-Drive 
- Premir e-Drive  Tempo de aquecimento aprox. 1 – 2 minutos → 
- Proceder à soldagem de teste de acordo com o fabricante do material e as normas ou directivas nacionais. Verificar soldagem de teste.
- Soldagem 

Como desligo a máquina de soldadura a ar quente VARIANT T1 ?

- Premir e-Drive  (fig. 1).
- «Cool down OK» premir e-Drive  e arrefecer aprox. 4 minutos (fig 2). O ventilador desliga-se automaticamente.
- Após o arrefecimento do bocal de soldadura (9) interruptor principal (3) DESLIGADO 

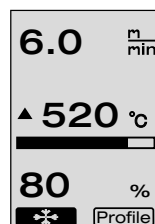

(fig. 1)

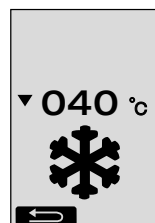

(fig. 2)

Operacionalidade

- Antes da colocação em funcionamento verificar o **cabo de alimentação (1)** e a ficha, bem como, a extensão quanto a danos eléctricos e mecânicos.
- A configuração base do **bocal de soldadura (9)** é efectuada na fábrica
- Controlar a configuração base do **bocal de soldadura (9)**
 - O controlo pode ser efectuada através do **calibre do bocal (34)** ou de acordo com detalhe A e B.

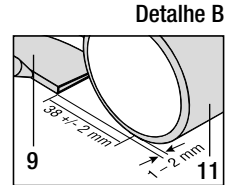
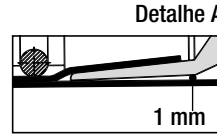
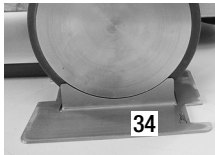

- Montar **vareta de guia** com **parafusos cilíndricos (18)**.
 - Colocar a **parte inferior da vareta guia (19)** através da **alavanca de rosca (24)** e a **parte superior da vareta guia (20)** através da **alavanca de aperto (21)** para a posição desejada.
 - Pendurar a pinça de fixação do **cabo de alimentação (1)** no **suporte (22)** na vareta guia ou na armação.

- Colocar **peso adicional (16)** (no máx. dois pesos adicionais)

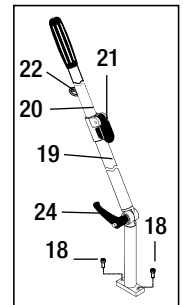
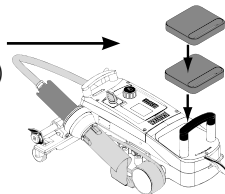

Ligar o aparelho à tensão de rede. A tensão nominal mencionada no aparelho tem de corresponder à tensão de rede.

Em caso de **falha de rede** extrair o **ventilador de ar quente (8)** para a posição de estacionamento.

Posicionamento do aparelho

- O material do tolde tem de estar limpo entre a sobreposição, bem como no lado superior e inferior.
- O **bocal de soldadura (9)**, **rolo de pressão (11)**, **rolo de desvio (12)** e **correia roliça (23)**, bem como **placa de sustentação (13)** têm de estar limpos.
- Se a máquina de soldadura a ar quente não se encontrar em operacionalidade de transporte, elevar o aparelho através da **pega (27)** do equipamento de elevação. Os **rolos de transporte (26)** encontram-se agora funcionais.
- Deslocar a máquina de soldadura a ar quente para a posição de soldadura.
- Com a **pega (27)** baixar a máquina de soldadura a ar quente para a posição de soldadura. Os **rolos de transporte (26)** não possuem mais qualquer função e estão, assim, aliviados.
- Rodar **rolo guia (15)** para baixo
- O **rolo guia (15)** tem de encontrar-se paralelo em relação ao **rolo de pressão (11)** (Detalhe C).

Operacionalidade de transporte
Pega esquerda

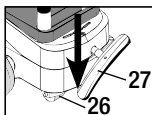

Posição de soldadura
Pega direita

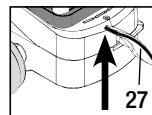

Detalhe C

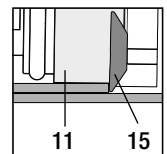

Processo de soldadura

• Preparação



Proceder à soldagem de teste de acordo com o fabricante do material e as normas ou directivas nacionais. Verificar soldagem de teste.

- Ajustar actuador de parâmetros de soldadura, aquecimento e ventilador (capítulo 1, modo de trabalho)
- Temperatura de soldadura tem de estar alcançada (tempo de aquecimento aprox. 1–2 min.)

• Iniciar soldagem





- Rodar **rolo guia (15)** para baixo
- Abrir e fechar ligeiramente o **ventilador de ar quente (8)**, até que o **came de bloqueio (10)** se encontra deslocado para fora do entalhe. Baixar imediatamente o **ventilador de ar quente (8)**.



ATENÇÃO: Se o **ventilador de ar quente (8)** for recolhido e rebaixado de mais o **bocal de soldadura (9)** e o **rolo de pressão (11)** entram em contacto. Assim o **ventilador de ar quente (8)** não pode ser baixado.

- Levantar ligeiramente o material superior do tolde do rolo guia e deslocando o **ventilador de ar quente (8)** recolher o **bocal de soldadura (9)** entre os toldes sobrepostos.





- O motor do actuador arranca automaticamente. Nenhum arranque automático (capítulo FAQ (perguntas frequentes, página 107)
- A máquina pode ser iniciada manualmente com os **elementos de comando (4)** actuador  e e-Drive 
- Se o actuador for iniciado através de  e e-Drive  e de seguida inserido o **bocal de soldadura (9)**, a máquina de soldadura a ar quente continua após oscilação do **bocal de soldadura (9)** por aprox. 30 cm (desconexão retardada do actuador).
- A máquina de soldadura a ar quente pode ser conduzida ao longo da sobreposição através da **pega da vareta guia (33)**, **pega de transporte (7)** ou **pega de fixação (28)**. Durante a soldadura, conduza a máquina de soldadura a ar quente sem exercer pressão na **pega da vareta de guia (33)**, **pega de transporte (17)** ou **pega de fixação (28)**. Pressão pode conduzir a erros de soldadura. Considerar posição do **rolo guia (15)**.

• Fim da soldagem

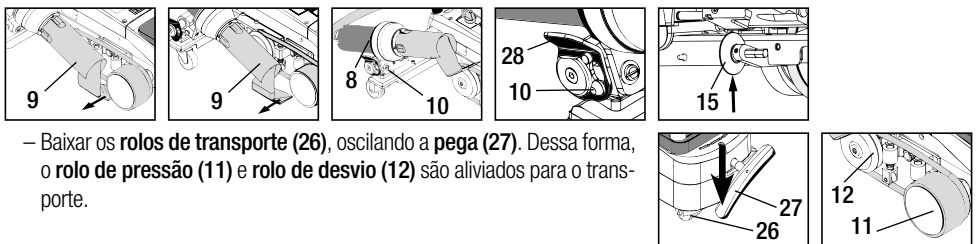
- Após a soldagem deslocar e elevar o **bocal de soldadura (9)** através do **ventilador de ar quente (8)** da posição de soldadura para a direita.
- Deslocar **ventilador de ar quente (8)** para a direita até que o **came de bloqueio (10)** encaixe no entalhe da **pega de fixação (28)**. Ventilador de ar quente (8) encontra-se na posição de estacionamento.
- Rodar o **rolo guia (15)** para cima



- Baixar os **rolos de transporte (26)**, oscilando a **pega (27)**. Dessa forma, o **rolo de pressão (11)** e **rolo de desvio (12)** são aliviados para o transporte.

- Após terminar os trabalhos de soldadura desligar o aquecimento através do e-Drive   (premir 2 x), assim o **bocal de soldadura (9)** arrefece e o ventilador desliga automaticamente após 4 minutos (capítulo 1.8, Arrefecer).
- Desligar **interruptor principal (3)** OFF 



Separar cabo de alimentação da rede eléctrica.

- Limpar o **bocal de soldadura (9)** com escova em latão

Operacionalidade de transporte

- Rodar o **rolo guia (15)** para cima.
- Deslocar **ventilador de ar quente (8)** para a direita até que o **came de bloqueio (10)** encaixe no entalhe da **pega de fixação (28)**. Ventilador de ar quente (8) encontra-se na posição de estacionamento.
- Baixar os **rolos de transporte (26)**, oscilando a **pega (27)**. Dessa forma, o **rolo de pressão (11)** e rolo de desvio (12) são aliviados para o transporte.

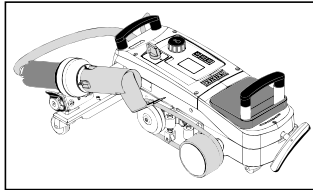
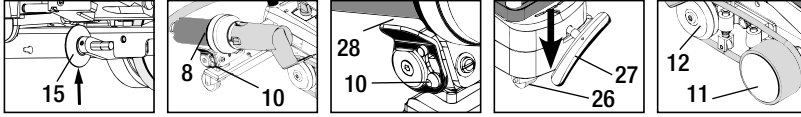

Deslocar



Transportar

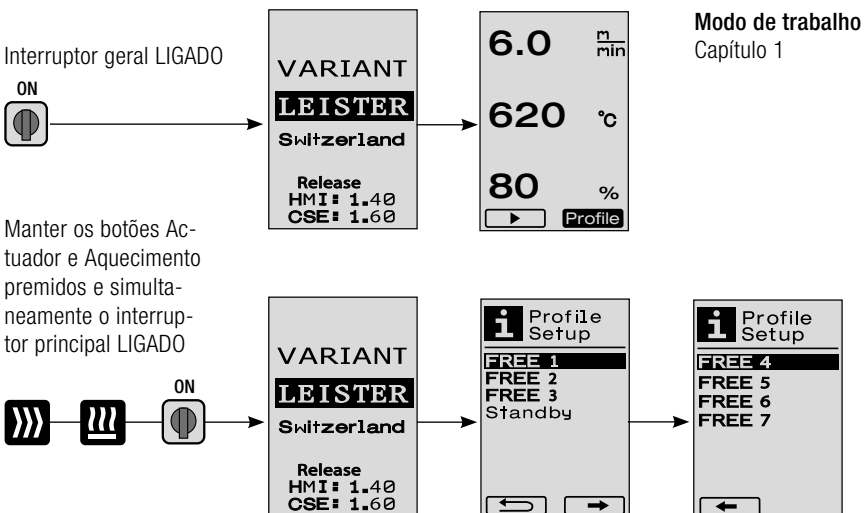

Combinação dos botões



1. Modo de trabalho

1.1 Indicação do valor nominal (após ligar o aparelho)

Interruptor principal (3) LIGADO 

- Após ligar o aparelho, aparecem os últimos valores ajustados no **visor (5)** (fig. 3).
- Neste menu, o aquecimento, ventilador e actuador encontram-se desligados.
- O utilizador pode efectuar, aqui, todos os ajustes com os **elementos de comando (4)**, que se encontram descritos nos seguintes capítulos.
- No entanto, se a temperatura do elemento de aquecimento for superior a 80°C, durante a conexão, a indicação muda para o modo Cool Down (capítulo 1.8 Arrefecer), no qual o ventilador é sempre operado com a potência máxima e, assim, o **bocal de soldadura (9)** arrefece. A partir deste modo pode ser comutado a qualquer momento para o modo de trabalho, premindo o e-Drive .
- Se a temperatura do elemento do aquecimento alcançar os 60°C durante o arrefecimento, o ventilador continua a funcionar ainda 2 minutos e de seguida desliga-se automaticamente. O **visor (5)** muda para a indicação do valor nominal (fig. 3).
- Rodando o e-Drive  para perfis podem ser seleccionados os perfis de soldadura diferentes (fig. 4; capítulo 1.7, Seleccionar perfis).

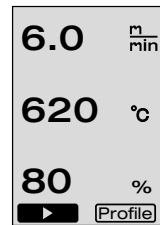



(fig. 3)



(fig. 4)

1.2 Indicação de trabalho

- Premindo o e-Drive  o aquecimento e o ventilador são iniciados e a indicação do valor nominal muda para a indicação de trabalho.
- Ao aquecer o **bocal de soldadura (9)**, isto é indicado no **visor (5)** com a barra indicadora de progresso, seta ▲ (para cima) e o valor real da temperatura de soldadura (intermitente) (fig. 5).
Se o valor nominal da temperatura de soldadura for alcançado, a seta e a barra indicadora de progresso não são mais apresentadas (fig. 6).
- Se a tensão de rede se encontrar fora (+/- 15%) da tensão nominal indicada, é apresentado alternadamente o símbolo com a sub/sobretensão  medida e a quantidade de ar ajustada. Se a quantidade de ar for de 100 %, é apresentado o símbolo com a sub/sobretensão  medida (fig. 7).
(Apenas possível no VARIANT T1 230V~).

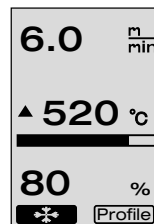

(fig. 5)

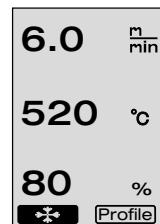

(fig. 6)

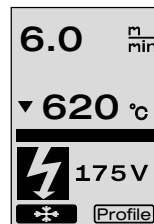

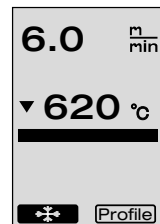

(fig. 7)



(fig. 8)













A sub/sobretensão pode influenciar o resultado da soldadura!

- Se após um tempo definido não for premido qualquer botão, **bocal de soldadura (9)** NÃO em posição de soldadura, é apresentado o menu Standby (capítulo 1.9, Standby).
- Se o **bocal de soldadura (9)** se encontrar na posição de estacionamento, os menus Cool Down (capítulo 1.8, Arrefecer) ou os perfis (capítulo 1.7, Seleccionar perfis) são seleccionáveis, rodando e-Drive .
- Se o **bocal de soldadura (9)** estiver recolhido, ambos os pontos do menu  **Profile** desaparecem do **visor (5)** e não podem ser mais seleccionados.
- Enquanto o **bocal de soldadura (9)** arrefece, isto é apresentado com a barra indicadora de progresso preenchida, a seta ▼ (para baixo) e o valor real intermitente da temperatura de soldadura no **visor (5)** (fig. 8).

1. Modo de trabalho





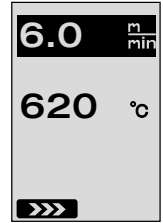

1.3 Ajuste da velocidade do actuador

- Com o botão Actuador  a velocidade do actuador pode ser adaptada. Esta pode ser regulada, rodando e-Drive  em passos de 0.1m/min. de 1.5m/min. – 18.0m/min.. Este ajuste pode ser efectuado com o actuador ligado ou desligado. Se durante 3 segundos não ocorrer qualquer introdução pelos **elementos de comando (4)**, é assumida a nova velocidade do actuador. No visor (5) aparece a indicação do valor nominal ou Cool Down (fig. 9).
- Se o **bocal de soldadura (9)** não se encontrar na posição de soldadura, aparece o símbolo (Start)  na margem inferior esquerda do visor (5).
- Rodando e-Drive , o actuador pode ser ligado, aparece o símbolo (Stop) . A velocidade do actuador pode ser ajustada directamente, rodando e-Drive .
- Rodando novamente o e-Drive  é executado o comando Stop, o actuador é desligado. No visor aparece a indicação do valor nominal ou Cool Down.
- Se o botão Actuador  for premido durante 3 segundos, a indicação muda para um outro menu (ver capítulo 1.6 Medição longitudinal, contador do ventilador e do actuador).
- Com o botão Aquecimento  ou o botão Ventilador  pode ser mudado para o respectivo menu.



(fig. 9)

1.4 Ajuste da temperatura de soldadura

- Com o botão Aquecimento  pode ser alterada a temperatura de soldadura. A temperatura de soldadura é ajustável em passos de 10°C de 100°C – 620°C, rodando e-Drive . O ajuste é assumido após 3 segundos, desde que dentro destes 3 segundos não for accionado qualquer botão (fig. 10).
- Se este menu for consultado a partir da indicação do valor nominal, premindo e-Drive , o aquecimento e o ventilador podem ser iniciados. Se o aquecimento estiver ligado, o menu Cool Down pode ser seleccionado (capítulo 1.8, Arrefecer) (fig. 11).
- Premindo o botão Aquecimento  durante 3 segundos, aparece a tensão de rede por baixo da velocidade do actuador. Esta consulta apenas é possível a partir da indicação de trabalho (capítulo 1.2). (Apenas possível no VARIANT T1 230V~).
- Com o botão Actuador  ou o botão Ventilador  pode ser mudado para o respectivo menu.

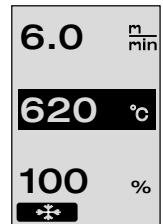



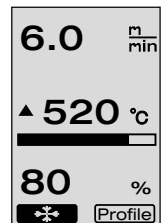



(fig. 10)



(fig. 11)

1. Modo de trabalho



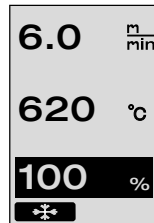

1.5 Ajuste da quantidade de ar

- Com o botão ventilador , a quantidade de ar pode ser alterada. A quantidade de ar é ajustável em passos de 5% de 40% – 100%, rodando e-Drive . O ajuste é assumido após 3 segundos, desde que dentro destes 3 segundos não for accionado qualquer botão. Se a quantidade de ar estiver ajustada em 100%, não aparece qualquer indicação no visor (5) (fig 12).
- Se este menu for consultado a partir da indicação do valor nominal, premindo e-Drive , o aquecimento e o ventilador podem ser iniciados.
- O menu Cool Down pode ser seleccionado, premindo e-Drive  (Capítulo 1.8, Arrefecer).
- Com o botão Actuador  ou o botão Aquecimento  pode ser mudado para o respectivo menu.



(fig. 12)

1.6 Medição longitudinal, contador de ventilador e de actuador



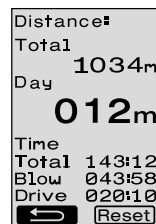







- Este menu (fig. 13) aparece, se o botão Actuador  for premido, no mínimo, 3 segundos.
- O menu apresenta vários horários de funcionamento e a distância, que o aparelho percorreu desde que foi ligado. A distância completa (aqui: 1034m) não é alterável e apresenta todo o percurso percorrido desde a colocação em funcionamento.
- A distância diária (aqui: 012 m) não é automaticamente reposta, mas pode ser reposta para zero pelo utilizador através de **Reset**, premindo e-Drive .
- Relativamente aos valores Time trata-se do horário de funcionamento dos componentes individuais do aparelho. Sendo o tempo atribuído ao ventilador «Blow» (aqui: 043:58) e ao actuador «Drive» (aqui: 020:10). O tempo «Total» refere-se ao horário de funcionamento. Este conta as horas e os minutos (aqui: 143:12), enquanto o **interruptor principal (3)** estiver ligado.
- Se premindo e-Drive  for seleccionada a seta Back (retroceder)  regressa-se ao menu, a partir do qual foi premido o botão Actuador .



(fig. 13)

1. Modo de trabalho

1.7 Seleccionar perfis

- Se a indicação **Profile** à direita em baixo no **visor (5)** estiver activa, podem ser carregados perfis, premindo e-Drive . De seguida aparece a indicação «Select Profile». Rodando e-Drive  pode ser seleccionado um perfil. Os perfis FREE 1–7 podem ser definidos pelo utilizador (ver capítulo 2 Setup dos perfis). Todos os outros perfis têm valores fixamente atribuídos e podem ser definidos pelo utilizador (fig 14).
- Rodando e-Drive  podem ser activadas, no **visor (5)** em baixo à esquerda ou direita, as setas.
Seta direita  premindo e-Drive  para a próxima página (fig 15).
Seta esquerda  premindo e-Drive  para a página anterior (fig 16).
- Se for activada a seta Back (retroceder) , rodando e-Drive  regressa-se, premindo e-Drive  ao menu, a partir do qual foi seleccionado perfis

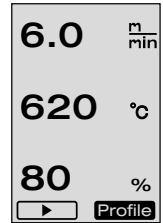

(fig. 14)

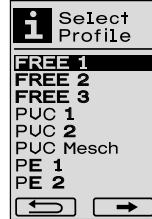

(fig. 15)

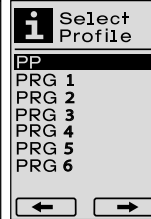







(fig. 16)



Proceder à soldagem de teste de acordo com o fabricante do material e as normas ou directivas nacionais. Verificar soldagem de teste.

1.8 Arrefecer

- Se for seleccionado o símbolo , premindo e-Drive  (fig 17), aparece o menu «Cool down OK?» (Fig 18). Premindo e-Drive  é activado o símbolo OK na margem inferior à direita no **visor (5)**. Assim é induzido o processo de arrefecimento.
- Durante o processo de arrefecimento a quantidade de ar é aumentada para 100% e a temperatura de soldadura actual de soldadura (fig 19).
Se a temperatura de soldadura de 60°C não for alcançada, o ventilador continua a funcionar 2 minutos e desliga-se automaticamente após decorrer este tempo.
A indicação muda para a indicação do valor nominal.
- Premindo e-Drive  durante o processo de arrefecimento, o aquecimento é iniciado e no **visor (5)** aparece a indicação de trabalho (ver capítulo 1.2 Indicação de trabalho).
- Se o menu Cool Down estiver activo, o actuador pode ser ligado/desligado manualmente através do botão Actuador . Os botões Aquecimento  e Ventilador  não possuem qualquer função.

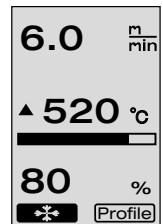

(fig. 17)



(fig. 18)

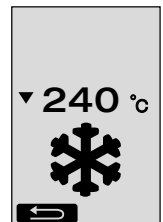

(fig. 19)

1. Modo de trabalho

1.9 Standby

- Se o **bocal de soldadura (9)** não se encontrar na posição de soldadura e se não ocorrer qualquer introdução de botão durante o tempo Standby definido pelo utilizador, o modo Cool Down inicia automaticamente após decorrer o Countdown (fig 20). O processo de arrefecimento é induzido.
- Se antes do tempo de corrido para o Countdowns (180 segundos) for premido e-Drive , o **visor (5)** muda para a indicação de trabalho (ver capítulo 1.2 Indicação de trabalho).
- Ajuste do tempo Standby (capítulo 2.3, Standby Setup).

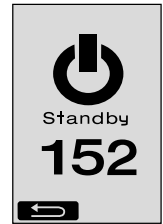

(fig. 20)

1.10 Mensagem de erro

- Se surgir uma falha na máquina de soldadura a ar quente VARIANT T1, aparece no **visor (5)** uma mensagem, à qual é atribuído adicionalmente um código de erro. Este código representa uma descrição precisa do erro, que se encontra visível na lista em baixo.
- No erro 02 e no erro 40 são apresentados símbolos separados
- Em caso de todos os outros erros é apresentada chave de parafusos para o pedido de assistência

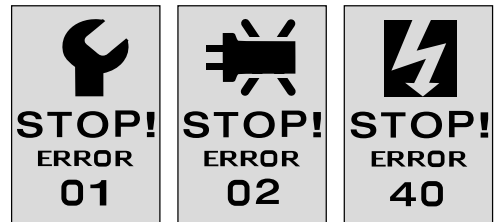

Error	Tipo do erro
Err00	Electrónica dos comandos avariada
Err01	Interrupção ou curto-circuito da sonda de temperatura
Err02	Elemento de aquecimento / electrónica avariada (interrupção em um/ambos enrolamento/s)
Err04	Triac avariado (um ou ambos os Triacs avariados)
Err08	Motor do ventilador avariado
Err40	Subtensão 25% (tensão de rede 75%) apenas VARIANT T1 230V~

2. Setup de perfis



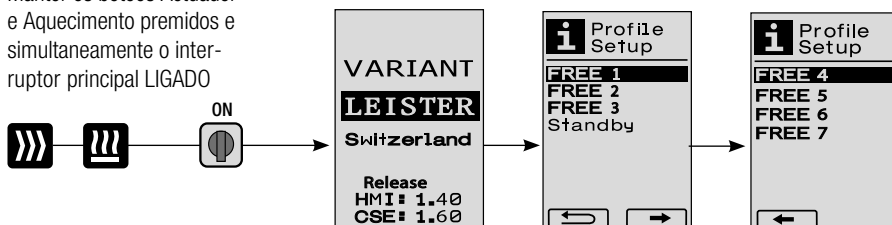

2.1 Setup de perfis Combinação de botões

Manter os botões Actuador e Aquecimento premidos e simultaneamente o interruptor principal LIGADO



2. Setup de perfis

2.2 Criar perfis

- No Setup de perfis podem ser criados 7 perfis individuais, nos quais podem ser livremente ajustados o nome, e todos os três parâmetros Actuador  Aquecimento , Ventilador  e de seguida, premindo e-Drive  podem ser memorizados (fig.21).

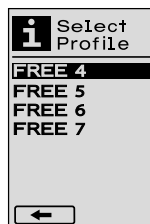







(fig. 21)



- Os diferentes pontos do menu podem ser seleccionados através dos elementos de comando (4). Premindo e-Drive  regressa-se à selecção Setup de perfis.



- Rodando e-Drive  podem ser activadas, no visor (5) em baixo à esquerda ou direita, as setas.

Seta direita  premindo e-Drive  para a próxima página (fig 15).



Seta esquerda  premindo e-Drive  para a página anterior (fig 16).



- Se for activado o símbolo  ABC, rodando e-Drive  entra-se no menu Nome do perfil, premindo e-Drive  (fig. 22).
- No menu Nome do perfil podem ser seleccionados, rodando e-Drive , o carácter **_ / . / A Z / 0 a 9**, bem como as setas esquerda ou direita e os símbolos Save  ou Back .
- Alterar nome do perfil

- Rodando e-Drive  podem ser seleccionadas as setas à esquerda ou direita. Se a seta for activada, premindo e-Drive , a posição salta, no Nome do perfil, um carácter (preto) para a direita. Se a seta for activada, premindo e-Drive , a posição salta, no Nome do perfil, um carácter (preto) para a esquerda (fig 23).

- Rodando e-Drive  pode ser seleccionado o carácter desejado (**_ / . / A a Z / 0 a 9**). Premindo e-Drive  o carácter apresentado a preto no Nome do perfil é substituído pelo carácter anteriormente seleccionado.

- Memorizar ou ignorar Nome do perfil

- Se, rodando e-Drive  for seleccionado o símbolo Save , o Nome do perfil é memorizado, premindo e-Drive .

- Se, rodando e-Drive  for seleccionado o símbolo Back , o Nome do perfil é ignorado (não memorizado), premindo e-Drive .

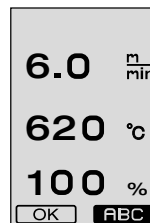

(fig. 22)



(fig. 23)



Proceder à soldagem de teste de acordo com o manual de soldadura do fabricante do material e as normas ou directivas nacionais. Verificar soldagem de teste.

2.3 Standby Setup

- O tempo Standby define o tempo que tem de decorrer (nenhuma introdução do botão, **bocal de soldadura (9)** não se encontra na posição de soldadura), até que o processo de arrefecimento seja activado automaticamente (ver capítulo 1.8 Arrefecer).

- Rodando e-Drive  pode ser ajustado o tempo de 5 – 120 minutos. De fábrica estão ajustados 40 minutos.

- Premindo e-Drive  regressa-se à selecção Setup de perfis.



FAQ (Perguntas frequentes) Erro – Causa – Medida

- Máquina desliga-se automaticamente
 - Com o funcionamento Standby, a máquina é desligada automaticamente após tempo ajustado (de fábrica estão ajustados 40 minutos).
 - Em caso de necessidade aumentar tempo Standby (página 105, 2. Setup de perfis, 2.3 Standby Setup).
- Qualidade da soldadura é má
 - Verificar velocidade do actuador, temperatura de soldadura e quantidade do ar
 - Limpar **bocal de soldadura (9)** com escova de arame
 - O **bocal de soldadura (9)** está ajustada incorrectamente

Proceder ajuste do bocal da soldadura (9) da seguinte forma

- Arrefecer **bocal de soldadura (9)** (página 103, 1. Modo de trabalho, 1.8 Arrefecer)
- Soltar os parafusos sextavados no suporte do aparelho
- Proceder ao ajuste angular através dos movimentos oscilantes no **ventilador do ar quente (8)**.
- O **bocal de soldadura (9)** tem de ser encontrar (**seta E**) no **calibre do bocal (34)** e (**seta D**) na base.
- Apertar os parafusos sextavados no suporte do aparelho
- Colocar o **calibre do bocal (34)** na posição. Considerar escala no **calibre do bocal (34)**
- Colocar **ventilador do ar quente (8)** na posição de soldadura
- Soltar os parafusos de ajuste do **eixo oscilante (25)**
- Alinhar paralelamente o **ventilador de ar quente (8)** no **calibre do bocal (34)**
- Apertar os parafusos de ajuste do **eixo oscilante (25)**
- Remover **calibre do bocal (34)** e efectuar a soldagem de teste.

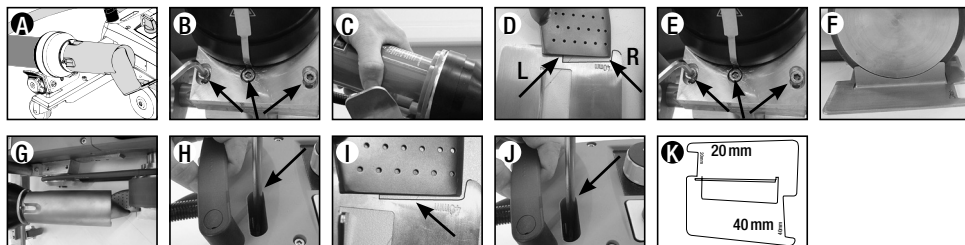

- O não alcance da temperatura ajustada (indicação da temperatura pisca)
 - Controlar tensão de rede
 - Reduzir quantidade de ar
 - Reduzir temperatura
- O ventilador do ar quente não bloqueia na posição de soldadura
 - Peça de pressão esférica tem de ser ajustada da seguinte forma:
 - Arrefecer **bocal de soldadura (9)** (Página 103, 1. Modo de trabalho, 1.8 Arrefecer)
 - Colocar o **bocal de soldadura (9)** na posição de soldadura
 - Apertar ligeiramente o **parafuso (30)**, depois retornar o **parafuso (30)** aprox. 1/2 rotação.

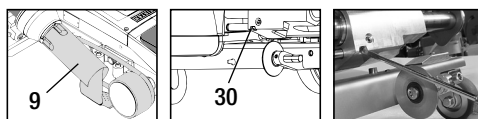

FAQ (Perguntas frequentes) Erro – Causa – Medida

- A largura da costura de soldadura não é constante
 - Proceder o ajuste preciso do rolo guia da seguinte forma:
 - Arrefecer **bocal de soldadura (9)**
(Página 103, 1. Modo de trabalho, 1.8 Arrefecer)
 - Colocar o **bocal de soldadura (9)** na posição de soldadura
 - Soltar parafuso sextavado do **rolo guia (15)**
 - Deslocar **rolo guia (15)** para a posição desejada
 - Apertar parafuso sextavado
 - Efectuar a soldagem de teste

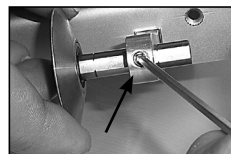
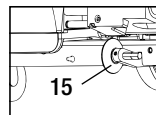
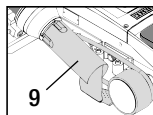



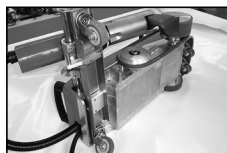
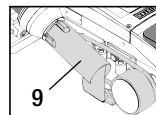
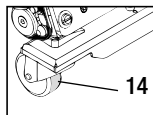

- A máquina de soldadura a ar quente afasta-se da costura (soldadura sobreposta)
 - Efectuar o ajuste preciso da faixa do **rolo oscilante (14)** da seguinte forma:
 - Arrefecer **bocal de soldadura (9)**
(Página 103, 1. Modo de trabalho, 1.8 Arrefecer)
 - Desligar **interruptor principal (3)** OFF
 - Separar cabo de alimentação da rede eléctrica
 - Remover **peso adicional (16)**
 - Inclinar lateralmente a máquina de soldar
 - Soltar **parafuso de bloqueio para ajuste preciso da faixa (31)** e colocar a **alavanca para ajuste preciso da faixa (32)** na posição desejada
 - Apertar **parafuso de bloqueio para ajuste preciso da faixa (31)**
 - Colocar a máquina de soldadura a ar quente na posição de soldadura
 - Colocar **peso adicional (16)**
 - Voltar a colocar a máquina de soldadura a ar quente em funcionamento
 - Efectuar a soldagem de teste

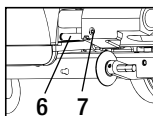
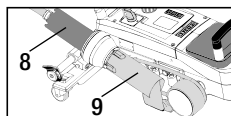
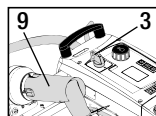

- Automatismo de arranque não funciona
 - Se o motor do actuador não iniciar automaticamente após o arranque do **bocal de soldadura (9)**, o **sensor de arranque (6)** provavelmente está ajustado incorrectamente.
 - Ajustar **sensor de arranque (6)** da seguinte forma:
 - Arrefecer **bocal de soldadura (9)** (página 103, 1. Modo de trabalho, 1.8 Arrefecer)
 - Desligar **interruptor principal (3)**
 - Oscilar e encaixar o **bocal de soldadura (9)** através do **ventilador de ar quente (8)** para a posição de soldadura.
 - proceder ao ajuste do **sensor de arranque (6)** no **perno roscado (7)** com a chave Allen;
IMPORTANTE: Distância de comutação 0.2 – 0.5mm
 - Verificar função



Se o motor do actuador mesmo assim não arrancar automaticamente, deve entrar-se em contacto com o ponto de assistência

	Sobreposição	Bainha	Bainha aberta (até 70mm)	Fio Keder	Keder pré-preparado
 <p>Versão padrão</p>	●	●	●		
 <p>Componente bainha/Keder</p>		●	●	●	
 <p>Placa de sustentação</p>		●		●	●
 <p>Guia Keder</p>				●	●

Aplicação

Em vez do rolo guia (15) também pode ser trabalhado como componente bainha/Keder.

Também possível com Versão padrão e fixação do tolde.

Também possível com Versão padrão e fixação do tolde.

Recomenda-se base com ranhura longitudinal para Keder.

Fixação sem dobras dos Keder pré-preparados.

Tipo

Boa fixação do tolde.

Marcação da sobreposição da bainha para melhor controle de guiamento.

Marcação da sobreposição da bainha para melhor controle de guiamento.

Marcação da sobreposição da bainha para melhor controle de guiamento. Deixar funcionar o aparelho livremente, guiamento manual do tolde com Keder

Versões Leister VARIANT T1

- N.º de artigo 141.891 VARIANT T1, 230 V / 40 mm bocal de soldadura / com ficha Euro
- N.º de artigo 141.892 VARIANT T1, 230 V / 20 mm bocal de soldadura / com ficha Euro
- N.º de artigo 141.893 VARIANT T1, 400 V / 40 mm bocal de soldadura / com ficha CEE (3LNPE)
- N.º de artigo 141.894 VARIANT T1, 400 V / 20 mm bocal de soldadura / com ficha CEE (3LNPE)
- N.º de artigo 147.739 VARIANT T1, 200 V / 40 mm bocal de soldadura / sem ficha
- N.º de artigo 147.748 VARIANT T1, 200 V / 20 mm bocal de soldadura / sem ficha

Acessórios

Por motivos técnicos e relevantes de segurança apenas podem ser utilizados acessórios da Leister.

- | | |
|--|---|
| N.º de artigo 142.650 kit de bainha / Keder completo | N.º de artigo 139.438 peso adic |
| N.º de artigo 140.530 componentes da bainha / Keder | N.º de artigo 137.843 pega T parte superior da vareta de guia |
| N.º de artigo 142.221 placa de sustentação | N.º de artigo 116.798 escova em latão |
| N.º de artigo 141.326 guia Keder | N.º de artigo 142.705 mala Keder |

Formação

- Leister Technologies AG e o seu ponto de assistência autorizado oferecem cursos de soldagem e formações gratuitas. Informações em www.leister.com.

Manutenção

- A entrada do ar no **ventilador do ar quente (8)** deve ser limpa com um pincel em caso de sujidade
- Limpar **bocal de soldadura (9)** com escova em latão
- Verificar **cabo de alimentação (1)** e ficha quanto a danos eléctricos e mecânicos.

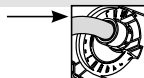

Assistência e reparação

- Se o contador do actuador alcançar 400h ou o contador do ventilador 2000h, aparece no **visor (5)**, na próxima conexão do **interruptor principal (3)** a mensagem «**Maintenance servicing**». Esta mensagem é apresentada 10 segundos e não pode ser passada à frente através dos **elementos de comando (4)**.
- As reparações devem ser efectuadas apenas por **pontos de assistência da Leister** autorizados. Estes garantem **dentro de 24 horas** um **serviço de reparação** especializado e fiável com peças de substituição originais de acordo com os esquemas eléctricos e listas de peças de substituição.

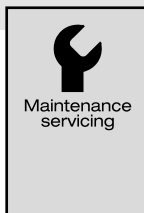

Garantia

- Para este aparelho são válidos os direitos de garantia e de garantia adicional assegurados diretamente pelo distribuidor/vendedor, a partir da data de compra. No caso de uma reivindicação de garantia ou garantia adicional (comprovação através de nota fiscal ou nota de entrega) as falhas do fabricante ou de montagem do distribuidor são corrigidas com o fornecimento de peças de reposição ou reparo. As resistências estão excluídas da garantia ou garantia adicional.
- Outras pretensões de garantia ou garantia adicional ficam excluídas, no âmbito do direito imperativo.
- Danos causados por desgaste natural, sobrecarga ou manuseio incorreto estão excluídos da garantia.
- Não existe direito a reclamação ao abrigo da garantia ou garantia adicional em casos em que os aparelhos tenham sido reformados ou modificados pelo comprador.

Wij feliciteren u met de aankoop van de hetelucht-lasautomaat VARIANT T1

U heeft gekozen voor een eerste klas hetelucht-lasautomaat, die uit hoogwaardige materialen is samengesteld. Dit apparaat werd volgens de nieuwste lastechnologie ontwikkeld en geproduceerd. Elke VARIANT T1 wordt aan een strenge kwaliteitscontrole onderworpen voordat hij de fabriek in Zwitserland verlaat.

Inhoudsopgave

Aanwending, Waarschuwing, Veiligheid	pagina	111
Conformiteit, Afvalverwerking, Technische gegevens	pagina	112
Beschrijving van het apparaat, Bedieningselementen	pagina	113
Info icons, Actieve icons, Quick-info	pagina	114
Bedrijfsklaar maken, In positie brengen van het apparaat	pagina	115
Afloop lasproces	pagina	116
Transportklaar maken, Toetsencombinaties	pagina	117
Functiemodus (hoofdstuk 1)		
1.1 Weergave instelwaarden		
1.2 Toestandswaergave	pagina	118
1.3 Instellen van de aandrijfsnelheid		
1.4 Instellen van de lastemperatuur	pagina	119
1.5 Instellen van de luchtstroom		
1.6 Lengtemeting, ventilator- en aandrijvingscounter	pagina	120
1.7 Profielen selecteren		
1.8 Afkoelen	pagina	121
1.9 Standby		
1.10 Storingmeldingen		
Profile Setup (hoofdstuk 2)		
2.1 Profile Setup toetsencombinatie	pagina	122
2.2 Profielen vastleggen		
2.3 Standby Setup	pagina	123
FAQ	pagina	124/125
Lastoepassingen	pagina	126
Uitvoeringen, Toebehoren, Bijscholing, Onderhoud, Service en reparatie, Garantie	pagina	127



Bedieningshandleiding vóór de inwerkingstelling aandachtig lezen en voor later gebruik bewaren.

Leister VARIANT T1 Hetelucht-lasautomaat

Aanwending

Gebruik het apparaat uitsluitend in goed geventileerde ruimten. Indien nodig moet met een afzuiginstallatie of persoonlijke beschermuitrusting worden gewerkt. Let erop dat het materiaal tijdens het lassen niet verbrandt. Controleer met de producent van het materiaal of het materiaal schadelijke additieven bevat. De wettelijke bepalingen met betrekking tot de gezondheid, die in het specifiek land geldig zijn, moeten worden toegepast.

- Handgeleide hetelucht-lasautomaat voor overlappings-, zoom- en boordsel-lasnaden van dekzeilmateriaal (PVC en soortgelijke materialen).
- **Verwerking alleen in goed geventileerde ruimtes**



Waarschuwing



Levensgevaar bij het openen van het apparaat, omdat onder spanning staande onderdelen en aansluitingen worden blootgelegd. Vóór het openen van het apparaat eerst de stekker uit het stopcontact trekken.



Brand- en ontploffingsgevaar bij ondeskundig gebruik van heteluchtapparaten, vooral in de buurt van brandbare materialen en explosieve gassen.



Verbrandingsgevaar! Lasmondstuk niet in hete toestand aanraken. Het apparaat eerst laten afkoelen.
De hete luchtstraal niet op personen of dieren richten.



Sluit het apparaat alleen aan een geaard stopcontact aan. Elke onderbreking van de aardleiding binnen of buiten het apparaat is gevaarlijk!
Alleen verlengsnoeren met aardleiding gebruiken!



Veiligheid



De **nominale spanning** die op het apparaat staat aangegeven moet overeenkomen met de netspanning. EN 61000-3-11; $Z_{max} = 0.164 \Omega + j 0.102 \Omega$. neem in voorkomende gevallen contact op met uw energie-leverancier.
Bij een **netuitval** heteluchtventilator uitschakelen.



Een **aardlekschakelaar** is bij het gebruik van het apparaat op bouwplaatsen ter beveiliging van personen dringend noodzakelijk.



Het apparaat **moet onder toezicht** in werking zijn. De warmte kan brandbare materialen bereiken die zich buiten zichtwijdte bevinden.

Het apparaat mag alleen door daarvoor **opgeleide technici** of onder toezicht van zulke personen worden gebruikt. Het is kinderen verboden het apparaat te gebruiken.



Bescherm het apparaat **tegen vocht en damp**.



Het apparaat mag niet aan het ballastgewicht worden opgeheven.

Conformiteit

Leister Technologies AG, Galileo-Strasse 10, CH-6056 Kaegiswil/Zwitserland bevestigt dat dit product in de door ons in omloop gebrachte uitvoering aan de eisen van de volgende EU-richtlijnen voldoet.

Richtlijnen: 2006/42/EC, 2014/30/EU, 2011/65/EU
Geharmoniseerde normen: EN ISO 12100, EN 55014-1, EN 55014-2, EN 61000-3-2, EN 61000-3-3, EN 61000-3-11 (Z_{max}), EN 61000-6-2, EN 62233, EN 60335-1, EN 60335-2-45, EN IEC 63000

Kaegiswil, 05.11.2020

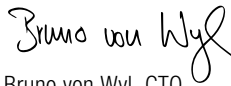
Bruno von Wyl, CTO



Christoph Baumgartner, GM

Afvalverwijdering



Bied elektrische toestellen, toebehoren en verpakkingen aan voor milieuvriendelijk hergebruik. Voer het elektrische toestellen niet af via de inzameling van huishoudelijk afval!

Technische gegevens

Spanning	V~	200	230	400 (2LNPE)	V~	200	230	400 (2LNPE)
Vermogen	W	4200	3680	5700	W	4200	3680	5700
Frequentie	Hz	50/60			Hz	50/60		
Temperatuur	°C	100 – 620 traploos			°F	212 – 1148 traploos		
Aandrijving	m/min.	1.5 – 18 traploos			ft/min	4.9 – 59.1 traploos		
Luchtstroom	%	40 – 100			%	40 – 100		
Geluidspiek	L _{pA} (dB)	70			L _{pA} (dB)	70		
Gewicht	kg	22			lbs	48.5		
zonder netsnoer								
Maten L × B × H	mm	500 × 400 × 195			inch	19.7 × 15.8 × 7.7		
Conformiteitsteken		CE				CE		
Beschermingsklasse I								

Aansluitspanning niet omschakelbaar

Technische wijzigingen voorbehouden

Beschrijving van het apparaat

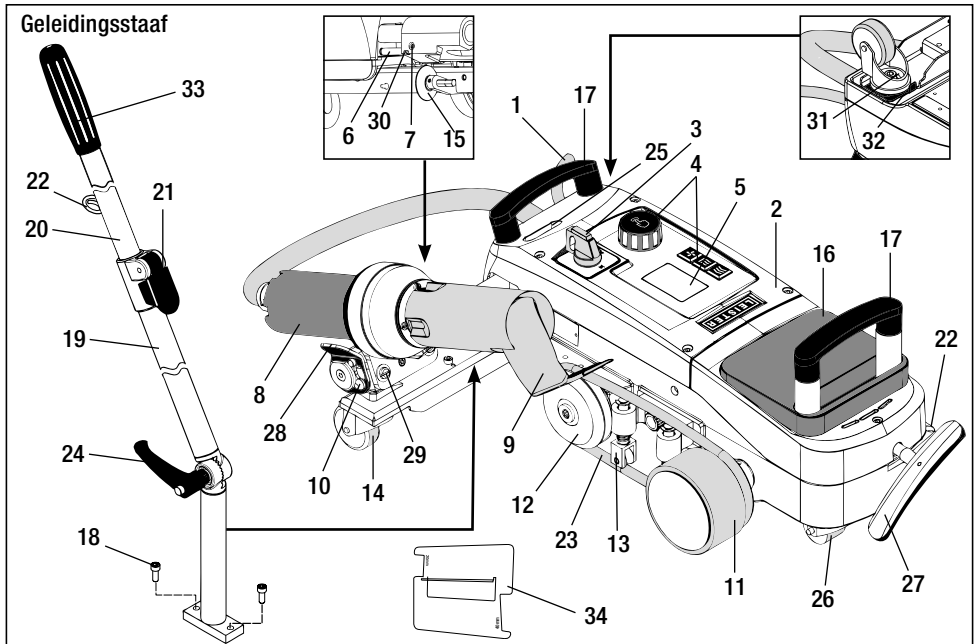

- | | | |
|--|---|--|
| 1 Netsnoer | 12 Omkeerrol | 24 Greepschroef
onderste deel geleidingsstaaf |
| 2 Huis | 13 Neerdrucker | 25 Instelschroeven zwenkas |
| 3 Hoofdschakelaar | 14 Stuurrol | 26 Transportrol |
| 4 Bedieningselementen | 15 Geleidingsrol | 27 Greep voor hefmechanisme |
| 5 Display | 16 Ballastgewicht | 28 Sluitgreep |
| 6 Rolsensor | 17 Draaggreep | 29 Hoekinstelling apparaathouder |
| 7 Schroefdraadpen voor
instelling rolsensor | 18 Cilinderkopbout | 30 Arrêteerschroef voor laspositie |
| 8 Heteluchtventilator | 19 Onderste deel geleidingsstaaf | 31 Arrêteerschroef voor fijne
spoorinstelling |
| 9 Lasmondstuk | 20 Bovenste deel geleidingsstaaf | 32 Hefboom voor fijne spoorinstelling |
| 10 Arrêteerpal voor
heteluchtventilator | 21 Klemhefboom
bovenste deel geleidingsstaaf | 33 Greep geleidingsstaaf |
| 11 Aandrukrol | 22 Houder voor netsnoer | 34 Mondstukkaliber |
| | 23 Ronde riem | |

Hoofdschakelaar (3)



Voor het in- / uitschakelen van de hetelucht-lasautomaat VARIANT T1

Bedieningselementen (4)



e-Drive

De e-Drive dient als navigator.

Deze heeft twee functies:



Naar links of rechts draaien, om diverse menu's of waarden in te stellen



Indrukken, om te bevestigen of te activeren



Aandrijving

Instellen van de aandrijfsnelheid



Verwarming

Instellen van de lastemperatuur



Ventilator

Instellen van de luchtstroom

Info Icons

De volgende icons worden ter informatie op de display weergegeven.



Lasmondstuk koelt af



Apparaat in de standby-modus, apparaat schakelt zich na afloop hiervan uit



Contact opnemen met een geautoriseerd servicepunt



Geeft aan dat de temperatuur stijgt



Geeft aan dat de temperatuur zinkt



Progressiebalk

Aktieve icons

De volgende icons worden op de display weergegeven en door indrukken van de e-Drive geactiveerd.



Inschakelen van verwarming en ventilator (indien de ventilator nog niet loopt)



Aandrijving stoppen



Aandrijving starten



Automatisch afkoelen (verwarming uit, ventilator aan)



Binnen de menustructuur naar boven (terug naar het vorige programma)



Enter, Bevestigen



Profielen selecteren



Veranderde naam opslaan



Profielnaam veranderen



Naar de volgende pagina



Naar de volgende pagina



Dagafstand op nul zetten

Info icons



Aktieve icons

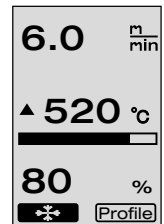
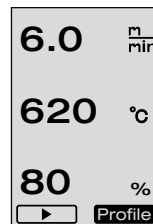
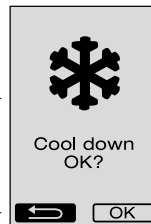
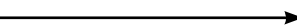

Quick Info

Hoe start ik de hetelucht-lasautomaat VARIANT T1?

1. Netsnoer aan het lichtnet aansluiten
2. Hoofdschakelaar (3) AAN
3. Toets Aandrijving indrukken → e-Drive verdraaien
4. Toets Verwarming indrukken → e-Drive verdraaien
5. Toets Ventilator indrukken → e-Drive verdraaien
6. e-Drive indrukken opwarmtijd ca. 1 – 2 minuten →
7. Testlas volgens lashandleiding van de materiaalfabrikant en nationale normen of richtlijnen uitvoeren. Testlas controleren.
8. Las

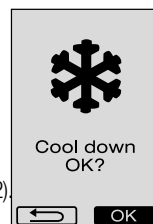
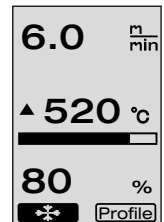

(afb. 1)

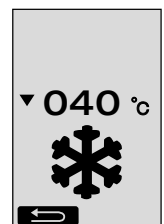

(afb. 2)

Hoe schakel ik de hetelucht-lasautomaat VARIANT T1 uit?

1. e-Drive indrukken (afb. 1).
2. «Cool down OK» e-Drive indrukken en ca. 4 minuten laten afkoelen (afb. 2). Ventilator schakelt zich automatisch uit.
3. Nadat lasmondstuk (9) is afgekoeld hoofdschakelaar (3) UIT

Bedrijfsklaar maken

- Vóór inbedrijfstelling **netsnoer (1)** en stekker, evenals verlengsnoer op elektrische en mechanische beschadiging controleren.
- De basisinstelling van het **lasmondstuk (9)** wordt in de fabriek uitgevoerd
- Basisinstelling van het **lasmondstuk (9)** controleren
 - De controle kan met **mondstukkaliber (34)** of volgens detail A en B plaatsvinden.

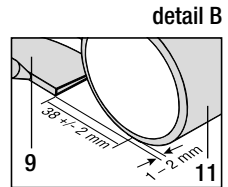
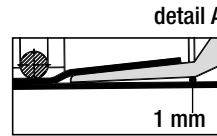
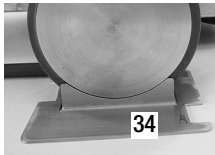

- **Geleidingsstaaf** met **cilinderkopbouten (18)** monteren.
 - **Onderste deel geleidingsstaaf (19)** met **greepschroef (24)** en **bovenste deel geleidingsstaaf (20)** met **klemhefboom (21)** in de gewenste positie brengen.
 - Snoerontlasting van **netsnoer (1)** in **houder (22)** van de geleidingsstaaf of aan het chassis bevestigen.

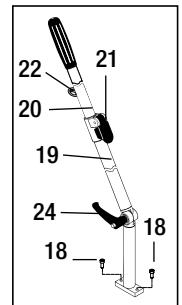

- **Ballastgewicht (16)** aanbrengen (max. twee ballastgewichten)

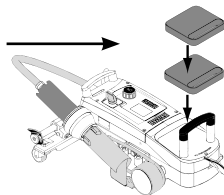

Apparaat aan het lichtnet aansluiten. De nominale spanning die op het apparaat staat aangegeven, moet overeenkomen met de netspanning.
Bij **netuitval heteluchtventilator (8)** in parkeerpositie brengen.

In positie brengen van het apparaat

- Het dekzeilmateriaal moet onder de overlapping en aan de boven- en onderzijde schoon zijn.
- **Lasmondstuk (9)**, **aandrukrol (11)**, **omkeerrol (12)** en **ronde riem (23)**, evenals **neerdrucker (13)** moeten schoon zijn.
- Wanneer de hetelucht-lasautomaat niet transportklaar is, moet het apparaat met de **greep (27)** van het heftoestel worden opgeheven. De **transportrollen (26)** zijn nu in functie.
- Hetelucht-lasautomaat naar de lasplaats rollen.
- Met de **greep (27)** de hetelucht-lasautomaat tot op de laspositie laten zakken. De **transportrollen (26)** hebben nu geen functie meer en zijn dus ontlast.
- **Geleidingsrol (15)** naar onder draaien
- **Geleidingsrol (15)** moet evenwijdig aan de **aandrukrol (11)** staan (detail C).

Transportklaar:
greep naar links

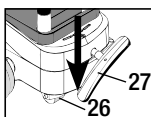

In laspositie:
greep naar rechts

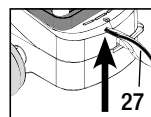

detail C

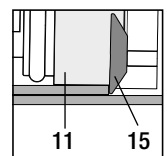

Afloop lasproces

• Voorbereiding



Testlas volgens lashandleiding van de materiaalfabrikant en de nationale normen of richtlijnen uitvoeren. Testlas controleren.

- Lasparameters Aandrijving, Verwarming en Ventilator instellen (hoofdstuk 1, Functiemodus)
- Lastemperatuur moet bereikt zijn (opwarmtijd ca. 1–2 min.)

• Start lasproces

- Geleidingsrol (15) naar onder draaien
- Heteluchtventilator (8) iets omhoog- en naar binnen zwenken, tot de arrêteerpal (10) uit de uitsparing is geschoven. Heteluchtventilator (8) onmiddellijk naar omlaag brengen.



OPGELET: Indien de heteluchtventilator (8) te ver naar binnen en naar omlaag wordt verschoven, komen het lasmondstuk (9) en de aandrukrol (11) met elkaar in contact. Dan kan de heteluchtventilator (8) niet verlaagd worden.

- Bovenste dekzeilmateriaal bij de geleidingsrol iets opheffen en door verschuiven van de heteluchtventilator (8) het lasmondstuk (9) tussen de overlappende dekzeilen tot aan de aanslag naar binnen trekken.



- Aandrijfmotor start automatisch. Geen automatische start (hoofdstuk FAQ, pagina 125)
- Machine kan met bedieningselementen (4) Aandrijving  en e-Drive  per hand worden gestart
- Wordt de aandrijving via  en e-Drive  gestart en daarna het lasmondstuk (9) naar binnen geschoven, dan loopt de hetelucht-lasautomaat na het uitzwenken van het lasmondstuk (9) ca. 30 cm door (vertraagd uitschakelen van de aandrijving).
- De hetelucht-lasautomaat kan met de greep aan de geleidingsstaaf (33), de draaggreep (17), of aan de sluitgreep (28) langs de overlapping worden gevoerd. Voer de hetelucht-lasautomaat bij het lassen zonder te drukken op de greep van de geleidingsstaaf (33), op de draaggreep (17) of op de sluitgreep (28). Drukken kan tot lasfouten leiden. Let op de positie van de geleidingsrol (15).

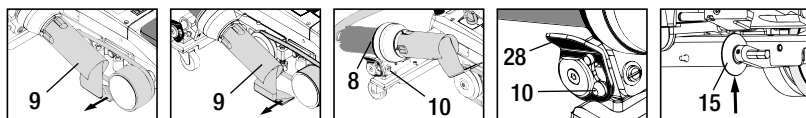

• Einde van het lasproces

- Na het lassen het lasmondstuk (9) met de heteluchtventilator (8) vanuit de laspositie naar rechts schuiven en omhoog bewegen.
- De heteluchtventilator (8) naar rechts schuiven tot de arrêteerpal (10) in de uitsparing van de sluitgreep (28) valt. De heteluchtventilator (8) is nu in parkeerpositie.
- Geleidingsrol (15) naar boven zwenken

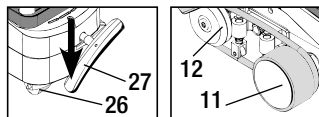

- Verlagen van de transportrollen (26) door verdraaien van de greep (27). Daardoor worden de aandrukrol (11) en de omkeerrol (12) voor het transport ontlast.



- Na afloop van het laswerk met e-Drive   (2 x indrukken) de verwarming uitschakelen, daardoor wordt het lasmondstuk (9) afgekoeld en de ventilator wordt na ca. 4 minuten automatisch uitgeschakeld (hoofdstuk 1.8, Afkoelen).
- Hoofdschakelaar (3) uitschakelen OFF 



Netsnoer van het lichtnet scheiden.

- Lasmondstuk (9) met messing borstel reinigen

Transportklaar maken

- Geleidingsrol (15) naar boven zwenken.
- Heteluchtventilator (8) naar rechts schuiven tot de arrêteerpal (10) in de uitsparing van de sluitgreep (28) valt. Heteluchtventilator (8) is nu in parkeerpositie.
- Verlagen van de transportrollen (26) door verdraaien van de greep (27). Daardoor worden de aandrukrol (11) en de omkeerrol (12) voor het transport ontlast.

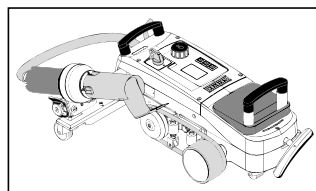
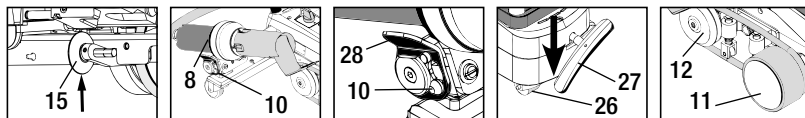

Rollen



Dragen

Toetsencombinaties

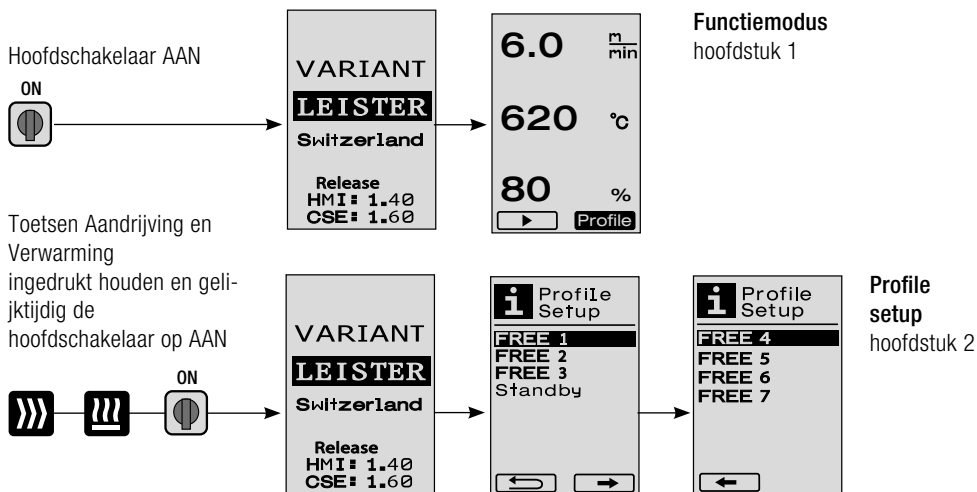

1. Functiemodus

1.1 Weergave instelwaarden (na het inschakelen van het apparaat)

Hoofdschakelaar (3) AAN

- Na het inschakelen van het apparaat verschijnen de laatste instelwaarden op de **display (5)** (afb. 3).
- In dit menu zijn verwarming, ventilator en aandrijving uitgeschakeld.
- De operator kan hier met de **bedieningselementen (4)** alle instellingen uitvoeren die in de volgende hoofdstukken zijn beschreven.
- Is de temperatuur van het verwarmingselement bij het inschakelen echter groter dan 80°C, dan wisselt de display onmiddellijk naar de Cool Down-modus (hoofdstuk 1.8 Afkoelen), waarin de ventilator altijd met het volle vermogen loopt en zo het **lasmondstuk (9)** afkoelt. Vanuit deze modus kan door het indrukken van de e-Drive  op elk moment weer naar de functiemodus worden omgeschakeld.
- Wanneer de temperatuur van het verwarmingselement bij het afkoelen 60°C heeft bereikt, dan loopt de ventilator nog 2 minuten door en schakelt daarna automatisch uit. De **display (5)** springt naar de weergave van de instelwaarden terug (afb. 3).
- Door het verdraaien van de e-Drive  naar Profile kunnen de verschillende lasprofielen worden geselecteerd (afb. 4; hoofdstuk 1.7, Profielen selecteren).

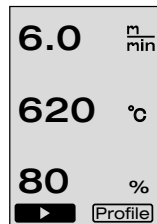

(afb. 3)



(afb. 4)

1.2 Toestandsweergave

- Door het indrukken van de e-Drive  worden verwarming en ventilator gestart, en de weergave van de instelwaarden wisselt naar de toestandsweergave.
- Bij het opwarmen van het **lasmondstuk (9)** wordt dit op de **display (5)** met progressiebalk, pijl ▲ (naar boven) en actuele waarde van de lastemperatuur (knipperend) weergegeven (afb. 5).
Is de instelwaarde voor de lastemperatuur bereikt, dan worden pijl en progressiebalk niet meer weergegeven (afb. 6).
- Licht de netspanning buiten (+/- 15%) de vereiste nom. spanning, dan wordt afwisselend het symbool met de gemeten onder- ⚡ / overspanning ⚡ en de ingestelde luchtstroom weergegeven. Is de luchtstroom 100 %, dan wordt het symbool knipperend met de gemeten onder- ⚡ / overspanning ⚡ weergegeven (afb. 7).
(alleen bij VARIANT T1 230 V~ mogelijk).

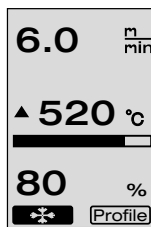

(afb. 5)

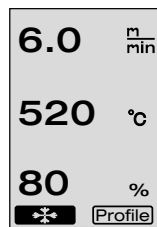

(afb. 6)

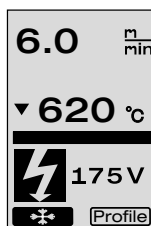

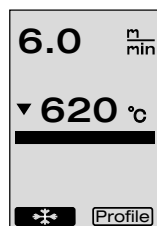

(afb. 7)



(afb. 8)



Onder-/overspanning kan het lasresultaat beïnvloeden!

- Wordt er na een vastgelegde tijd geen toets ingedrukt, en is het **lasmondstuk (9)** NIET in laspositie, dan wordt het standby-menu weergegeven (hoofdstuk 1.9, Standby).
- Bevindt het **lasmondstuk (9)** zich in de parkeerpositie, dan zijn de menu's Cool Down (hoofdstuk 1.8, Afkoelen) of Profielen (hoofdstuk 1.7, Profielen selecteren) door verdraaien van de e-Drive  selecteerbaar.
- Is het **lasmondstuk (9)** naar binnen gezwenkt, dan verdwijnen de beide menupunten  **Profile** van de **display (5)** en kunnen niet meer worden geselecteerd.
- Zolang het **lasmondstuk (9)** afkoelt wordt dit met een groeiende progressiebalk, pijl ▼ (naar omlaag) en een knipperende actuele waarde van de lastemperatuur op de **display (5)** weergegeven (afb. 8).

1. Functiemodus

1.3 Instellen van de aandrijfsnelheid

- Met de toets Aandrijving  kan de aandrijfsnelheid worden aangepast. Deze kan door verdraaien van de e-Drive  an 1.5 m/min. tot 18.0 m/min. in stappen van 0.1 m/min. worden ingesteld. Deze instelling kan bij in- of uitgeschakelde aandrijving worden uitgevoerd. Vindt er gedurende 3 seconden geen invoer met de **bedienings-elementen (4)** plaats, dan wordt de nieuwe aandrijfsnelheid geaccepteerd. Op de **display (5)** verschijnt de instelwaarde, of Cool Down (afb. 9).
- Bevindt het **lasmondstuk (9)** zich in laspositie, dan verschijnt het symbool (Start)  links onderaan op de **display (5)**.
- Door het indrukken van de e-Drive  kan de aandrijving worden ingeschakeld, het symbool (Stop)  verschijnt. De aandrijfsnelheid kan direct door verdraaien van de e-Drive  worden ingesteld.
- Door het opnieuw indrukken van de e-Drive  wordt het commando Stop uitgevoerd, de aandrijving wordt uitgeschakeld. Op de display verschijnt de instelwaarde of Cool Down.
- Wordt de toets Aandrijving  gedurende 3 seconden ingedrukt, dan springt de display naar een ander menu (zie hoofdstuk 1.6 Lengtemeting, Ventilator- en Aandrijvingscounter).
- Met de toets Verwarming  of de toets Ventilator  kan naar het betreffende menu worden gewisseld.

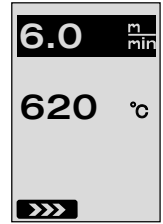

(afb. 9)

1.4 Instellen van de lasttemperatuur

- Met de toets Verwarming  kan de lasttemperatuur worden veranderd. De lasttemperatuur is door verdraaien van de e-Drive  instelbaar van 100°C tot 620°C in stappen van 10°C. De instelling wordt na 3 seconden geaccepteerd, tenzij binnen deze 3 seconden een andere toets werd ingedrukt (afb. 10).
- Wordt dit menu vanuit de weergave van de instelwaarden opgeroepen, dan kunnen verwarming en ventilator door indrukken van de e-Drive  worden gestart. Is de verwarming ingeschakeld, dan kan het menu Cool Down worden geselecteerd (hoofdstuk 1.8, Afkoelen) (afb. 11).
- Door de toets Verwarming  3 seconden lang in te drukken verschijnt de netspanning onder de aandrijfsnelheid. Deze oproep is alleen vanuit de toestandsweergave mogelijk (hoofdstuk 1.2). (alleen bij VARIANT T1 230 V~ mogelijk).
- Met de toets Aandrijving  of de toets Ventilator  kan naar het betreffende menu worden gewisseld.

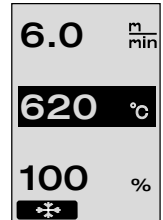

(afb. 10)

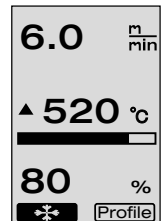

(afb. 11)

1. Functiemodus

1.5 Instellen van de luchtstroom

- Met de toets Ventilator  kan de luchtstroom worden veranderd. De luchtstroom is door verdraaien van de e-Drive  instelbaar van 40% tot 100% in stappen van 5%. De instelling wordt na 3 seconden geaccepteerd, tenzij binnen deze 3 seconden een andere toets werd ingedrukt. Is de luchtstroom op 100% ingesteld, dan verschijnt er geen weergave op de **display (5)** (afb 12).
- Wordt dit menu vanuit de weergave van de instelwaarden opgeroepen, dan kunnen de verwarming en de ventilator door het indrukken van de e-Drive  worden gestart.
- Het Cool Down-menu kan door het indrukken van de e-Drive  worden geselecteerd. (hoofdstuk 1.8, Afkoelen).
- Met de toets Aandrijving  of de toets Verwarming  kan naar het betreffende menu worden gewisseld.

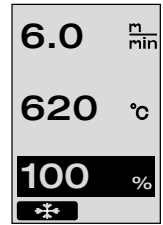

(afb. 12)

1.6 Lengtemeting, ventilator- en aandrijvingscounter

- Dit menu (afb. 13) verschijnt wanneer de toets Aandrijving  minstens 3 seconden lang wordt ingedrukt.
- Het menu geeft alle werkingstijden aan, evenals de afstand, die het apparaat sinds het inschakelen heeft afgelegd. De totale afstand (hier: 1034 m) kan niet worden veranderd en geeft de gehele afgelegde weg weer sinds de inbedrijfstelling.
- De dagafstand (hier: 012 m) wordt niet automatisch teruggezet, maar kan door de operator door **Reset** het indrukken van de e-drive  op nul worden teruggezet.
- De waarden bij Time betreffen de werkingstijden van de individuele componenten van het apparaat. Daarbij hebben de tijden betrekking op de ventilator «Blow» (hier: 043:58) en de aandrijving «Drive» (hier: 020:10). De tijd «Total» heeft betrekking op de algehele werkingstijd. Daarbij worden de uren en minuten (hier: 143:12) geteld, wanneer de **hoofdschakelaar (3)** is ingeschakeld.
- Wordt door het indrukken van de e-Drive  de pijl terug  geselecteerd, dan komt u naar het menu terug, van waaruit de toets Aandrijving  werd ingedrukt.

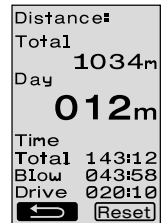



(afb. 13)

1. Functiemodus

1.7 Profielen selecteren

- Is de weergave **Profile** rechtsonder op de **display (5)** geactiveerd, dan kunnen door indrukken van de e-Drive  profielen worden geladen. Daarna verschijnt de tekst «Select Profile». Door verdraaien van de e-Drive  kan nu een profiel worden geselecteerd. De profielen FREE 1–7 kunnen door de operator zelf worden vastgelegd (zie hoofdstuk 2 Profile Setup). Alle andere profielen hebben vast toegewezen waarden en kunnen door de operator niet worden vastgelegd (afb 14).
- Door verdraaien van de e-Drive  kunnen de pijlen linksonder en rechtsonder op de **display (5)** worden geactiveerd.

Pijl naar rechts  door indrukken van de e-Drive  komt u naar de volgende pagina (afb 15).

Pijl naar links  door indrukken van de e-Drive  komt u naar de vorige pagina (afb 16).

- Wordt de pijl terug  door verdraaien van de e-Drive  geactiveerd, dan komt u door indrukken van de e-Drive naar  het menu terug, van waaruit het menu Profile werd geselecteerd (afb 15).

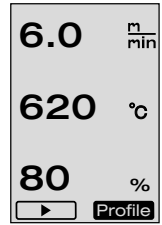

(afb. 14)

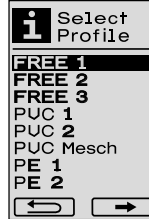

(afb. 15)

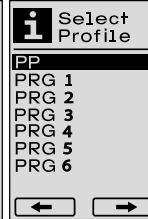

(afb. 16)



Testlas volgens lashandleiding van de materiaalfabrikant en volgens de nationale normen of richtlijnen uitvoeren. Testlas controleren.

1.8 Afkoelen

- Wordt het symbool  door indrukken van de e-Drive  geselecteerd (afb 17), dan verschijnt het menu «Cool down OK?» (afb 18). Door indrukken van de e-Drive  wordt het symbool OK rechtsonder op de **display (5)** geactiveerd. Daarmee wordt dan de afkoelprocedure gestart.
- Tijdens het afkoelen wordt de luchtstroom op 100% verhoogd en de actuele lasttemperatuur aangegeven (afb 19). Komt de lasttemperatuur beneden 60°C, dan loopt de ventilator 2 minuten door en wordt dan na afloop van deze tijd automatisch uitgeschakeld. De display wisselt naar de weergave van de instelwaarden.
- Wanneer tijdens de afkoelprocedure de e-Drive  wordt ingedrukt, wordt de verwarming gestart en op de **display (5)** verschijnt de toestandsweergave (zie hoofdstuk 1.2 Toestandsweergave).
- IIs het menu Cool Down actief, dan kan de aandrijving per hand met de toets Aandrijving  worden in-/ uitgeschakeld. De toetsen Verwarming  en Ventilator  hebben hier geen functie.

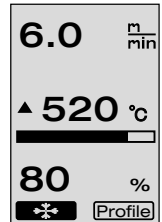

(afb. 17)



(afb. 18)

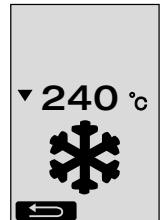

(afb. 19)

1. Functiemodus

1.9 Standby

- Is het **lasmondstuk (9)** niet in laspositie en vindt tijdens de door de operator vastgelegde standby-tijd geen invoer met de toetsen plaats, dan start de Cool Down-modus na afloop van de countdown (afb 20) automatisch. De afkoelprocedure wordt begonnen.
- Wordt vóór afloop van de countdown (180 seconden) de e-Drive  ingedrukt, dan wisselt de **display (5)** naar de toestandsweergave (zie hoofdstuk 1.2 Toestandsweergave).
- Instellen van de standby-tijd (hoofdstuk 2.3, Standby setup).

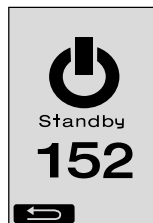

(afb. 20)

1.10 Storingmeldingen

- Wanneer er een storing bij de hetelucht-lasautomaat VARIANT T1 optreedt, verschijnt op de **display (5)** een melding die bovendien voorzien is van een error-code. Deze code maakt een precieze omschrijving van de storing mogelijk, zoals dat in de tabel hieronder te zien is.
- Bij storing 02 en storing 40 worden aparte symbolen weergegeven.
- Bij alle andere storingen wordt de steeksleutel weergegeven, als teken dat service nodig is.



Error	Type storing
Err00	Regelelektronica defect
Err01	Kabelbreuk of kortsluiting van de temperatuursonde
Err02	Verwarmingselement / elektronica defect (kabelbreuk in een/beide wikkeling(en))
Err04	Triac defect (één of beide Triacs zijn defect)
Err08	Ventilatormotor defect
Err40	Spanning 25% te laag (netspanning 75%) alleen VARIANT T1 230V~

2. Profile Setup





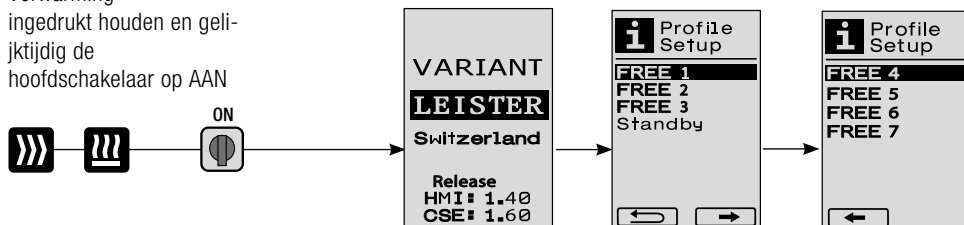





















2.1 Profile Setup toetscombinatie

Toetsen Aandrijving en Verwarming ingedrukt houden en gelijktijdig de hoofdschakelaar op AAN



2. Profile Setup

2.2 Profielen vastleggen

- Profile Setup kunnen 7 individuele profielen worden vastgelegd, waarbij de naam en alle drie parameters Aandrijving , Verwarming  en Ventilator  vrij kunnen worden ingesteld en dan door het indrukken van de e-Drive  kunnen worden opgeslagen (afb.21).
- De verschillende menupunten kunnen met de **bedieningselementen (4)** worden geselecteerd. Door het indrukken van de e-Drive  keert u terug naar de Profile Setup-selectie.
- Door verdraaien van de e-Drive  kunnen de pijlen linksonder en rechtsonder op de **display (5)** worden geactiveerd.
Pijl naar rechts  door indrukken van de e-Drive  komt u naar de volgende pagina (afb 15).
Pijl naar links  door indrukken van de e-Drive  komt u naar de vorige pagina (afb 16).
- Wordt het symbool  ABC door verdraaien van de e-Drive  geactiveerd, dan komt u door het indrukken van de e-Drive  naar het menu Profile Name (afb. 22).
- In het menu Profile Name kunnen door het verdraaien van de e-Drive  de tekens _ / . / A tot Z / 0 tot 9, evenals de pijlen naar links of rechts en de symbolen Save  of Back  worden geselecteerd.
- Profile Name veranderen
 - Door het verdraaien van de e-Drive  kunnen de pijlen naar links of rechts worden geselecteerd. Wordt de pijl naar rechts door indrukken van de e-Drive  geactiveerd, dan springt de cursor in de profielnaam één teken (zwart) naar rechts. Wordt de pijl naar links door indrukken van de e-Drive  geactiveerd, dan springt de cursor in de profielnaam één teken (zwart) naar links (afb 23).
 - Door verdraaien van de e-Drive  kan het gewenste teken (_ / . / A tot Z / 0 tot 9) worden geselecteerd. Door het indrukken van de e-Drive  wordt nu het in de profielnaam zwart weergegeven teken door het eerder geselecteerde teken vervangen.
- Profile Name opslaan of verwerpen
 - Wordt het symbool Save  door verdraaien van de e-Drive  geselecteerd, dan wordt de Profile Name door het indrukken van de e-Drive  opgeslagen.
 - Wordt het symbool Back  door verdraaien van de e-Drive  geselecteerd, dan wordt de Profile Name door indrukken van de e-Drive  verworpen (niet opgeslagen).

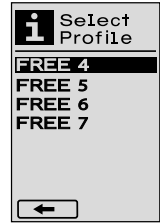

(afb. 21)

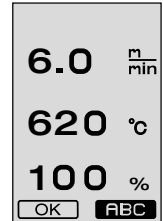

(afb. 22)



(afb. 23)



Testlas volgens lashandleiding van de materiaalfabrikant en volgens de nationale normen of richtlijnen uitvoeren. Testlas controleren.

2.3 Standby Setup

- Met de standby-tijd is de tijd vastgelegd die moet aflopen (geen toetsinvoer, **lasmondstuk (9)** niet in laspositie) tot de afkoelprocedure automatisch wordt geactiveerd (zie hoofdstuk 1.8 Afkoeling).
- Door verdraaien van de e-Drive  kan de tijd van 5 tot 120 minuten worden ingesteld. In de fabriek werd 40 minuten ingesteld.
- Door het indrukken van de e-Drive  keert u naar de Profile Setup-selectie terug.

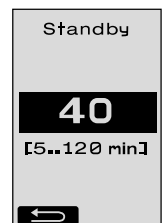

- Machine schakelt zich automatisch uit
 - Met de standby-functie wordt de machine na een ingestelde tijd automatisch uitgeschakeld (in de fabriek op 40 minuten ingesteld).
 - Indien gewenst standby-tijd verhogen (pagina 123, 2. Profile Setup, 2.3 Standby Setup).
- Kwaliteit van de las is gebrekkig
 - Aandrijfsnelheid, lastemperatuur en luchtstroom controleren
 - **Lasmondstuk (9)** met draadborstel reinigen
 - **Lasmondstuk (9)** is verkeerd ingesteld

Instelling van het lasmondstuk (9) als volgt uitvoeren

- HelveticaNeue MediumCond afkoelen (pagina 121, 1. Functiemodus, 1.8 Afkoelen)
- Inbusschroeven van de apparaathouder losdraaien
- Hoek van de **heteluchtventilator (8)** m.b.v. zwenkbewegingen instellen.
- Het **lasmondstuk (9)** moet (**pijl L**) op het **mondstukkaliber (34)** en (**pijl R**) op de onderlegger steunen.
- Inbusschroeven van de apparatenhouder vastdraaien
- Mondstukkaliber (34)** in positie brengen. Schaal op het **mondstukkaliber (34)** observeren
- Heteluchtventilator (8)** in laspositie brengen
- Instelschroeven zwenkas (25)** losdraaien
- Heteluchtventilator (8)** parallel aan **mondstukkaliber (34)** uitlijnen
- Instelschroeven zwenkas (25)** vastdraaien
- Mondstukkaliber (34)** verwijderen en testlas uitvoeren.

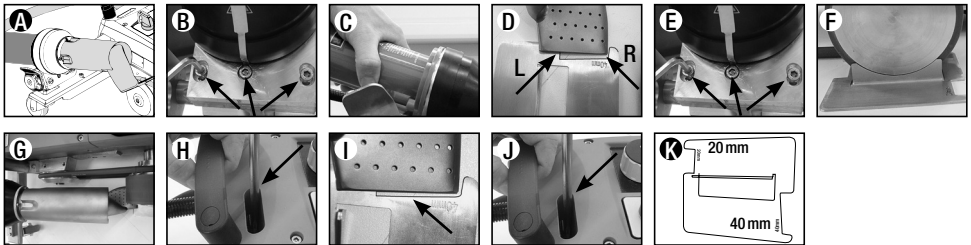

- Niet bereiken van de ingestelde temperatuur (display temperatuur knippert)
 - Netspanning controleren
 - Luchtstroom reduceren
 - Temperatuur reduceren
- Heteluchtventilator arrêteert niet in de laspositie
 - Kogeldrukstuk moet als volgt worden ingesteld:
 - **Lasmondstuk (9)** laten afkoelen (pagina 121, 1. Functiemodus, 1.8 Afkoelen)
 - **Lasmondstuk (9)** in laspositie brengen
 - Met een schroevendraaier **schroef (30)** licht vastrekken, daarna **schroef (30)** ca. 1/2 omwenteling terugdraaien.

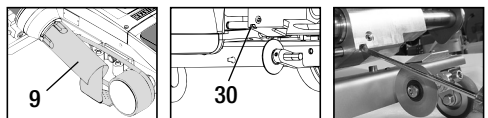

- Lasnaadbreedte is niet constant
 - Fijninstelling van de geleidingsrol als volgt uitvoeren:
 - **Lasmondstuk (9)** laten afkoelen (pagina 121, 1. Functiemodus, 1.8 Afkoelen)
 - **Lasmondstuk (9)** in laspositie brengen
 - Inbusschroef van de **geleidingsrol (15)** losdraaien
 - **Geleidingsrol (15)** in de gewenste positie schuiven
 - Inbusschroef vasttrekken
 - Testlas uitvoeren

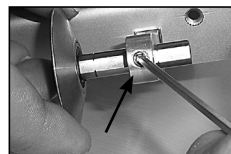
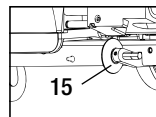
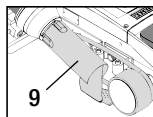

- Hetelucht-lasautomaat loopt van de naad weg (overlappingslassen)
 - Fijne spoorinstelling van de **stuurrol (14)** als volgt uitvoeren:
 - **Lasmondstuk (9)** laten afkoelen (pagina 121, 1. Functiemodus, 1.8 Afkoelen)
 - **Hoofdschakelaar (3)** uitschakelen 
 - Netsnoer van het lichtnet scheiden 
 - **Ballastgewicht (16)** verwijderen
 - Lasautomaat naar opzij kantelen
 - **Arrêteerschroef voor fijne spoorinstelling (31)** losdraaien en **hefboom voor fijne spoorinstelling (32)** naar de gewenste stand schuiven
 - **Arrêteerschroef voor fijne spoorinstelling (31)** vastdraaien
 - Hetelucht-lasautomaat in laspositie brengen
 - **Ballastgewicht (16)** aanbrengen
 - Hetelucht-lasautomaat weer in werking stellen
 - Testlas uitvoeren

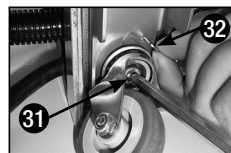
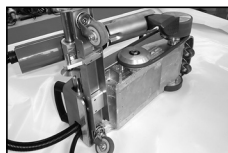
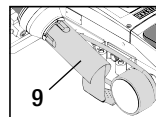
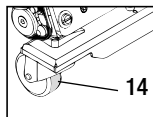



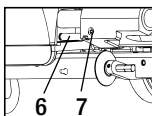
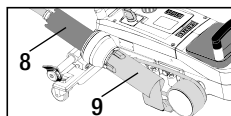
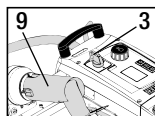

- Rolautomaat functioneert niet

Wanneer de aandrijfmotor niet automatisch na het intrekken van het **lasmondstuk (9)** start, is de **aanloopsensor (6)** eventueel verkeerd ingesteld.

 - **Aanloopsensor (6)** als volgt instellen:
 - **Lasmondstuk (9)** laten afkoelen (pagina 121, 1. Functiemodus, 1.8 Afkoelen)
 - **Hoofdschakelaar (3)** uitschakelen 
 - Met **heteluchtventilator (8)** het **lasmondstuk (9)** naar de laspositie verdraaien en vastklikken.
 - **Instelling van de aanloopsensor (6)** uitvoeren door met een inbussleutel de **schroefdraadpen (7)** te verdraaien; **BELANGRIJK: Schakelafstand 0.2 – 0.5 mm**
 - Functie controleren



Start de aandrijfmotor nog steeds niet automatisch, dan moet met onze service contact worden opgenomen.

	Overlapping	Zoom	Holle zoom (tot 70 mm)	Boordseisnoer	Voorgefabriceerd boordseis
 <p>Standaard- uitvoering</p>	●	●	●		
 <p>Zoom- / boord- seis-aanbouwstuk</p>		●	●	●	
 <p>Neerdrukker</p>		●		●	●
 <p>Boordseisgeleiding</p>				●	●

Toepassing

In plaats van de geleidingsrol (15) kan ook met het zoom- / boordseis-aanbouwstuk worden gewerkt.

Ook met standaard-uitvoering en fixatie van het dekzeil mogelijk.

Ook met standaard-uitvoering en fixatie van het dekzeil mogelijk.

Onderlegger met langsgroef voor boordseis wordt aanbevolen

Vouwvoze fixatie van het voorgefabriceerde boordseis.

Type

Goede fixatie van het dekzeil.

Markering van de zoomoverlapping verbetert de geleidingscontrole.

Markering van de zoomoverlapping verbetert de geleidingscontrole.

Markering van de zoomoverlapping verbetert de geleidingscontrole. Apparaat vrij laten lopen, geleiding van het dekzeil met boordseis per hand.

Uitvoeringen Leister VARIANT T1

Artikel no. 141.891 VARIANT T1, 230 V / 40 mm lasmondstuk / met Eurostekker

Artikel no. 141.892 VARIANT T1, 230 V / 20 mm lasmondstuk / met Eurostekker

Artikel no. 141.893 VARIANT T1, 400 V / 40 mm lasmondstuk / met CEE- stekker (3LNPE)

Artikel no. 141.894 VARIANT T1, 400 V / 20 mm lasmondstuk / met CEE- stekker (3LNPE)

Artikel no. 147.739 VARIANT T1, 200 V / 40 mm lasmondstuk / zonder stekker

Artikel no. 147.748 VARIANT T1, 200 V / 20 mm lasmondstuk / zonder stekker

Toebehoren

Om technische- en veiligheidsredenen mogen uitsluitend Leister-toebehoren worden gebruikt.

Artikel no. 142.650 Zoom- / boordselkit compleet

Artikel no. 139.438 Ballastgewicht

Artikel no. 140.530 Zoom-/ boordsel-aanbouwstuk

Artikel no. 137.843 T-greep geleidingsstaaf bovendeele

Artikel no. 142.221 Neerdrucker

Artikel no. 116.798 Messing draadborstel

Artikel no. 141.326 Boordselgeleiding

Artikel no. 142.705 Apparatenkoffer

Bijscholing

- Leister Technologies AG en de aangesloten geautoriseerde servicepunten bieden kostenloze lascursussen en bijscholing aan. Voor informatie zie www.leister.com.

Onderhoud

- De luchtinlaat bij de **heteluchtventilator (8)** moet bij vervuiling met een penseel worden gereinigd
- **Lasmondstuk (9)** met messing draadborstel reinigen
- Controleer het **netsnoer (1)** en de stekkers op elektrische en mechanische beschadigingen

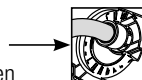

Service en reparatie

- Wanneer de aandrijvingscounter 400h, of de ventilatorcounter 2000h heeft bereikt, dan verschijnt bij het volgende inschakelen van de **hoofdschakelaar (3)** op de **display (5)** de melding «Maintenance servicing». Deze melding wordt 10 seconden getoond en kan niet door de **bedieningselementen (4)** worden weggeklikt.
- Reparaties mogen uitsluitend door daarvoor geautoriseerde **Leister-Servicepunten** worden uitgevoerd. Die waarborgen **binnen 24 uur** een vakkundige en betrouwbare **reparatieservice** met originele reserveonderdelen volgens de schakelschema's en reserveonderdeellijsten.

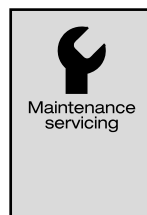

Garantie

- Voor dit apparaat gelden de door de directe salespartner/verkoper verleende garantie of de aanspraak op garantie vanaf de datum van aankoop. Bij een garantie of aanspraak op garantie (bewezen door de factuur of leveringsbewijs) de worden productie- of verwerkingfouten hersteld door de salespartner door middel van levering van vervangende onderdelen of reparatie. Verwarmingselementen zijn uitgesloten van de garantie of aanspraak op garantie.
- Verdere garantie of aanspraken op garantie worden in het kader van het dwingende recht uitgesloten.
- Schade als gevolg van normale slijtage, overbelasting of onachtzaam gebruik, is van de garantie uitgesloten.
- Geen garantie of aanspraak op garantie wordt verleend bij apparaten die door de koper zijn omgebouwd of veranderd.

Tillykke med dit køb af en varmluftssvejsesmaskine VARIANT T1

Du har valgt en førsteklasses varmluftssvejsesmaskine fremstillet af materialer af høj kvalitet. Denne enhed er udviklet og fremstillet i overensstemmelse med de nyeste svejseteknologier. Hver VARIANT T1 gennemgår strenge kvalitetskontroller, før den forlader fabrikken i Schweiz.

Indholdsfortegnelse

Anvendelse, advarsel, forsigtighed	Side	129
Overensstemmelse, bortskaffelse, tekniske data	Side	130
Beskrivelse af enheden, betjeningsølemeter	Side	131
Info-ikoner, aktive ikoner, hurtig info	Side	132
Driftsmæssig tilgængelighed, placering af enhed	Side	133
Svejsesarbejdsgang	Side	134
Transportparathed, knapkombinationer	Side	135
Arbejdstilstand (afsnit 1)		
1.1 Display med indstillingspunkt-værdi		
1.2 Arbejdsdisplay	Side	136
1.3 Indstilling af drevhastigheden		
1.4 Indstilling af svejsetemperatur	Side	137
1.5 Indstilling af luftvolumen		
1.6 Længdemåling, blæser og omgangstæller	Side	138
1.7 Valg af profiler		
1.8 Afkøling	Side	139
1.9 Standby		
1.10 Fejlmeddelelser		
Profilopsætning (afsnit 2)		
2.1 Profilopsætning knapkombination	Side	140
2.2 Oprettelse af profiler		
2.3 Opsætning af standby	Side	141
OFTE STILLEDE SPØRGSMÅL	Side	142/143
Svejsenanvendelser	Side	144
Versioner, tilbehør, uddannelse, vedligeholdelse, service og reparation, garanti	Side	145



Læs betjeningsvejledningen omhyggeligt, før du starter enheden, og gem den til senere brug.

Leister VARIANT T1 Varmluftssejsemaskine

Anvendelse

Enheden bør kun anvendes i rum med god udluftning. Hvis det er nødvendigt, skal arbejdet udføres med en ventilator eller personligt beskyttelsesudstyr. Sørg for, at materialet ikke brænder under svejsningen. Forhør dig hos materialeproducenten angående sundhedsfarlige tilsætningsstoffer. De lovmæssige bestemmelser vedrørende sundhedsbeskyttelse i det pågældende land skal finde anvendelse.

- Håndholdt varmluftssvejsmaskine til overlappning, kant- og rørsvejsning af presenningmateriale (PVC og lignende materialer).
- Må kun bearbejdes i godt ventilerede rum



Advarsel



Dødsfare ved åbning af enheden, da strømførende dele og forbindelser er blottede. Tag stikket ud af stikkontakten, inden enheden åbnes.



Risiko for brand og eksplosion, hvis varmeluftssvejsningsenheder bruges forkert, især i nærheden af brændbare materialer og eksplosive gasser.



Fare – kan forårsage forbrændinger! Rør ikke ved svejsedysen, når den er varm. Lad enheden køle af.
Ret ikke varmluftsstrømmen mod mennesker eller dyr.



Tilslut enheden til **stikkontakt med beskyttende jordledning**. Enhver afbrydelse af den beskyttende jordledning inden i eller uden for enheden er farlig.
Brug kun forlængerledninger med beskyttelsesjordledning!



Forsigtig



Den nominelle spænding, der er angivet på enheden, skal svare til netspændingen. N 61000-3-11; $Z_{maks.} = 0,164 \Omega + j 0,102 \Omega$. Kontakt om nødvendigt forsyningselskabet.
Flyt varmluftblæseren ud ved **strømsvigt**.



Når enheden bruges på byggepladser, er en **fejlstømsafbryder** essentiel for sikkerheden for dem, der er der.



Enheden **må ikke efterlades uden opsyn**, når den er i brug. Varme kan nå brændbare materialer, som er ude af syne.

Enheden må kun betjenes af **uddannet personale** eller under deres opsyn. Børn må under ingen omstændigheder bruge enheden.



Skal holdes **væk fra våde og fugtige områder**.



Enheden må ikke løftes med yderligere vægt.

Overensstemmelse

Leister Technologies AG, Galileo-Strasse 10, CH-6056 Kaegiswil/Schweiz bekræfter, at dette produkt i den version, der er sat i omløb af os, opfylder kravene i følgende EU-direktiver.

Direktiver: 2006/42/EF, 2014/30/EU, 2011/65/EU
Harmoniserede standarder: EN ISO 12100, EN 55014-1, EN 55014-2, EN 61000-3-2, EN 61000-3-3, EN 61000-3-11 (Z_{max}), EN 61000-6-2, EN 62233, EN 60335-1, EN 60335-2-45, EN IEC 63000

Kaegiswil, 05/11/2020

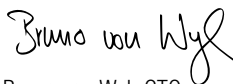

Bruno von Wyl, CTO





Christoph Baumgartner, GM

Bortskaffelse



Elektrisk udstyr, tilbehør og emballage skal genbruges på en miljøvenlig måde. Bortskaf ikke elektrisk udstyr sammen med husholdningsaffald!

Tekniske data

Spænding	V~	200	230	400 (2 LNPE)	V~	200	230	400 (2 LNPE)
Strømforbrug	W	4200	3680	5700	W	4200	3680	5700
frekvens	Hz	50/60			Hz	50/60		
Temperatur	°C	100 – 620 trinløs			°F	212 – 1148 trinløst		
drev	m/min.	1,5 – 18 trinløst			ft/min	4,9 – 59,1 trinløst		
luftvolumen	%	40 – 100			%	40 – 100		
Emissionsniveau	L _{pA} (dB)	70			L _{pA} (dB)	70		
Vægt	kg	22			pund	48,5		
uden strømforsyningskabel								
Mål L × B × H	mm	500 × 400 × 195			tommer	19,7 × 15,8 × 7,7		
Overensstemmelsesmærke		CE				CE		
Beskyttelsesklasse I								

Tilslutningsspændingen kan ikke ændres

Vi forbeholder os retten til at foretage tekniske ændringer

Info-ikoner

Følgende ikoner vises på displayet til information.



Nedkøling af svejседyse



Enhed i Standby-tilstand, enheden slukkes efter et stykke tid



Kontakt et autoriseret servicecenter



Angiver, at temperaturen stiger



Angiver, at temperaturen falder



Fremskridtslinje

Aktive ikoner

Følgende ikoner vises på displayet og aktiveres ved at trykke på e-Drive .



Tænd for opvarmning og blæser (hvis blæseren endnu ikke kører)



Stop drevet



Start drevet



Automatisk afkøling (varme fra, blæser til)



Opad i strukturen (tilbage til det forrige program)



Enter, bekræft



Vælg profil



Gem ændret navn



Skift profilnavn



Til næste skærmbillede



Til næste skærmbillede



Nulstil daglig afstand





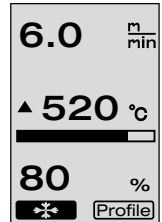
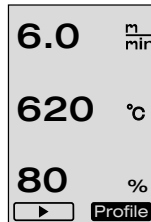
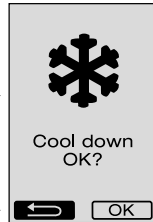









Info-ikoner

Aktive ikoner





Hurtige oplysninger

Hvordan starter jeg varmluftssvejsmaskinen VARIANT T1?

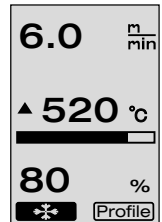
1. Opret nettilslutning til elnettet 
2. Hovedafbryder (3) TIL 
3. Tryk på drev-knappen  → **6.0**  Drej e-Drive 
4. Tryk på opvarmningsknappen  → **620**  Drej e-Drive 
5. Tryk på blæserknappen  → **100**  Drej e-Drive 
6. Tryk på e-Drive  Opvarmningstid ca. 1-2 minutter → 
7. Udfør en testsvejsning i henhold til materialeproducentens svejsevejledning og nationale standarder eller direktiver. Kontrollér svejsetest.
8. Svejsning 



Sådan tændes/slukkes varmluftssvejsmaskinen VARIANT T1

1. Tryk på e-Drive  (fig. 1).
2. Tryk på «Afkøl OK» e-Drive,  og lad det køle af i ca. 4 minutter (fig. 2) Blæseren slukkes automatisk.
3. Når svejседysen (9) er kølet af, SLUKKES hovedafbryderen (3) FRA 

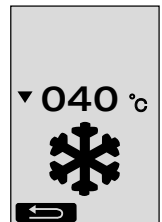

(Fig. 1)

(Fig. 2)

Driftsmæssig tilgængelighed

- Inden ibrugtagning skal **strømkablet (1)** og stikket samt forlængerkablet kontrolleres for elektriske og mekaniske skader.
- Standardindstillingen for **svejsedysen (9)** udføres på fabrikken.
- Kontrollér standardindstillingen for **svejsedysen (9)**.
 - Kontrollen kan foretages ved hjælp af **dysemåleren (34)** eller svarende til Detalje A og B.

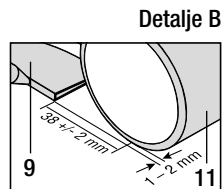
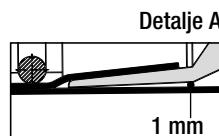
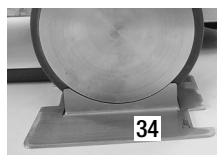

- Monter **styrebjælken** med **cylinderskruehoveder (18)**.
 - Flyt **styrebjælkens bund (19)** til den ønskede position ved hjælp af **skruerhåndtaget (24)** og **styrebjælkens top (20)** ved hjælp af **fastspændingsgrebet (21)**.
 - Hæng trækafastningen på **strømforsyningsledningen (1)** ind i **holderen (22)** på styrebjælken eller på slæden.
- Indsæt **yderligere vægt (16)** (maks. to yderligere vægte).

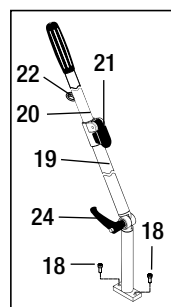
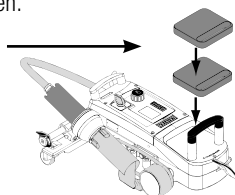

Tilslut enheden til nominel spænding. Den nominelle spænding, der er angivet på enheden, skal svare til netspændingen.

Flyt **varmluftblæseren (8)** ud til parkeret position, hvis **netstrømmen svigter**.

Placering af enhed

- Presenningmaterialet skal være rent mellem overlappningen og på den øvre og nedre side.
- **Svejsedysen (9)**, **trykrullen (11)**, **aflederrullen (12)**, **rundrem (23)** og **holdeenheden (13)** skal være rene. Hvis varmluftssvejsemaskinen ikke er klar til transport, løftes enheden op ved hjælp af løfteenhedens **håndtag (27)**. **Transportrullerne (26)** fungerer nu.
- Flyt varmluftssvejsemaskinen til svejseposition.
- Sænk varmluftssvejsemaskinen til svejsepositionen med **håndtaget (27)**. **Transportrullerne (26)** fungerer ikke længere og er således aflastet.
- Drej **styrerullen (15)** nedad.
- **Styrerullen (15)** skal være parallel med **trykrullen (11)** (Detalje C).

Håndtag til transportparathed til venstre

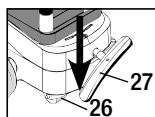

Håndtag til svejseposition til højre

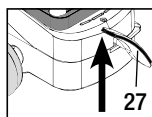

Detalje C

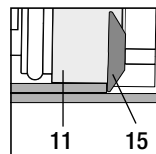

Arbejdsgang for svejsning

• Klargøring



Udfør en testsvejsning i henhold til materialeproducentens svejsningsvejledning og nationale standarder eller retningslinjer. Kontrollér svejsetest.

- Indstil svejseparametre for drev, opvarmning og blæser (se afsnit 1, Arbejdstilstand).
- Svejsetemperaturen skal være nået (opvarmningstid ca. 1-2 min.).

• Begynd at svejse





- Drej **styrerullen (15)** nedad.
- Drej **varmluftblæseren (8)** forsigtigt åben og ind, indtil **låseknasten (10)** er skubbet ud af fordybningen. Sænk straks **varmluftblæseren (8)**.



ADVARSEL: Hvis **varmluftblæseren (8)** skubbes for langt ind, vil **svejsedyesen (9)** og **trykrollen (11)** røre hinanden. Så kan **Varmluftblæseren (8)** ikke sænkes.

- Løft det øvre presenningmateriale en smule i styrerulleområdet, og flyt **svejsedyesen (9)** mellem de overlappende presenninger så langt som muligt ved at skubbe til **varmluftblæseren (8)**.



- Drevmotoren starter automatisk. Ingen automatisk start (afsnit OSS, side 143).
- Maskinen kan startes manuelt med **betjeningsenhederne (4)** Drev  og e-Drive .
- Hvis drevet startes via  og e-Drive,  og **svejsedyesen (9)** derefter skubbes ind, vil varmluftsvejsemaskinen fortsætte med at fungere i ca. 30 cm, efter at **svejsedyesen (9)** er drejet ud (forsinket deaktivering af drev).
- Varmluftsvejsemaskinen kan styres langs overlapningen ved **styrebjælkehåndtaget (33)**, **bærehåndtaget (17)** eller **holdehåndtaget (28)**. Styr varmluftsvejsemaskinen uden tryk på **styrebjælkehåndtaget (33)**, **bærehåndtaget (17)** eller **holdehåndtaget (28)** under svejsningen. Tryk kan føre til svejsefejl. Hold øje med **styrerullens (15) position**.

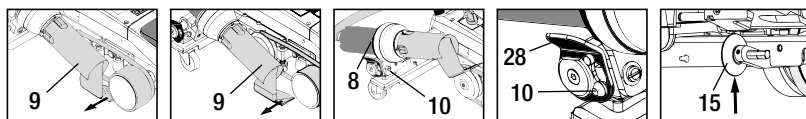

• Efter svejsning

- Efter svejsning skubbes **svejsedyesen (9)** ud fra svejsepositionen til højre ved hjælp af **varmluftblæseren (8)** og hæves.
- Skub **varmluftblæseren (8)** til højre, indtil **låseknasten (10)** låses fast i fordybningen i **holdehåndtaget (28)**. **Varmluftblæseren (8)** er i parkeret position.
- Drej **styrerullen (15)** opad.

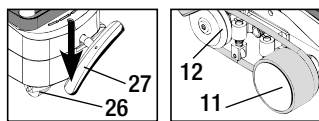

- Sænk **transportrullerne (26)** ved at dreje **håndtaget (27)**. **Trykrollen (11)** og **aflederrullen (12)** aflastes til transport på denne måde.



- Når svejsearbejdet er færdigt, skal du ved hjælp af e-Drive  (tryk to gange) slukke for opvarmningen. Dette afkøler **svejsedyesen (9)**, og blæseren slukkes automatisk efter ca. 4 minutter (afsnit 1.8, Afkøling).
- Sluk for **hovedafbryderen (3)** .



Tag strømforsyningskablet ud af strømforsyningen.

- Rengør **svejsedyesen (9)** med en messingbørste.

Transportparathed

- Drej **styrerullen (15)** opad.
- Skub **varmluftblæseren (8)** til højre, indtil **låseknasten (10)** låses fast i fordybningen i **holdehåndtaget (28)**. **Varmluftblæseren (8)** er i parkeret position.
- Sænk **transportrullerne (26)** ved at dreje **håndtaget (27)**. Trykrullen (11) og aflederrullen (12) aflastes til transport på denne måde.

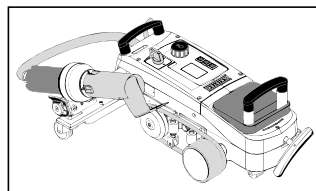
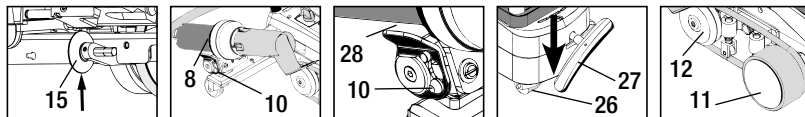

Flytte



Bære

Knapkombinationer

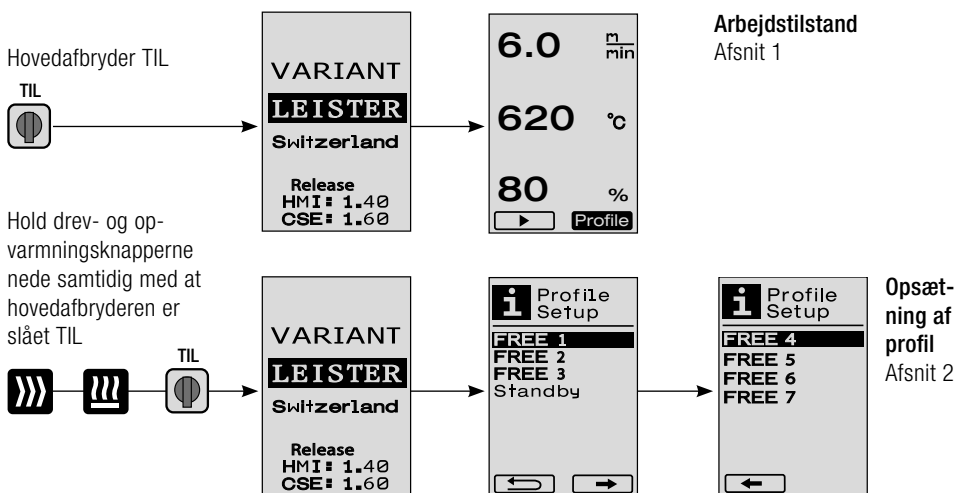

1. Arbejdstilstand

1.1 Visning af indstillingspunktværdi (efter tænding af enheden)

Hovedafbryder (3) TIL 

- Når der tændes for enheden, vises de sidste indstillede værdier på **displayet (5)** (fig. 3).
- Varmeelementet, blæseren og drevet slukkes i denne menu.
- Her kan brugeren udføre alle de indstillinger, der er beskrevet i de efterfølgende afsnit, ved hjælp af **betjeningsknapperne (4)**.

- Hvis varmelegemetens temperatur imidlertid er højere end 80 °C, når det tændes, skifter displayet straks til afkølingstilstand (afsnit 1.8 Afkøling), hvor blæseren altid kører med fuld kraft, hvorved

svejsedyesen (9) køles ned. Du kan når som helst skifte tilbage til arbejdstilstanden fra denne tilstand ved at trykke på e-Drive .

- Hvis varmelegemetens temperatur når 60 °C under afkøling, fortsætter blæseren med at være i drift i 2 minutter og slukker derefter automatisk. Displayet (5) skifter tilbage til Indstillingspunktværdi (fig. 3).
- Ved at dreje e-Drive  til Profiler kan man vælge forskellige svejseprofiler (fig. 4; afsnit 1.7 Valg af profiler).

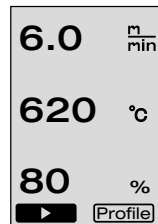







(Fig. 3)



(Fig. 4)

1.2 Arbejdsdisplay

- Ved at trykke på e-Drive  startes opvarmningen, og displayets indstillingspunktværdi ændres til arbejdsdisplayet.
- Når **svejsedyesen (9)** varmer op, vises dette på **displayet (5)** med en statuslinje, en pil  (op) og den faktiske værdi af svejsetemperaturen (blinkende) (fig. 5). Når svejsetemperaturens indstillingspunktværdi er nået, vises pilen og statuslinjen ikke længere (fig. 6).
- Hvis netspændingen er udenfor (+/- 15 %) den specificerede nominelle spænding, vises symbolet skiftevis med den målte underspænding /overspænding  og den indstillede luftmængde. Hvis luftvolumen er 100 %, vil symbolet blinke med den målte underspænding /overspænding  (fig. 7). (Kun muligt med VARIANT T1 230 V~).

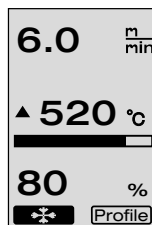

(Fig. 5)

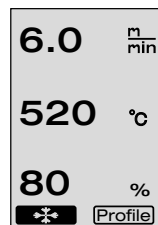

(Fig. 6)

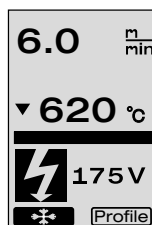

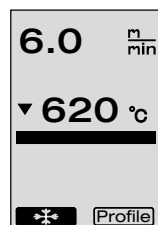

(Fig. 7)



(Fig. 8)



Underspænding/overspænding kan påvirke svejseresultaterne!

- Hvis der ikke trykkes på en knap efter et bestemt tidsrum (**svejsedyse (9) IKKE** i svejseposition), vises Standby-menuen (afsnit 1.9 Standby).
- Hvis **svejsedyesen (9)** er i parkeret position, kan menuerne Afkøling (afsnit 1.8 Afkøling) eller Profiler (afsnit 1.7 Valg af profiler) vælges ved at dreje e-Drive .
- Hvis **svejsedyesen (9)** drejes ind,  vil de to menuer forsvinde på **displayet (5)** og kan ikke længere vælges.
- Mens **svejsedyesen (9)** køler ned, vises dette med en udfyldt statuslinje, pil  (ned) og blinkende med svejsetemperaturens faktiske værdi på **displayet (5)** (fig. 8).

1. Arbejdstilstand

1.3 Indstilling af drevhastigheden

- Drevhastigheden kan tilpasses med drevknappen . Dette kan indstilles ved at dreje e-Drive i trin på 0,1 m/min. fra 1,5 m/min. til 18,0 m/min. Denne indstilling kan udføres med drevet tændt eller slukket. Hvis der ikke indtastes noget med **betjeningselementerne (4)** inden for 3 sekunder, accepteres den nye drevhastighed. Displayet Indstillingspunktværdi eller menuen Afkøling vises på **displayet (5)** (fig. 9).
- Hvis **svjesedyseren (9)** ikke er i svejsepositionen, vises symbolet (Start) nederst til venstre på **displayet (5)**.
- Drevet kan tændes ved at trykke på e-Drive, hvorefter (Stop) vises. Kørehastigheden kan justeres direkte ved at dreje e-Drive .
- Ved at trykke på e-Drive igen, udføres kommandoen Stop, hvilket slukker for drevet. Displayet Indstillingspunktværdi eller menuen Afkøling vises på displayet.
- Hvis der trykkes på knappen e-Drive i 3 sekunder, skifter displayet til en anden menu (se afsnit 1.6 Længdemåling, blæser og drevtæller).
- Du kan skifte til den relevante menu ved at trykke på knappen Opvarmning eller Blæser .

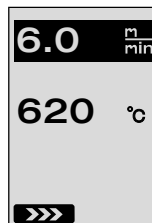

(Fig. 9)

1.4 Indstilling af svejsetemperatur

- Svejsetemperaturen kan ændres med knappen Opvarmning . Svejsetemperaturen kan indstilles i trin på 10 °C fra 100 °C til 620 °C ved at dreje på e-Drive . Indstillingen accepteres efter 3 sekunder, så længe der ikke trykkes på en knap inden for disse 3 sekunder (fig. 10).
- Hvis denne menu kaldes frem fra displayet Indstillingspunktværdi, kan opvarmningen og blæseren startes ved at trykke på e-Drive . Når opvarmningen er tændt, kan menuen Afkøling vælges (afsnit 1.8 Afkøling) (fig. 11).
- Hvis der trykkes på knappen Opvarmning i 3 sekunder, vises netspændingen under drevhastigheden. Dette opkald er kun muligt fra arbejdsdisplayet (afsnit 1.2). (Kun muligt med VARIANT T1 230 V~).
- Du kan skifte til den relevante menu ved at trykke på knappen Drev eller Blæser .



(Fig. 10)

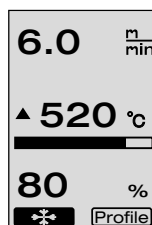

(Fig. 11)

1. Arbejdstilstand



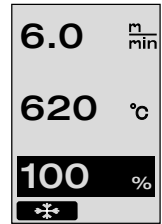

1.5 Indstilling af luftvolumen

- Luftvolumenen kan ændres med knappen Blæser . Luftvolumenen kan indstilles i trin på 5 % fra 40 % til 100 % ved at dreje e-Drive . Indstillingen accepteres efter 3 sekunder, så længe der ikke trykkes på en knap inden for disse 3 sekunder. Hvis luftvolumen er indstillet til 100 %, vises der ingen oplysninger på **displayet (5)** (fig. 12).
- Hvis denne menu kaldes frem fra displayet Indstillingspunkt-værdi, kan opvarmningen og blæseren startes ved at trykke på e-Drive .
- Afkølingsmenuen kan vælges ved at trykke på e-Drive  (Afsnit 1.8 Afkøling).
- Du kan skifte til den relevante menu ved hjælp af knappen Drev  eller Blæser .



(Fig. 12)

1.6 Længdemåling, blæser og drevtæller



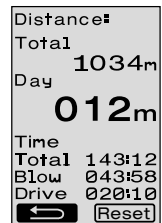





- Denne menu (fig. 13) vises, hvis der trykkes på knappen Drev  i mindst 3 sekunder.
- Menuen viser alle driftstider og afstanden, som enheden har kørt, siden den blev tændt. Den samlede afstand (her: 1034 m) kan ikke ændres og viser hele stien, der er taget, siden den blev sat i drift.
- Den daglige afstand (her: 012 m) nulstilles ikke automatisk, men kan i stedet nulstilles af brugeren **Reset** ved at trykke på e-Drive .
- Tidsværdierne vedrører driftstiden for enhedens individuelle komponenter. Tiden er indstillet til blæseren "Blow" (her: 043:58) og drevet "Drive" (her: 020:10). Den "samlede" tid henviser til driftstiden. Den tæller de timer og minutter (her: 143:12), hvor **hovedafbryderen (3)** er tændt.
- Hvis pilen Tilbage  vælges ved at trykke på e-Drive , vil du blive ført tilbage til den menu, hvorfra der er trykket på knappen Drev .



(Fig. 13)

1. Arbejdstilstand

1.7 Valg af profiler

- Hvis displayet **Profile** nederst til højre på **displayet (5)** er aktiveret, kan profiler indlæses ved at trykke på e-Drive . Displayet "Vælg profil" vises. En profil kan vælges ved at dreje e-Drive . Profilerne FRI 1-7 og 3 kan defineres af brugerne selv (se afsnit 2 Profilsætning). Alle andre profiler har permanent tildelte værdier og kan ikke defineres af brugeren (fig. 14).
- Når e-Drive  drejes, aktiveres venstre- eller højrepilene på **displayet (5)** i bunden.
Højre pil  ved at trykke på e-Drive  til næste side (fig. 15).
Venstre pil  ved at trykke på e-Drive  til forrige side (fig. 16).
- Hvis pilen Tilbage  aktiveres ved at dreje e-Drive , føres du tilbage til den menu, som menuen Profiler er valgt fra, ved at trykke på e-Drive  (fig. 15).

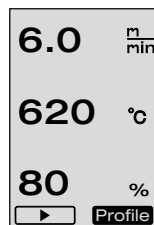

(Fig. 14)

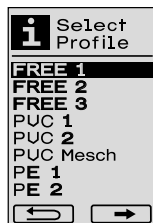

(Fig. 15)

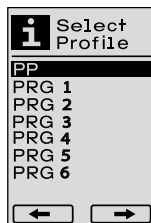

(Fig. 16)

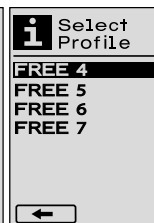

Udfør en testsvejsning i henhold til materialeproducentens svejsningsvejledning og nationale standarder eller retningslinjer. Kontrollér svejsetest.

1.8 Afkøling

- Hvis symbolet  vælges ved at trykke på e-Drive  (fig. 17), vises menuen "Afkøling, OK?" (fig. 18). Ved tryk på e-Drive  aktiveres symbolet OK nederst til højre på **displayet (5)**. Dette starter afkølingsprocessen.
- Under afkølingsprocessen øges luftvolumen til 100 %, og denøjeblikkelige svejsetemperatur vises (fig. 19). Hvis svejsetemperaturen på 60 °C er faldet under, vil blæseren fortsætte med at køre i 2 minutter og automatisk slukke, når denne tid udløber. Displayet skifter til visning af indstillingspunkt værdi.
- Hvis der trykkes på e-Drive  under afkølingsprocessen, starter opvarmningen, og arbejdsdisplayet vises på **displayet (5)** (se afsnit 1.2 Arbejdsdisplay).
- Hvis afkølingsmenuen er aktiv, kan drevet tændes/slukkes manuelt via knappen Drev . Knapperne Opvarmning  og Blæser  har ingen funktion.

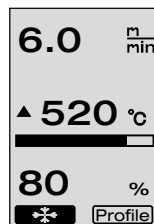

(Fig. 17)



(Fig. 18)



(Fig. 19)

1. Arbejdstilstand

1.9 Standby

- Hvis **svejsedyseren (9)** ikke er i svejsepositionen, og der ikke trykkes på nogen knap i en standbytid, der er defineret af brugeren, starter afkølingstilstanden automatisk, når nedtællingen er færdig (fig. 20). Afkølingsprocessen påbegyndes.
- Hvis der trykkes på e-Drive , før nedtællingen er færdig (180 sekunder), skifter **displayet (5)** til arbejdsdisplay (se afsnit 1.2 Arbejdsdisplay).
- Indstilling af standbytid (afsnit 2.3 Indstilling af standby).

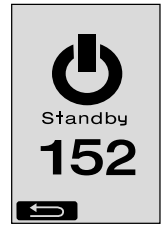

(Fig. 20)

1.10 Fejlmeddelelser

- Hvis der opstår en fejl i varmluftsvejsemaskinen VARIANT T1, vises der en meddelelse med en fejlkode på **displayet (5)**. Denne kode står for en mere præcis definition af fejlen, som kan ses på listen nedenfor.
- Separate symboler vises for fejl 02 og fejl 40.
- I tilfælde af alle andre fejl vises skruenøglen til serviceprompten.



Fejl	Fejltype
Err00	Betjeningselektronikken er defekt
Err01	Afbrydelse eller kortslutning af temperatursonden
Err02	Varmelegeme/elektronik defekt (afbrydelse i en/begge viklinger)
Err04	Defekt Triac (en eller begge Triac'er er defekte)
Err08	Blæsemotor defekt
Err40	Underspænding 25 % (netspænding 75 %) kun VARIANT T1 230 V~

2. Opsætning af profil

2.1 Knapkombination til profilopsætning

Hold drev- og opvarmningsknapperne nede samtidig med at hovedafbryderen slået TIL.













2. Opsætning af profil

2.2 Oprettelse af profiler

- Med Profilsætningen kan du oprette 7 individuelle profiler, hvor fra navnet og alle tre parametre Drev , Opvarmning , Blæser  kan indstilles frit og derefter gemmes ved at trykke på e-Drive  (fig. 21).
- De forskellige menupunkter kan vælges ved hjælp af **betjeningssele-menterne (4)**. Hvis du trykker på e-Drive , vender du tilbage til profilsætningsvalget.
- Når e-Drive  drejes, aktiveres venstre- eller højrepilene på **displayet (5)** i bunden. Højre pil  ved at trykke på e-Drive  til næste side (fig. 15). Venstre pil  ved at trykke på e-Drive  til forrige side (fig. 16).
- Hvis ABC-symbolet  aktiveres ved at dreje e-Drive , bliver du ført tilbage til menuen Profilnavn ved at trykke på e-Drive  (fig. 22).
- I menuen Profilnavn kan du dreje e-Drive  for at vælge tegnene **_ / . / A til Z / 0 til 9**, samt venstre eller højre pile og symbolerne Gem  eller Tilbage .

• Ændre profilnavn

- Hvis du drejer e-Drive , kan du vælge venstre- eller højrepilene. Hvis den højre pil vælges ved at trykke på e-Drive , springer positionen i profilnavnet et tegn (sort) til højre. Hvis du aktiverer den venstre pil ved at trykke på e-Drive , springer positionen i profilnavnet et tegn (sort) til venstre (Fig. 23).
- Ved at dreje e-Drive  er det muligt at vælge det ønskede tegn (**_ / . / A til Z / 0 til 9**). Hvis du trykker på e-Drive , erstattes det tegn, der er vist som sort i profilnavnet, nu med det tidligere valgte tegn.
- Gem eller afvis profilnavn
 - Hvis Gem-symbolet  vælges ved at dreje e-Drive , bliver profilnavnet blive gemt ved at trykke på e-Drive .
 - Hvis Tilbage-symbolet  vælges ved at dreje e-Drive , vil profilnavnet blive afvist (ikke gemt) ved tryk på e-Drive .

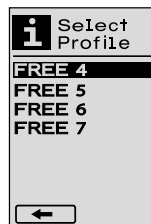

(Fig. 21)

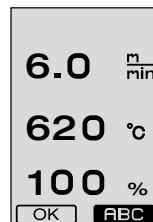

(Fig. 22)





(Fig. 23)



Udfør en testsvejsning i henhold til materialeproducentens svejsningsvejledning og nationale standarder eller direktiver. Kontrollér svejsetest.

2.3 Opsætning af standby

- Standbytiderne definerer den tid, der skal gå (ingen knapper trykket ned, **svejsedyse (9)** ikke i svejseposition), før afkølingsprocessen (se afsnit 1.8 Afkøling) udløses automatisk.
- Ved at dreje e-Drive  kan tiden indstilles fra 5 til 120 minutter. 40 minutter er indstillet fra fabrikken.
- Hvis du trykker på e-Drive , vender du tilbage til Profilsætning.



- Maskinen slukker automatisk
 - Maskinen slukkes automatisk efter en indstillet tid med Standby-tilstand (fabriksindstilling 40 minutter). Øg om nødvendigt standby-tiden (side 141, 2. Profilopsætning, 2.3 Standbyopsætning).
- Svejsekvaliteten er mangelfuld
 - Kontrollér drevhastighed, svejsetemperatur og luftmængde
 - Rengør **svejsedyser (9)** med en stålbørste
 - **Svejsedyser (9)** er indstillet forkert

Udfør justeringen af svejsedyser (9) på følgende måde

- Lad **svejsedyser (9)** køle af (side 139, 1. Arbejdstilstand, 1.8 Afkøling).
- Løsn sekskantskruerne på enhedsholderen.
- Udfør vinkeljustering ved hjælp af drejebævælgelser ved **varmluftblæseren (8)**.
- Svejsedyser (9)** skal (pil L) være placeret på **dysemåleren (34)** og (pil R) på støttepladen.
- Spænd sekskantskruerne på enhedsholderen.
- Flyt **dysemåleren (34)** i position. Bemærk vægten på **dysemåleren (34)**.
- Flyt **varmluftblæseren (8)** i svejseposition.
- Løsn **skruerne til justering af drejeledsaksen (25)**.
- Juster **varmluftblæseren (8)** parallelt med **dysemåleren (34)**.
- Spænd **skruerne til justering af drejeledsaksen (25)**.
- Fjern **dysemåleren (34)**, og udfør testsvejsningen.

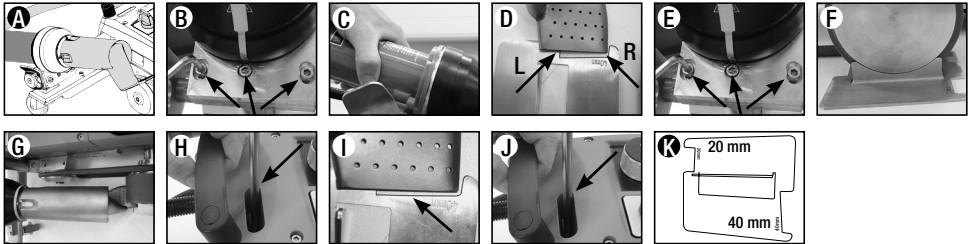

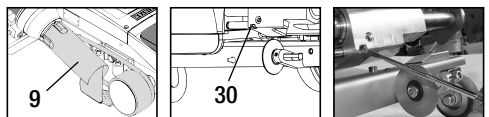

- Manglende opnåelse af den indstillede temperatur (temperaturdisplayet blinker)
 - Tjek netspænding
 - Reducer luftmængden
 - Reducer temperaturen
- Varmluftblæseren låser ikke fast i svejseposition
 - Kugletrykelementet skal indstilles på følgende måde:
 - Lad **svejsedyser (9)** køle af (Side 139, 1. Arbejdstilstand, 1.8 Afkøling)
 - Flyt **svejsedyser (9)** til svejsepositionen
 - Spænd **skruen (30)** en smule med en skruetrækker, drej derefter **skruen (30)** ca. 1/2 omdrejning tilbage.

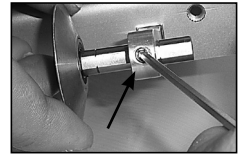
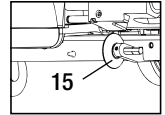
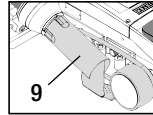

- Svejsesømbredde er ikke konstant
 - Udfør finjustering af styrerullen på følgende måde:
 - Lad **svejsedyesen (9)** køle af (Side 139, 1. Arbejdstilstand, 1.8 Afkøling)
 - Flyt **svejsedyesen (9)** til svejsepositionen
 - Løsn **styrerullens sekskantskrue (15)**
 - Skub **styrerullen (15)** til den ønskede position
 - Spænd sekskantskruen
 - Udfør svejsetest



- Varmluftsvajsemaskinen bevæger sig væk fra svejsningen (overlapsvejsning)
 - Udfør finjustering af **styrerullen (14)** på følgende måde:
 - Lad **svejsedyesen (9)** køle af (side 139, 1. Arbejdstilstand, 1.8 Afkøling)
 - Sluk for **hovedafbryderen (3)** 
 - Tag strømforsyningskablet ud af strømforsyningen 
 - Fjern **ekstra vægt (16)**
 - Vip svejsmaskinen om på siden
 - Løsn **låseskruen til finjustering af skinne (31)** og skub **håndtaget til finjustering af skinne (32)** i den ønskede position
 - Spænd **låseskruen for at finjustere skinnen (31)**
 - Flyt varmluftsvajsemaskinen til svejseposition
 - Indsæt **ekstra vægt (16)**
 - Genstart varmluftsvajsemaskinen
 - Udfør svejsetest

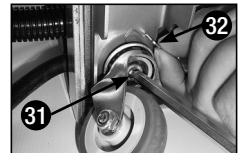
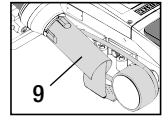
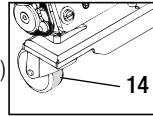

- Opstartsmekanismen virker ikke

Hvis drevmotoren ikke starter automatisk efter isætning af **svejsedyesen (9)**, er **sensoren (6)** muligvis indstillet forkert.



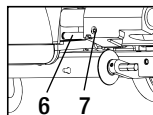
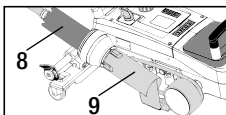

 - Indstil **sensoren (6)** på følgende måde:
 - Lad **svejsedyesen (9)** køle af (side 139, 1. Arbejdstilstand, 1.8 Afkøling)
 - Sluk for **hovedafbryderen (3)** 
 - Brug **varmluftblæseren (8)** til at dreje **svejsedyesen (9)** til svejsepositionen, og lås den fast.
 - Udfør indstilling for **sensoren (6)** ved **indstillingsskruen (7)** med unbraconøgle;

VIGTIGT: Føleafstand 0,2 – 0,5 mm

 - Kontrollér funktion



Hvis drevmotoren stadig ikke starter automatisk, skal servicecenteret kontaktes.

	Overlap	Søm	Kædesting (op til 70 mm)	Rørledning	præfabrikeret rørføring
 <p>Standard udgave</p>	•	•	•		
 <p>Søm-/rør- tilbehør</p>		•	•	•	
 <p>Holdeenhed</p>		•		•	•
 <p>Rørføringsvejledning</p>				•	•

Anvendelse

I stedet for styrerullen (15) kan du også arbejde med kant-/rørtilbehøret.

Også muligt med standardversion og fastgørelse af presenningen.

Også muligt med standardversion og fastgørelse af presenningen.

Det anbefales at bruge en bund med langsgående rille.

Buleri fastgørelse af det præfabrikerede rør.

Type

God fastgørelse af presenningen.

Markering af kantområde for bedre styring.

Markering af kantområde for bedre styring.

Markering af kantområde for bedre styring. Lad enheden køre frit ved manuel styring af presenningen med rørføring.

Leister VARIANT T1-versioner

- Varenr. 141.891 VARIANT T1, 230 V/40 mm svejsedyse/med europæisk stik
- Varenr. 141.892 VARIANT T1, 230 V/20 mm svejsedyse/med europæisk stik
- Varenr. 141.893 VARIANT T1, 400 V/40 mm svejsedyse/med CEE-stik (3LNPE)
- Varenr. 141.894 VARIANT T1, 400 V/20 mm svejsedyse/med CEE-stik (3LNPE)
- Varenr. 147.739 VARIANT T1, 200 V/40 mm svejsedyse/med europæisk stik
- Varenr. 147.748 VARIANT T1, 200 V/20 mm svejsedyse/uden stik

Tilbehør

Af sikkerhedsmæssige og tekniske årsager må der kun anvendes Leister-tilbehør.

- Varenr. 142.650 komplet kant-/rørsæt
- Varenr. 140.530 Kant-/rørtilbehør
- Varenr. 142.221 Holdeenhed
- Varenr. 141.326 Rørføringsvejledning
- Varenr. 139.438 Ekstra vægt
- Varenr. 137.843 T-håndtag til toppen af styrebjælken
- Varenr. 116.798 Messingbørste
- Varenr. 142.705 Bæretaske

Uddannelse

- Leister Technologies AG og dets autoriserede servicecentre tilbyder gratis svejsekurser og træning. Oplysninger på www.leister.com.

Vedligeholdelse

- Luftindgangen på **varmluftblæseren (8)** skal rengøres med en børste, hvis den er snavset.
- Rengør **svejsedysen (9)** med en messingbørste.
- Kontrollér **strømkablet (1)** og stikket for elektriske og mekaniske skader.



Service og reparation

- Hvis tælleren når 400 t, eller blæsertælleren når 2000 t, vises meddelelsen **“Vedligeholdelsesservice”** på **displayet (5)**, næste gang **hovedafbryderen (3)** tændes. Denne meddelelse vises i 10 sekunder og kan ikke springes over med **betjeningselementerne (4)**.
- Reparationer må kun udføres af autoriserede **Leister-servicecentre**. De garanterer en professionel, pålidelig **reparationservice inden for 24 timer** med originale reservedele i henhold til strømskemaerne og listerne over reservedele.

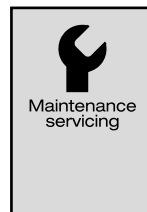

Garanti

- For dette værktøj gælder garanti- eller garantirettigheder, der er tildelt af den relevante distributør/sælger. I tilfælde af garantikrav vil enhver fabrikations- eller håndværksfejl enten blive repareret eller udskiftet af distributøren efter eget skøn. Garanti- eller garantirettigheder skal verificeres af en faktura eller et leveringsdokument. Varmeelementer er ikke inkluderet i garantien.
- Yderligere garantikrav udelukkes med forbehold for præceptive lovbestemmelser.
- Garantien gælder ikke for defekter forårsaget af normal slitage, overbelastning eller forkert håndtering.
- Garanti afvises for værktøj, der er blevet ændret af køberen.



Your authorised Service Centre is:

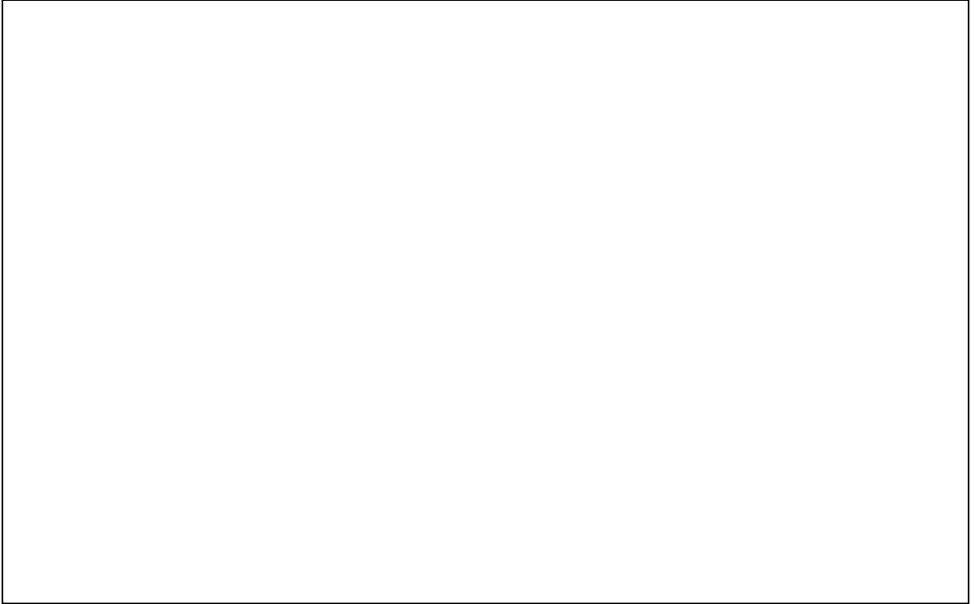

Leister Technologies AG
Galileo-Strasse 10
CH-6056 Kaegiswil/Switzerland
Tel. +41 41 662 74 74
Fax +41 41 662 74 16
www.leister.com
sales@leister.com