

Product Datasheet

OEM Gas Sensing Module LGD Compact-A Series

1 General Description

Axetris is offering Laser Gas Detection (LGD) modules with exceptional advantages and value for the customer. Tunable Diode Laser Spectrometry (TDLS), enhanced by proprietary technology, is used for the measurement of CH₄, CO₂, C₂H₆, C₂H₂, NH₃ and H₂O. The modules are designed for integration by Original Equipment Manufacturers (OEMs), active in the field of gas detection and monitoring in various industries.

The **LGD Compact** series allows the measurement of target gas, based on contactless, near-infrared absorption. The modules come with a flow-through cell set-up for extractive measurements and are self-contained, ready-to-use.

The proprietary lock-in technology as well as the onboard digital signal processing unit runs algorithms compensating drift phenomena and providing reliable and stable measurements over time as well as enhanced detectivity. The OEM modules include an analog and digital data interface as well as digital outputs for state-of-the-art industrial connectivity.

Low maintenance during operation and long life-time provide customers with exceptional low cost-of-ownership and make the LGD Compact series the ideal solution for your OEM gas sensing applications.

Main applications

- **Leak Detection:** portable instruments, static measurement stations, vehicle-mounted, underwater, refrigeration, toxic gases, ...
- **Environmental & Climate Monitoring:** landfill, greenhouse gases, biogas, livestock, underwater research
- **Medical Applications related to Breath Analysis:** gastrointestinal diseases, liver and kidney diseases detection, ...
- **Various Applications:** gas analysis, control and monitoring in various sectors such as industrial, chemical, automotive, semiconductor, agricultural, ...

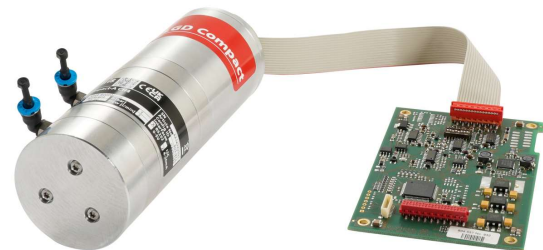

Benefits at a Glance:

- Suited for ambient gas measurement applications
- Optical, laser-based and contactless measurement
- High selectivity and long-term stability
- Fast response time
- Compact and self-contained design permitting quick integration by OEMs
- Digital and analog data interfaces, digital outputs
- Continuous sensor status monitoring
- Power supply 3.7 - 5 VDC and 10 – 30 VDC
- Low power consumption for battery-powered applications
- Low cost-of-ownership

2 Execution Specifications

2.1 Gas detection specifications for LGD Compact-A CH4

Reference conditions (if not otherwise specified): operating temperature 20°C, pressure 1013 hPa and humidity 45% r.H., power supply 10 - 30 VDC

Parameter	Unit	Value / Range		
Principle of measurement	-	Tunable Diode Laser Spectroscopy (TDLS)		
Target gas	-	CH ₄		
Measuring range	ppm	Low Range 0 – 100 (Full Scale)	Mid Range 0 – 2'000 (Full Scale)	High Range 0 – 40'000 (Full Scale)
Lowest Detection Limit ¹ 2σ	ppm	≤ 0.4 ≤ 0.15 with 10 s averaging ²		
Precision ³ 2σ	ppm	≤ 0.8 or 0.6% of Reading, whichever is larger		
Sampling rate	Hz	2		
T ₉₀ time	s	≤ 1.8 at 2 l/min		
Resolution	ppm	0.01		
Accuracy ⁴		± 2 ppm or ± 2% of Reading, whichever is larger		
Linearity and repeatability	-	included in the accuracy		
Cross interference	-	Gas matrix and application dependent		
Temperature limitation	°C	-10 to +50		

¹ **Lowest Detection Limit (LDL):** The LDL is defined as 2 times the standard deviation σ evaluated over a time period of a 2 min measurement at stable reference conditions with set point 0 ppm. The LDL of the system can be improved by mean of averaging.

² **Averaging time:** An exponential moving average (EMA) is applied on measured concentration values. The averaging time expresses the period of time of past measurements considered to compute the next averaged value. The averaging time can be set up to 600 s.

³ **Precision:** The precision is defined as 2 times the standard deviation σ of a 2 min measurement at stable reference conditions over the full measuring range. The precision of the system can be improved by mean of averaging.

⁴ **Accuracy:** The accuracy is defined as the difference between the mean response during a 2 min time interval and the reference value at reference conditions. Variations of the operating temperature and pressure can affect the accuracy of the system.

2.2 Gas detection specifications for LGD Compact-A CH4/C2H6

Reference conditions (if not otherwise specified): operating temperature 20°C, pressure 1013 hPa and humidity 45% r.H., power supply 10 - 30 VDC

Parameter	Unit	Value / Range		
Principle of measurement	-	Tunable Diode Laser Spectroscopy (TDLS)		
Target gas	-	CH ₄		C ₂ H ₆
Measuring range	ppm	0 – 100 (Full Scale)	0 – 40'000 (Full Scale)	0 – 1'000* (Full Scale)
Lowest Detection Limit ⁵ 2σ	ppm	≤ 0.8 ≤ 0.25 with 10 s averaging ⁶ ≤ 0.1 for version Plus		≤ 15 or 10 / % CH ₄ , whichever is larger
Precision ⁷ 2σ	ppm	≤ 1.5 ≤ 0.5 with 10 s averaging	≤ 250 ≤ 100 with 10 s averaging	≤ 20 or 10 / % CH ₄ , whichever is larger
Sampling rate dual gas mode	Hz	0.7		
Sampling rate single gas mode	Hz	2		-
T ₉₀ time	s	≤ 1.8 at 2 l/min		≤ 15 at 2 l/min
Resolution	ppm	0.01		
Accuracy ⁸	% of FS	± 3		≤ 2 or 4 / % CH ₄ , whichever is larger
Linearity and repeatability	-	included in the accuracy		
Cross interference	-	Gas matrix and application dependent		
Temperature limitation	°C	0 to 40		

* Examples for C₂H₆ detection in CH₄ gas matrix

C ₂ H ₆	CH ₄	Ratio ⁹	Measurement Result
50 ppm	10'000 ppm	1:200	C ₂ H ₆ detectable
50 ppm	5'000 ppm	1:100	C ₂ H ₆ detectable
50 ppm	20'000 ppm	1:400	C₂H₆ not detectable
1000 ppm	10'000 ppm	1:10	C ₂ H ₆ detectable

⁵ **Lowest Detection Limit (LDL):** The LDL is defined as 2 times the standard deviation σ evaluated over a time period of a 2 min measurement at stable reference conditions with set point 0 ppm. The LDL of the system can be improved by mean of averaging.

⁶ **Averaging time:** An exponential moving average (EMA) is applied on measured concentration values. The averaging time expresses the period of time of past measurements considered to compute the next averaged value. The averaging time can be set up to 600 s.

⁷ **Precision:** The precision is defined as 2 times the standard deviation σ of a 2 min measurement at stable reference conditions over the full measuring range. The precision of the system can be improved by mean of averaging.

⁸ **Accuracy:** The accuracy is defined as the difference between the mean response during a 2 min time interval and the reference value at reference conditions. Variations of the operating temperature and pressure can affect the accuracy of the system.

⁹ **C₂H₆/CH₄ Ratio:** C₂H₆ is just detectable in a CH₄ gas matrix in the ratios from 1:200 up to 1:10 at reference conditions. Variations of operating temperature and pressure can affect the C₂H₆ detectivity.

2.3 Gas detection specifications for LGD Compact-A CH₄/CO₂

Reference conditions (if not otherwise specified): operating temperature 20°C, pressure 1013 hPa and humidity 45% r.H., power supply 10 - 30 VDC

Parameter	Unit	Value / Range	
Principle of measurement	-	Tunable Diode Laser Spectroscopy (TDLS)	
Target gas	-	CH ₄	CO ₂
Measuring range	ppm	0 – 100 (Full Scale) linear up to 250 ppm	0 – 100'000 (Full Scale)
Lowest Detection Limit ¹⁰ 2σ	ppm	≤ 0.4 ≤ 0.15 with 10 s averaging ¹¹	≤ 2'000 ≤ 600 with 10 s averaging
Precision ¹² 2σ	ppm	≤ 0.8 ≤ 0.25 with 10 s averaging	≤ 2000 ≤ 600 with 10 s averaging
Sampling rate	Hz	0.7	
T ₉₀ time	s	≤ 30 at 0.3 l/min	
Resolution	ppm	0.01	
Accuracy ¹³	% of FS	± 2	± 3
Linearity and repeatability	-	included in the accuracy	
Cross interference	-	Gas matrix and application dependent	
Temperature limitation	°C	10 to 40	

¹⁰ **Lowest Detection Limit (LDL):** The LDL is defined as 2 times the standard deviation σ evaluated over a time period of a 2 min measurement at stable reference conditions with set point 0 ppm. The LDL of the system can be improved by mean of averaging.

¹¹ **Averaging time:** An exponential moving average (EMA) is applied on measured concentration values. The averaging time expresses the period of time of past measurements considered to compute the next averaged value. The averaging time can be set up to 600 s.

¹² **Precision:** The precision is defined as 2 times the standard deviation σ of a 2 min measurement at stable reference conditions over the full measuring range. The precision of the system can be improved by mean of averaging.

¹³ **Accuracy:** The accuracy is defined as the difference between the mean response during a 2 min time interval and the reference value at reference conditions. Variations of the operating temperature and pressure can affect the accuracy of the system.

2.4 Gas detection specifications for LGD Compact-A NH₃/H₂O

Reference conditions (if not otherwise specified): operating temperature 45°C, pressure 1013 hPa and humidity 20% r.H., power supply 10 - 30 VDC

Parameter	Unit	Value / Range	
Principle of measurement	-	Tunable Diode Laser Spectroscopy (TDLS)	
Target gas	-	NH ₃	H ₂ O
Measuring range	ppm	0 – 100 (Full Scale)	0 – 50'000 ¹⁴ (Full Scale)
Lowest Detection Limit ¹⁵ 2σ	ppm	≤ 0.4 ≤ 0.15 with 10 s averaging ¹⁶	≤ 1'500 ≤ 400 with 10 s averaging
Precision ¹⁷ 2σ	ppm	≤ 0.8 ≤ 0.25 with 10 s averaging	≤ 2'000 ≤ 500 with 10 s averaging
Sampling rate	Hz	0.7	
T ₉₀ time	s	≤ 3 at 2 l/min	
Resolution	ppm	0.01	
Accuracy ¹⁸	ppm	± 2	± 4000
Linearity and repeatability	-	included in the accuracy	
Cross interference	-	Gas matrix and application dependent	
Temperature limitation	°C	0 to +55	

¹⁴ **H₂O Range:** depending on operating temperature, non-condensing conditions required in any case.

¹⁵ **Lowest Detection Limit (LDL):** The LDL is defined as 2 times the standard deviation σ evaluated over a time period of a 2 min measurement at stable reference conditions with set point 0 ppm. The LDL of the system can be improved by mean of averaging.

¹⁶ **Averaging time:** An exponential moving average (EMA) is applied on measured concentration values. The averaging time expresses the period of time of past measurements considered to compute the next averaged value. The averaging time can be set up to 600 s.

¹⁷ **Precision:** The precision is defined as 2 times the standard deviation σ of a 2 min measurement at stable reference conditions over the full measuring range. The precision of the system can be improved by mean of averaging.

¹⁸ **Accuracy:** The accuracy is defined as the difference between the mean response during a 2 min time interval and the reference value at reference conditions. Variations of the operating temperature and pressure can affect the accuracy of the system.

2.5 Gas detection specifications for LGD Compact-A C2H2/H2O

Reference conditions (if not otherwise specified): operating temperature 45°C, pressure 1013 hPa and humidity 20% r.H., power supply 10 - 30 VDC

Parameter	Unit	Value / Range	
Principle of measurement	-	Tunable Diode Laser Spectroscopy (TDLS)	
Target gas	-	C ₂ H ₂	H ₂ O
Measuring range	ppm	0 – 100 (Full Scale) linear up to 500 ppm	0 – 100'000 ¹⁹ (Full Scale)
Lowest Detection Limit ²⁰ 2σ	ppm	≤ 0.6 ≤ 0.20 with 10 s averaging ²¹	≤ 1'000 ≤ 500 with 10 s averaging
Precision ²² 2σ	ppm	≤ 0.8 ≤ 0.25 with 10 s averaging	≤ 1'000 ≤ 500 with 10 s averaging
Sampling rate	Hz	0.7	
T ₉₀ time	s	≤ 60 at 0.6 l/min	
Resolution	ppm	0.01	
Accuracy ²³	% of FS	± 2	± 1.5
Linearity and repeatability	-	included in the accuracy	
Cross interference	-	Gas matrix and application dependent	
Temperature limitation	°C	15 to 55	

¹⁹ **H₂O Range:** depending on operating temperature, non-condensing conditions required in any case.

²⁰ **Lowest Detection Limit (LDL):** The LDL is defined as 2 times the standard deviation σ evaluated over a time period of a 2 min measurement at stable reference conditions with set point 0 ppm. The LDL of the system can be improved by mean of averaging.

²¹ **Averaging time:** An exponential moving average (EMA) is applied on measured concentration values. The averaging time expresses the period of time of past measurements considered to compute the next averaged value. The averaging time can be set up to 600 s.

²² **Precision:** The precision is defined as 2 times the standard deviation σ of a 2 min measurement at stable reference conditions over the full measuring range. The precision of the system can be improved by mean of averaging.

²³ **Accuracy:** The accuracy is defined as the difference between the mean response during a 2 min time interval and the reference value at reference conditions. Variations of the operating temperature and pressure can affect the accuracy of the system.

3 General Specifications

3.1 Environmental conditions

Parameter	Unit	Value / Range
Usage	-	Interior use
Operating temperature range	°C	-10 ... +65 ²⁴
Operating humidity	% r.H.	0 ... 99, non-condensing
Operating pressure	mbar	800 ... 1100
Storage temperature	°C	-40 ... +80
Storage humidity	% r.H.	0 ... 99, non-condensing

3.2 Mechanical characteristics

Parameter	Unit	Value / Range
Measurement cell	-	Flow-through set-up
Cell volume	ml	19
Gas flow (min - max)	ml / min	100 - 3'000
Dimensions of sensor module	mm	Generation 1: 163 (length) 50 (diameter w/o fittings and electrical connector) Generation 2: Basic: 146 (length) // 50 (diameter) EMC Conform: 163 (length) // 50 (diameter)
Approx. weight sensor module	g	Generation 1: ≤ 600 Generation 2: Basic: 510 EMC Conform: 630
Dimensions of electronic unit with housing	mm	Generation 1: 257 x 83 x 26 (L x W x H) Generation 2: 163 x 78 x 43 (L x W x H)
Dimensions of electronic board without housing (optional)	mm	105 x 70 x 11 (L x W x H, main board) 84 x 70 x 11 (L x W x H, interface board)

²⁴ For application specific temperature ranges please see the specifications in chapter 2

3.3 Electrical characteristics

Parameter	Unit	Value / Range
Voltage supply with interface board; min. - max.	VDC	10 - 30 (max. ripple \pm 100mV, max. current 1A, inrush current limitation)
Voltage supply without interface board; min. - max.	VDC	3.7 – 5 (no inrush current limitation) Note: Limitations related to data interface to be considered, refer to section 3.4
Power consumption	W	\leq 1 at T _{amb} 20°C (Up to 3 W in extreme conditions)
Start-up time	s	\leq 30

3.4 Data interface

Module powered at 10 - 30 VDC (with interface board)

Parameter	Unit	Value / Range
RS 232 EIA	-	RS232 protocol
Analog Current Output	mA	4 - 20, 12-bit resolution
Analog Voltage Output	V	0 - 5, 12-bit resolution
Resistive loads		
for voltage output	k Ω	> 2
for current output	k Ω	< 0.47
Capacitive loads		
For voltage output	pF	< 200
For current output	pF	< 200
Digital Alarm Outputs (relay)	-	Relay power supply: 10 V < V _{cc} Relay < 30 V; max. 0.75 A Various alarm outputs available, for more details refer to the Operation and Integration Instructions.
Protection		ESD protected

Module powered at 3.7 – 5 VDC (without interface board)

Parameter	Unit	Value / Range
RS 232 TTL	-	RS232 protocol, TTL signal amplitude 0 - 3.3 VDC
Analog Voltage Output	V	0 - 2.5, 12-bit resolution
Resistive loads	k Ω	> 5
Capacitive loads	pF	< 100
Digital Alarm Outputs	-	TTL signal amplitude 0 – 3.3 VDC Note: contact Axetris if needed
Protection		No protection implemented

4 Configuration Options

4.1 Generation 1

EMC conform product execution





	<p>LGD Compact Sensor module with main- and interface board in a box and a shielded cable</p> <p>Available cables:</p> <p>M12 straight D sub 200 mm shielded (Phoenix Contact 1430200)</p> <p>M12 angled D sub 200 mm shielded (Phoenix Contact 1430242)</p>
---	--

Basic product executions

	<p>LGD Compact Sensor module with main- and interface board and an unshielded cable</p> <p>Available cables:</p> <p>M12 straight D sub 200 mm unshielded (Phoenix Contact 1430695)</p> <p>M12 angled D sub 200 mm unshielded (Phoenix Contact 1430734)</p>
--	--

	<p>LGD Compact Sensor module with mainboard and an unshielded cable</p> <p>Available cables:</p> <p>M12 straight D sub 200 mm unshielded (Phoenix Contact 1430695)</p> <p>M12 angled D sub 200 mm unshielded (Phoenix Contact 1430734)</p>
---	--

Cable and gas fitting connectors

Cable Connectors		Gas Fittings	
			
<p>Phoenix Contact (M12 straight D sub 200 mm)</p>	<p>Phoenix Contact (M12 angled D sub 200 mm)</p>	<p>Festo (QSM-M5-4, straight)</p>	<p>Festo (QSML-M5-4, angled)</p>

Phoenix Contact (M12 angled D sub)

The angled plug can be oriented in any direction.
The orientation must be specified when ordering.

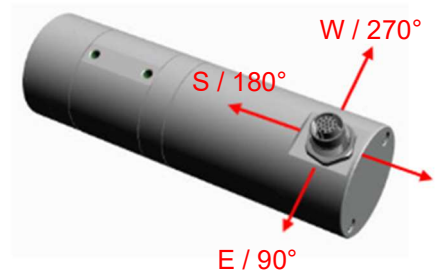

4.2 Generation 2

EMC conform product execution

	<p>LGD Compact Sensor module with main- and interface board in a box and a shielded cable. The cable is not detachable from the sensing module.</p>
	<p>LGD Compact Sensor module with main- and interface board in a box (long version) and a shielded cable. The cable is not detachable from the sensing module.</p>

Basic product executions

	<p>LGD Compact Sensor module with main- and interface board and an unshielded cable</p> <p>Available cable: Flat ribbon 16p, 28AWG (JST, JFCR28L-16G127), 200mm with MicroMatch 16 pol connector (Cvilux, CA3016P1310)</p>
	<p>LGD Compact Sensor module with mainboard and an unshielded cable</p> <p>Available cable: Flat ribbon 16p, 28AWG (JST, JFCR28L-16G127), 200mm with MicroMatch 16 pol connector (Cvilux, CA3016P1310)</p>

5 Connector Assignments

5.1 Product execution with electronics housing

Figure 1: 15pol D-Sub connector (J1)

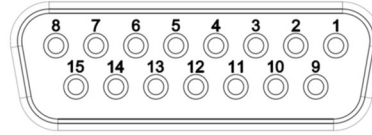

Connector assignment J1

	Pin	Name	Description
Power Supply	1	POWER IN	Power supply 10 ... 30V
	2	GND IN*	Power supply ground
	3	SHIELD	DB 15 Connector - Housing
Digital Interface	6	GND*	Ground serial communication
	7	RS232 TX	UART serial communication
	8	RS232 RX	UART serial communication
	14	N/A	Not used
	15	N/A	Not used
Digital Alarms (relay)	4	ALARM 1	On/Off signal at defined conditions for relay control, hardware watchdog, etc.
	5	ALARM 2	On/Off signal at defined conditions for relay control, hardware watchdog, etc.
	11	ALARM 3	HW watchdog, firmware error and warnings
	12	VCC RELAY	Relay power supply: 10 V < Vcc Relay < 30 V; max. 0.75 A
	13	GND*	Ground, relay alarms
Analog Interface	9	ANALOG GND*	Analog ground
	10	ANALOG OUT	Analog output Factory setting: current output (4-20mA); voltage output (0-5V) configurable

* same potential

5.2 Product executions without electronics housing

Figure 2: Top view main board with connector J5 and J6

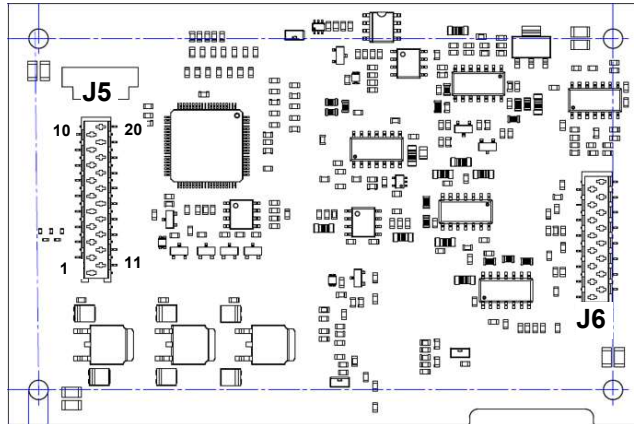

Connector assignment J5

	Pin	Name	Description
Power Supply	1	5V*	Power supply input for mainboard (3.7 – 5V)
	2	5V*	Power supply input for mainboard (3.7 – 5V)
	3	3.3V	Power supply output 3.3V from mainboard to drive digital hardware on interface board; not used in case of removing the interface board
Digital Interfaces	4	TXD TTL	UART serial communication TTL-Level
	5	RXD TTL	UART serial communication TTL-Level
Digital Alarms	13	ALARM 1	Signal for alarm 1 from Microcontroller, contact Axetris if needed
	15	ALARM 2	Signal for alarm 2 from Microcontroller, contact Axetris if needed
Analog Interface	10	DAC ANALOGOUT	Analog output signal (0...2.5V) from Microcontroller, contact Axetris if needed
	16	HW INTERFACE PCB	Input for identification of interface board, connect to GND in case of removing the interface board
	11	GND**	Ground
	12	GND**	Ground
Not used	6...9	n/a	n/a
	14,	n/a	n/a
	17...20		

* connected on mainboard

** same potential

Figure 3: Top view interface board with connector J3.

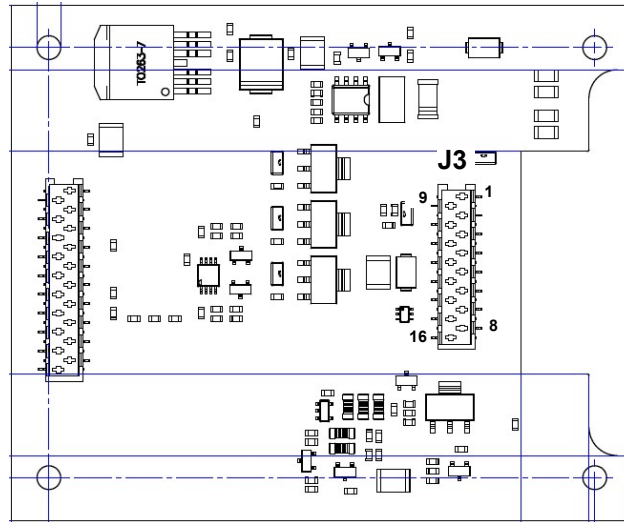

Connector assignment J3

The connector assignment of J3 is identical to J1 (refer to section 5.1) except the additional pin 16 which is not used.

	Pin	Name	Description
Not used	16	n/a	n/a

6 Product Dimensions

6.1 Generation 1

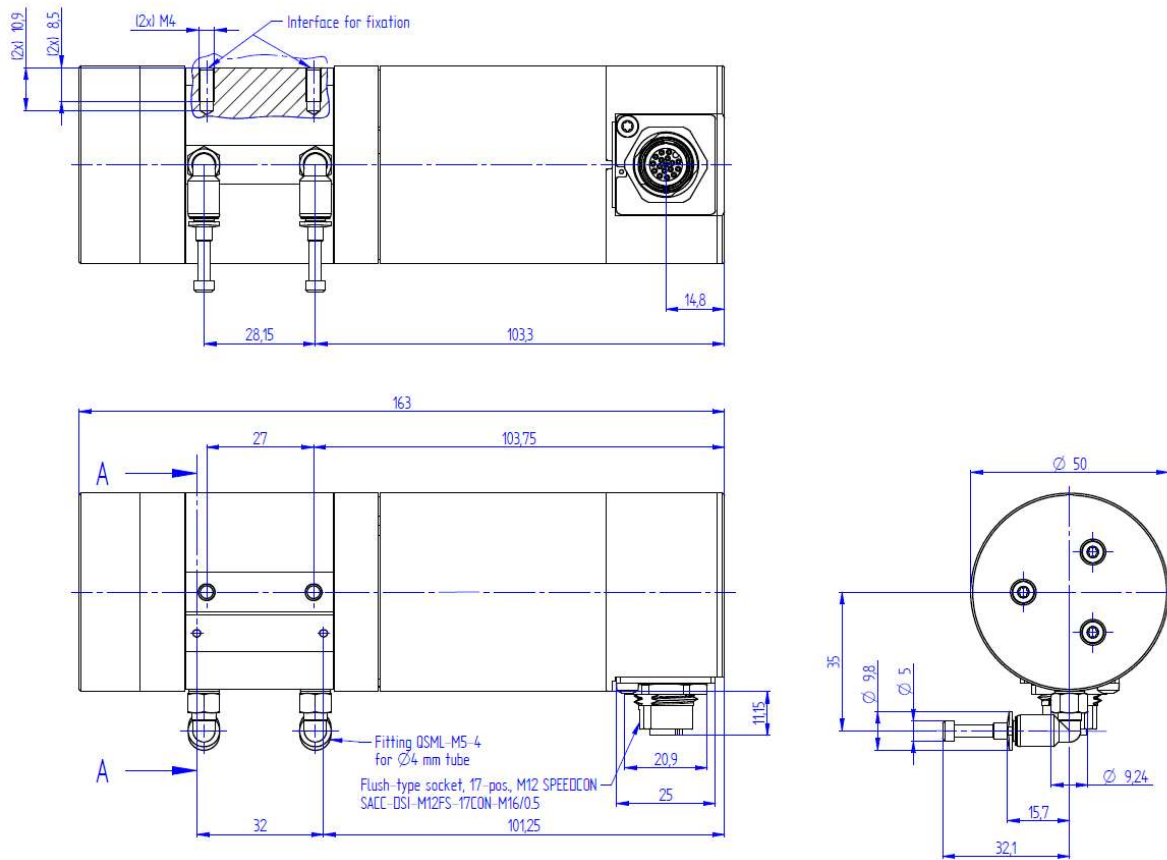

Figure 4: Side and front view, with gas connectors. Dimensions in mm

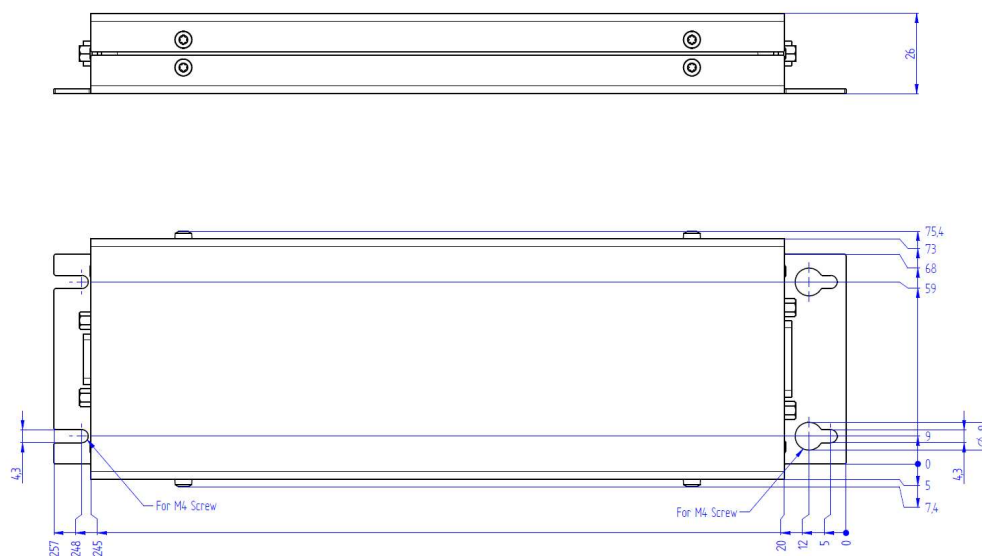

Figure 5: View of the electronics housing. Dimensions in mm

6.2 Generation 2

EMC conform product execution

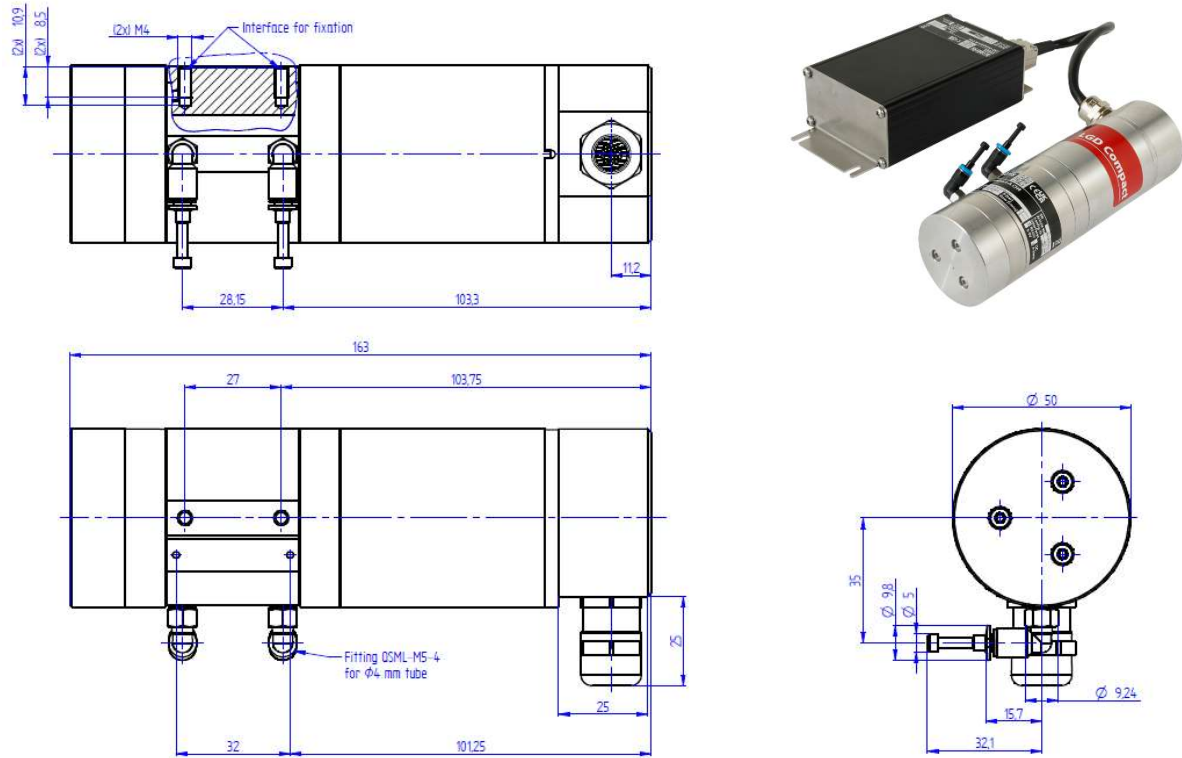

Figure 6 Dimensions from EMC Conform sensing module Generation 2

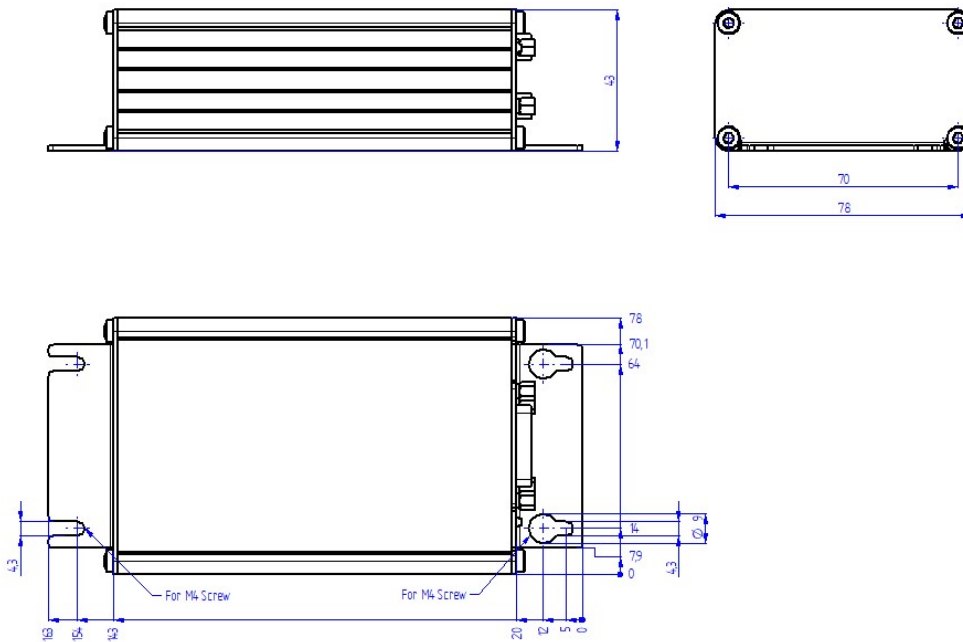

Figure 7 Dimensions from EMC Conform electronic box Generation 2

Basic product executions

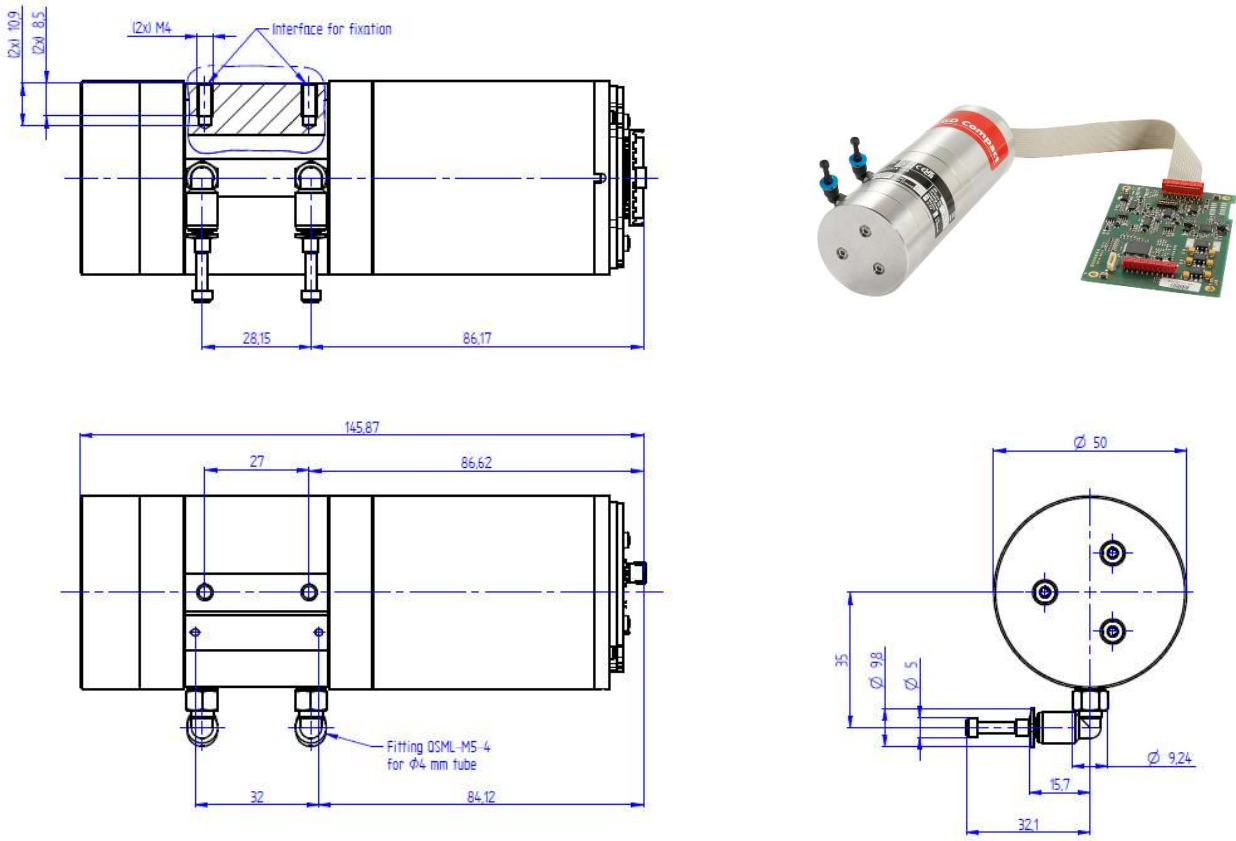

Figure 8 Dimensions from Basic execution sensing module Generation 2

6.3 Electronic boards (common to all generations)

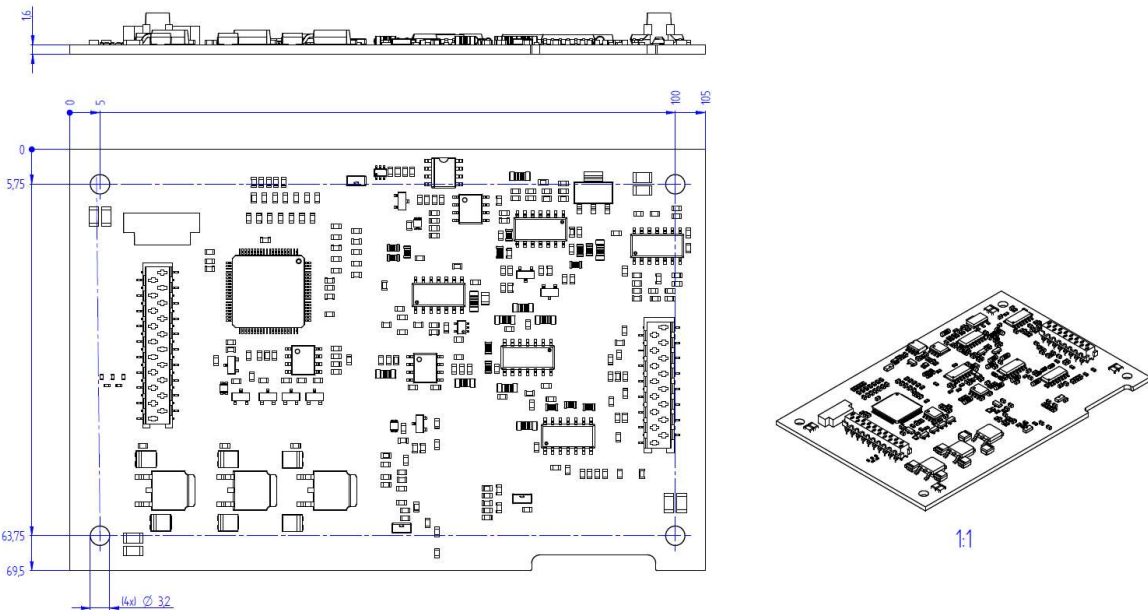

Figure 9: Main printed circuit board. Dimensions in mm

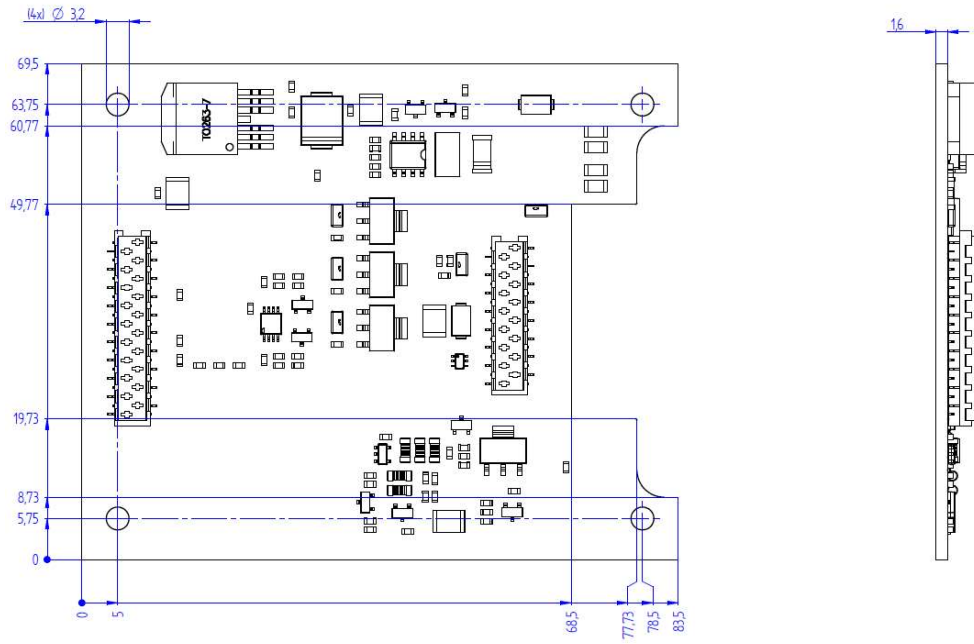

Figure 10: View of the interface printed circuit board. Dimensions in mm

7 Norms and Regulations

Important: conformity to the standards specified here only applies for product executions delivered with electronics housing and shielded cables specified in section 4.

Type	Standard / Directive	Limits / description
LGD Compact Platform conformity	REACH, CE	
Electronics conformity	RoHS, WEEE	
EMC	EN/IEC 61326-1 EN/IEC 61000-6-2 EN/IEC 61000-6-3 ²⁵	Conformity granted only for product executions delivered with electronics housing. For product executions without electronics housing, the EMC conformity has to be fulfilled by the integrating Original Equipment Manufacturer itself.
Shock	EN60068-2-27	max acceleration 150 m/s ² , 11 ms, half sinus, 18 cycles
Vibration	EN60068-2-6	5 - 55 Hz, amplitude 0.35 mm, 1 octave/min, 2h 20 min per orientation (20 frequency cycles)
Drop Test	EN 22248	Free fall with packaging

²⁵ LGD Compact-A Generation 2 EMC Conform execution: norm EN/IEC 61000-6-4 is tested and achieved

8 Caution

8.1 Product damage

- Read all instructions carefully before using the device.
- The LGD Compact laser gas detection modules are calibrated for a particular gas and concentration range. Do not use the device outside of its specifications.
- The device is not suited for measuring gases with a dust load. The incoming measurement gas must be conditioned in order to avoid dust and condensation of liquid in the measurement cell. Gas loaded with particles or other substances can eventually contaminate the measurement cell and make it necessary to service the instrument.
- The appliance must not be used in damp or wet surroundings.
- Use only accessories that are indicated in the instructions for use or are recommended by the manufacturer.
- Failure to comply with these instructions could result in product damage.

8.2 Danger of life

- The device must not be used with flammable or explosive gases or mixtures.
- Unprofessional gas handling can cause injury or death. The use of gas detection modules should only be performed by qualified personnel

- Do not use this product as safety or emergency stop device or in any other application where failure of the product could result in personal injury or death.

9 Important Notice / Disclaimer

The information furnished by Axetris is believed to be correct and accurate. However, Axetris shall not be held liable to recipient or any third party of any damages, including but not limited to personal injury, property damage, loss of profits, loss of use, interrupt of business or indirect, special incidental or consequential damages, of any kind, in connection with or arising out of the furnishing, performance or use of technical data herein. No obligation or liability to recipient or any third party shall arise or flow out of Axetris rendering of technical or other services.

While due caution has been exercised in the production of this document, possible errors and omissions are unintentional.

10 Axetris Certifications

Axetris is an ISO 9001:2015 certified company. The LGD Compact module is CE and RoHS compliant (only be granted for product executions delivered with electronics housing and shielded cables specified in section 4).

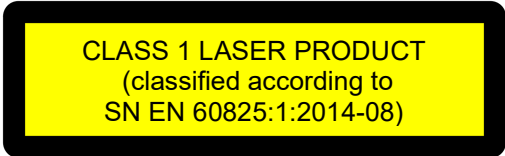

© 2020 AXETRIS AG – Company of the Leister Group

Contact

Headquarters:
Axetris AG, Switzerland
Schwarzenbergstrasse 10
CH-6056 Kaegiswil
Switzerland
phone: +41 41 662 76 76
fax: +41 41 662 75 25
axetris@axetris.com
www.axetris.com

USA:
Leister Technologies LLC
1275 Hamilton Parkway
Itasca, IL 60143
United States
phone: +1 630 760 1000
fax: +1 630 760 1001
axetris.usa@axetris.com
www.axetris.com

China:
Leister Technologies Ltd.
Building 11, 155 Yuanke Road
Shanghai 201109 PR China
Xinzhuan Industry Park
phone: +86 21 6442 2398
fax: +86 21 6442 2338
axetris@axetris.cn
www.axetris.cn

Japan:
Leister Technologies KK
Shinyokohama Bousei Bldg
1F
3-20-12, Shinyokohama,
Kohoku-ku
Yokohama 222-0033 / Japan
phone: +81 45 477 36 37
fax: +81 45 477 36 38
axetris@axetris.jp
www.axetris.jp

Swiss Made Quality. Axetris is an **ISO 9001** certified enterprise. Specifications are subject to change without prior notice